

USER MANUAL
INTELLIGENT ADAS IA900WA
(AUTEL-CSC9000)



Trademarks

Autel® and MaxiSys® are trademarks of Autel Intelligent Technology Corp., Ltd., registered in China, the United States, and other countries. All other marks are trademarks or registered trademarks of their respective holders.

Copyright Information

No part of this manual may be reproduced, stored in a retrieval system or transmitted in any form or by any means electronic, mechanical, photocopying, recording, or otherwise without the prior written permission of Autel.

Disclaimer of Warranties and Limitation of Liabilities

All information, specifications and illustrations in this manual are based on the latest information available at the time of printing.

Autel reserves the right to make changes at any time without notice. While information of this manual has been carefully checked for accuracy, no guarantee is given for the completeness and correctness of the contents, including but not limited to the specifications, functions, and illustrations.

Autel will not be liable for any direct, special, incidental, or indirect damages, or for any economic consequential damages (including the loss of profits) as a result of using this equipment.

IMPORTANT

Before operating or maintaining this equipment, please read this manual carefully, paying extra attention to the safety warnings and precautions.

For Services and Support



pro.autel.com

www.autel.com



1-855-288-3587 (North America)

+86 (0755) 8614-7779 (China)



support@autel.com

For technical assistance in all other markets, please refer to *Technical Support* in this manual.

Safety Information

For your own safety and the safety of others, and to prevent damage to the equipment and vehicles upon which it is used, it is important that the safety instructions presented throughout this manual be read and understood by all persons operating or coming into contact with the equipment.

There are numerous procedures, techniques, tools, and parts required for servicing vehicles, as well as the skills of the person doing the work. Because of the vast number of test applications and variations in the products that can be tested with this equipment, we cannot possibly anticipate or provide advice or safety messages to cover every circumstance. It is the automotive technician's responsibility to be knowledgeable of the system being tested. It is crucial to use proper service methods and test procedures. It is essential to perform tests in an appropriate and acceptable manner that does not endanger your safety, the safety of others in the work area, the device being used, or the vehicle being tested.

Before using the equipment, always refer to and follow the safety messages and applicable test procedures provided by the manufacturer of the vehicle or equipment being tested. Use the equipment only as described in this manual. Be sure to read, understand, and follow all safety messages and instructions in this manual.

Safety Messages

Safety messages are provided to help prevent personal injury and equipment damage. All safety messages are introduced by a signal word indicating the hazard level.

DANGER

Indicates an imminently hazardous situation which, if not avoided, could result in death or serious injury to the operator or to bystanders.

WARNING

Indicates a potentially hazardous situation which, if not avoided, could result in death or serious injury to the operator or to bystanders.

Safety Instructions

The safety messages herein cover situations Autel is aware of at the time of publication. Autel cannot know, evaluate or advise you as to all of the possible hazards. You must be certain that any condition or service procedure encountered does not jeopardize your personal safety.

 **DANGER**

When an engine is operating, keep the service area WELL VENTILATED or attach a building exhaust removal system to the engine exhaust system. Engines produce carbon monoxide, an odorless, poisonous gas that causes slower reaction time and can lead to serious personal injury or loss of life.

 **It is not advised to use headphones at a high volume**

Listening at high volumes for long periods of time may result in loss of hearing.

 **Safety Warnings**

- Always perform automotive testing in a safe environment.
- Wear safety eye protection that meets ANSI standards.
- Keep clothing, hair, hands, tools, test equipment, etc. away from all moving or hot engine parts.
- Operate the vehicle in a well-ventilated work area, for exhaust gases are poisonous.
- Put the transmission in PARK (for automatic transmission) or NEUTRAL (for manual transmission) and make sure the parking brake is engaged.
- Put blocks in front of the drive wheels and never leave the vehicle unattended while testing.
- Be extra cautious when working around the ignition coil, distributor cap, ignition wires and spark plugs. These components create hazardous voltages when the engine is running.
- Keep a fire extinguisher suitable for gasoline, chemical, and electrical fires nearby.
- Do not connect or disconnect any test equipment while the ignition is on or the engine is running.
- Keep the test equipment dry, clean, free from oil, water or grease. Use a mild detergent on a clean cloth to clean the outside of the equipment as necessary.
- Do not drive the vehicle and operate the test equipment at the same time. Any distraction may cause an accident.
- Refer to the service manual for the vehicle being serviced and adhere to all diagnostic procedures and precautions. Failure to do so may result in personal injury or damage to the test equipment.
- To avoid damaging the test equipment or generating false data, make sure the vehicle battery is fully charged and the connection to the vehicle's DLC is clean and secure.
- Do not place the test equipment on the distributor of the vehicle. Strong electromagnetic interference can damage the equipment.

LASER RADIATION



Never point the laser beam at people, particularly at their face or eyes.

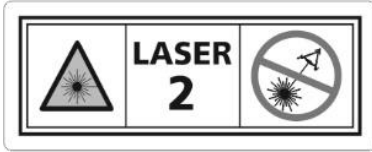

The term laser equipment refers to devices, systems or test set-ups generating, transmitting or employing laser radiation.

The class of the laser device indicates the level of potential danger associated with its accessible laser radiation. In the case of class 2 laser equipment, the accessible laser radiation is in the visible spectral range (400 nm to 700 nm).

The eyelids provide sufficient protection for inadvertent brief eye contact with such laser radiation. Class 2 laser devices may therefore be used without further precautionary measures if the user is definitely not required to either look into the laser intentionally for extended periods of time (>0.25 s) or repeatedly look into the laser or at directly reflected laser radiation.

WARNING

Taking medication or alcohol consumption will slow down the reflex action of the eyelids. This results in a particular risk. Wearing laser safety glasses of protection level R1 is recommended for anyone who is under the influence of medication.

Persons who are not trained to work with laser equipment and on the hazards of laser radiation, may not enter workplaces where work takes place with laser beams nor a laser emitting device.

Safety measures:

- The operator is to place the warning “Warning of Laser beam” at eye level and in a visible manner at the measuring station.
- Do not look directly into laser source.
- The operator must comply with the intended use.

INFRARED RADIATION



Infrared device inside. Avoid direct eye exposure.

Hot surface. Avoid contact directly.

Safety measures:

- The operator is to place the warning “Warning of Infrared Radiation” at eye level and in a visible manner at the measuring station.
- Do not look directly into IR source.
- The operator must comply with the intended use of the product.

WEAR SAFETY SHOES



Safety shoes must be worn.

When performing work with risk of injury to the feet, notice about the necessity of wearing protective shoes must be given. Foot injuries can, for example, be caused by falling over or falling tools or work items, trapping the foot, occurrence of nails or metal shavings in the soles, etc.

Safety measures:

- The operator is to place the mandatory sign “Wear Safety Shoes” at eye level and in a clearly visible manner at the measuring station.
- Operators should always wear the recommended protective shoes.

CONTENTS

1	USING THIS MANUAL	1
1.1	CONVENTIONS	1
1.1.1	Bold Text	1
1.1.2	Notes and Important Messages.....	1
1.1.3	Hyperlinks.....	2
1.1.4	Illustrations	2
1.1.5	Procedures	2
2	GENERAL INTRODUCTION	3
2.1	SAFETY INSTRUCTIONS AND PRECAUTIONS	3
2.2	PRODUCT DESCRIPTION.....	3
2.2.1	Calibration Frame	3
3	ACCESSORIES INTRODUCTION	12
3.1	STANDARD ACCESSORIES	12
3.2	OTHER NEEDED ACCESSORIES (NOT EQUIPPED)	20
3.2.1	For Wheel Alignment and ADAS Calibration	20
3.2.2	For ADAS Calibration	26
4	WHEEL ALIGNMENT FUNCTION	46
4.1	TECHNICAL SPECIFICATIONS.....	46
4.2	PRECAUTIONS IN USE	47
4.3	FUNCTION SCREENS AND BUTTONS	47
4.3.1	Function Screens.....	47
4.3.2	Function Buttons.....	48
4.4	BEFORE WHEEL ALIGNMENT	49
4.4.1	Preparatory Work	49
4.4.2	Vehicle Communication and Selection	50
4.5	WHEEL ALIGNMENT PROCEDURES	56
4.5.1	Vehicle Inspection	56

4.5.2	Preparation Work.....	63
4.5.3	Compensation	72
4.5.4	Caster/SAI/IA Angle Measurement.....	78
4.5.5	Measured Result	80
4.5.6	Alignment Guide	86
4.5.7	Post-alignment Diagnosis.....	92
4.5.8	ADAS Calibration.....	94
4.5.9	Overhaul Report	94
4.5.10	Save Report and Report Cloud Sharing	97
4.6	GLOSSARY	102
4.6.1	Geometry Centerline.....	102
4.6.2	Thrust Angle	102
4.6.3	Toe	103
4.6.4	Total Toe	104
4.6.5	Camber.....	104
4.6.6	Front Caster.....	105
4.6.7	Steering Axis Inclination (SAI)	106
4.6.8	Included Angle (IA)	106
4.6.9	Toe-out on Turns	107
4.6.10	Maximum Steering Angle.....	108
4.6.11	Ride Height.....	109
4.6.12	Setback Angle	110
4.6.13	Wheel Straight Ahead.....	110
4.6.14	Symmetrical Value.....	110
4.6.15	Rolling Diameter	111
4.7	PERFORM DIAGNOSTIC FUNCTION & ADAS CALIBRATION	111
4.7.1	Before Wheel Alignment.....	111
4.7.2	After Wheel Alignment.....	111

5	ALIGNER & ADAS SETTINGS	112
5.1	COMMON SETTINGS	112
5.1.1	Unit Settings	112
5.1.2	Select Clamp Type	113
5.1.3	Connect Tread Measuring Tool	114
5.1.4	Select Height Measuring Tool	114
5.1.5	Benz Chassis Level Measuring Tool	115
5.1.6	Beep Setting	115
5.2	CALIBRATION FRAME CONNECTION	116
5.3	NETWORK CONFIGURATION	116
5.4	UPDATE	116
5.5	MAINTENANCE & SERVICE	117
5.5.1	Inclination Sensor Calibration	118
5.5.2	Aligner Calibration	120
5.5.3	Wheel Clamp Target Calibration	124
5.5.4	Accuracy Check	133
5.5.5	Calibration Record Report	146
5.5.6	Accuracy Check Interval	146
5.5.7	Target Cleaning Interval	146
5.6	WHEEL ALIGNMENT SOFTWARE SETTINGS	147
5.6.1	Vehicle Inspection	148
5.6.2	Measurement Preparation	149
5.6.3	Measurement Results	149
5.6.4	Customized Specifications Management	152
5.6.5	Restore Default Settings	152
6	ADAS CALIBRATION FUNCTION	154
6.1	PREPARATORY WORK	154
6.2	ADAPTIVE CRUISE CONTROL	154

6.2.1	Select a Situation That Needs Calibration	155
6.2.2	Required Calibration Tools	155
6.2.3	Calibration Preparations	156
6.2.4	Auxiliary Tool Positioning.....	157
6.3	LANE CHANGE ASSISTANT.....	170
6.3.1	Select a Situation That Needs Calibration	170
6.3.2	Select the Vehicle Parking Position	171
6.4	CAMERA SYSTEM REAR VIEW.....	195
6.4.1	Select a Situation That Needs Calibration	195
6.4.2	Required Calibration Tools	196
6.4.3	Calibration Preparations	196
6.4.4	Auxiliary Tool Positioning.....	197
6.5	HEAD UP DISPLAY.....	204
6.5.1	Select a Situation That Needs Calibration	204
6.5.2	Required Calibration Tools	204
6.5.3	Calibration Preparations	204
6.5.4	Start Calibration.....	205
6.5.5	Head-up Display Image Correction.....	206
6.6	NIGHT VISION SYSTEM.....	207
6.6.1	Select a Situation That Needs Calibration	207
6.6.2	Required Calibration Tools	207
6.6.3	Calibration Preparations	208
6.6.4	Auxiliary Tool Positioning.....	209
6.7	ON-BOARD CAMERA.....	216
6.7.1	Select a Situation That Needs Calibration	216
6.7.2	Select the Vehicle Parking Position	217
7	MAINTENANCE AND SERVICE	240
7.1	MAINTENANCE INSTRUCTIONS.....	240

7.1.1	Calibration Frame Maintenance.....	240
7.1.2	Target Maintenance.....	241
7.2	SERVICE PROCEDURES.....	242
7.2.1	Self-inspection.....	242
7.2.2	After-sales Services.....	243
7.2.3	Parts Replacement.....	245
7.2.4	Technical Support.....	246
7.2.5	Repair Service.....	248
7.2.6	Other Services.....	248
8	COMPLIANCE INFORMATION.....	249
9	WARRANTY.....	251
9.1	LIMITED ONE YEAR WARRANTY.....	251

INTENTIONALLY BLANK PAGE

1 Using This Manual

This manual contains device usage instructions.

Some illustrations shown in this manual may contain modules and optional equipment that are not included in your system. Contact your sales representative for availability of other modules and optional tools or accessories.

1.1 Conventions

The following conventions are used:

1.1.1 Bold Text

Bold text is used to highlight selectable items such as buttons and menu options.

Example:

- Tap **OK**.

1.1.2 Notes and Important Messages

1.1.2.1 Notes

A **NOTE** provides helpful information such as additional explanations, tips, and comments.

Example:

NOTE

New batteries reach full capacity after approximately 3 to 5 charging and discharging cycles.

1.1.2.2 Important

IMPORTANT indicates a situation which, if not avoided, may result in damage to the tablet or vehicle.

Example:

IMPORTANT

Keep the cable away from heat, oil, sharp edges, and moving parts. Replace damaged cables immediately.

1.1.3 Hyperlinks

Hyperlinks are available in electronic documents. Blue italic text indicates a selectable hyperlink; blue underlined text indicates a website link or an email address link.

1.1.4 Illustrations

As the illustrations used in this manual are samples, the actual testing screen may vary for each vehicle being tested. Observe the menu titles and on-screen instructions to make correct option selection.

The illustrations are based on the default settings in **ADAS & Aligner Settings**, you can change the settings according to your needs and actual situations. To change the default settings, please refer to [Aligner & ADAS Settings](#) for details.

The illustrations involving clamps in this manual are based on the use of rim clamps. Since the calibration procedures for using rim clamps and tire clamps are basically the same, the procedures of using tire clamps for calibration are not illustrated in this manual.

1.1.5 Procedures

An arrow icon indicates a procedure.

Example:

➤ **To use the camera**

1. Tap the **Camera** button. The camera screen opens.
2. Focus the image to be captured in the view finder.
3. Tap the camera icon on the right side of the screen. The view finder now shows the captured picture and auto-saves the taken photo.
4. Tap the thumbnail image on the top right corner of the screen to view the stored image.
5. Tap the **Back** or **Home** button to exit the camera application.

2 General Introduction

The Autel Intelligent ADAS IA900 Wheel Alignment & ADAS Calibration (hereinafter referred to as “IA900WA”) is an ultimate two-in-one solution, can exert its effectiveness on wheel alignment and ADAS calibration. With the help of the IA900WA, drivers are able to keep driving in a straight line, foresee possible dangers in advance, and so on. The IA900WA provides vehicle-specific, step-by-step instructions through the compatible diagnostic tablet, enabling the technician to perform efficient, accurate calibrations on vehicles.

2.1 Safety Instructions and Precautions

1. Check the power supply, make sure the power supply voltage is stable and properly grounded.
2. Carefully position the cord so that it does not snag or tangle.
3. To reduce the risk of electric shock, do not use it on rainy or wet ground.
4. Do not use or store the device in places with heavy smoke, dust and fog.
5. When the calibration frame is moved to the desired position, you should depress the footbrake to prevent the calibration frame from moving.
6. Avoid using the calibration frame in strong vibration and strong wind environment, as a shaky calibration frame will lead to inaccurate measurement results.
7. Read and follow all cautions and warning labels affixed to the calibration frame and other tools. Improper use may cause personal injury and shorten the life of the calibration frame.
8. Please follow the instructions in this manual to use the calibration frame and other tools.

2.2 Product Description

2.2.1 Calibration Frame

The IA900WA calibration frame is stably and reliably constructed. In consideration of usability and portability, it has a fine-tuning mechanism with four knobs, which is capable of adjusting the roll angle, pitch angle, yaw angle, crossbar position (left/right). The arms of the crossbar can be expanded and folded for easy storage and transportation. Six cameras (see [Camera Kit](#) for details), for detection and identification, are attached on the crossbar of the IA900WA, while the 24” LCD touchscreen monitor, for sharing the screen

with the tablet, is installed on the top of the calibration frame. With the help of the 12 V/24 V external power cord, the calibration frame can charge other Autel products, like Autel tablet, Autel NV (Night Vision) calibrator, and Autel radar calibration box.

NOTE

Since the crossbar can be folded, please ensure that the warning in the inner red column is visible before folding to prevent the cameras from striking the ground and getting damaged.

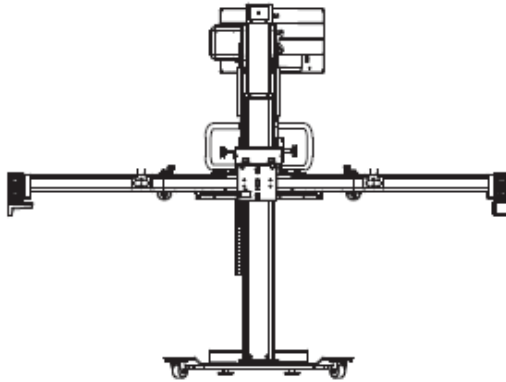

Figure 2-1 Calibration Frame AUTEL-CSC9000

NOTE



- A clear & level surface measuring 4 m/13.2 ft in length and 5.33 m/10.92 ft in width is required for placing the calibration frame.
- 10 m/32.8 ft long and 5 m/16.4 ft wide area is required for completing the whole wheel alignment and ADAS calibration.











Table 2-1 Calibration Frame Specifications



Item	Description
Model	AUTEL-CSC9000
Rated Power	260 W
Power Supply	100 ~ 264 V, 50/60 Hz
Calibration Frame Folded Dimensions	860 x 1240 x 1995 mm (33.86 x 48.82 x 78.54 in)

Item	Description
Crossbar Unfolded Length	2760 mm (108.66 in)
Crossbar Folded Length	1240 mm (48.82 in)
Calibration Frame Height Range	1880 ~ 2580 mm (74.02 ~ 101.57 in)
Crossbar Height Range	325 ~ 2175 mm (12.80 in)
Camera Numbers	6
Single Camera Pixel	3072*2048
Operating Temp.	-10 ~ 50 °C (14 °F ~ 122 °F)
Storage Temp.	-20 ~ 60 °C (-4 °F ~ 140 °F)
Compatible Tablet	MaxiSys Ultra

Table 2-2 Explanations of Symbols on the Calibration Frame

Symbol	Name	Explanation
	UP	Press it to lift the crossbar.
	DOWN	Press it to lower the crossbar.
	EMERGENCY STOP	Press it when in an emergency.

Symbol	Name	Explanation
	Press	Press it to secure the crossbar.
	Left/Right	Rotate it to adjust the crossbar position (left/right).
	Roll	Rotate it to adjust roll angle.
	Yaw	Rotate it to adjust yaw angle.
	Pitch	Rotate it to adjust pitch angle.
	USB Interface	For plugging in USB cord.
	HDMI Interface	For plugging in HDMI cord.
	Warning of Laser Beam	Warning mark.
	CAUTION	Warning mark.
	Infrared device inside. Avoid eye exposure.	Warning mark.
	Hot surface. Avoid contact.	Warning mark.

Symbol	Name	Explanation
	Protect from water	Warning mark.
	Protect from sunlight	Warning mark.
	Fragile	Warning mark.
	Protect from grease	Warning mark.

2.2.1.1 Fine-tuning Mechanism

The fine-tuning mechanism is on the middle part of the calibration frame, with four knobs for adjusting pitch angle, yaw angle, roll angle, and crossbar position (left/right), respectively.

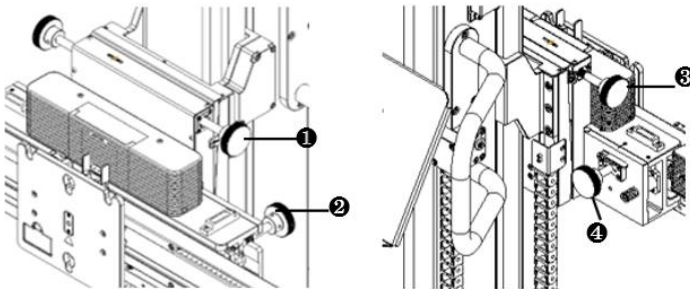

Figure 2-2 Fine-Tuning Mechanism

1. Pitch Angle Adjustment Knob
2. Yaw Angle Adjustment Knob
3. Roll Angle Adjustment Knob
4. Crossbar Position Adjustment Knob (Left/Right)

2.2.1.2 Folding Mechanism

There are two folding mechanisms for expanding or folding the left and right arms of the crossbar.

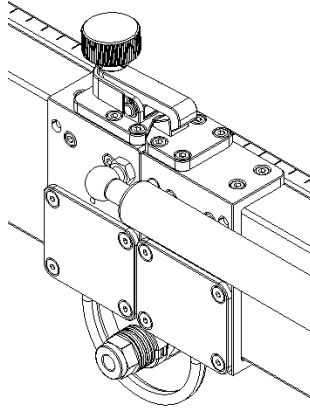

Figure 2-3 Folding Mechanism

2.2.1.3 Control Buttons

Three control buttons are available: EMERGENCY STOP button, UP button, and DOWN button. The EMERGENCY STOP button is used for stopping the crossbar from lifting and lowering in an emergency, the UP button is used for lifting the crossbar, while the DOWN button is used for lowering the crossbar.

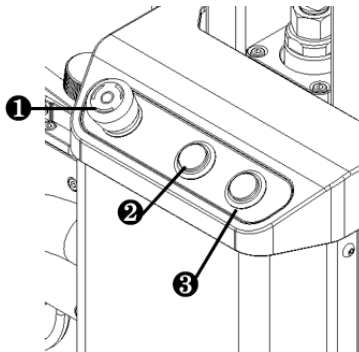

Figure 2-4 Control Buttons

1. EMERGENCY STOP Button
2. UP Button

3. DOWN Button

2.2.1.4 Footbrakes

There are two footbrakes on the back of the calibration frame. If you want to keep the calibration frame still, depress the footbrakes with your feet.

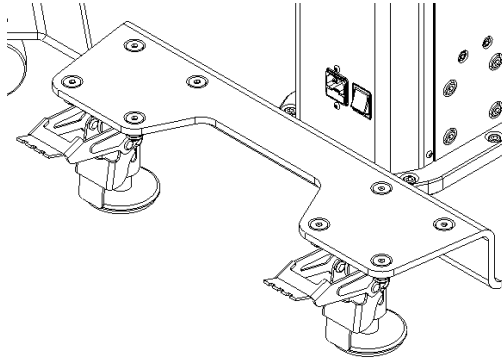

Figure 2-5 Two Footbrakes

2.2.1.5 Camera Kit

One center camera, one right camera unit, and one left camera unit, are installed on the crossbar. The camera kit is an essential part when performing ADAS calibration function and wheel alignment function.

NOTE

When facing the front of the calibration frame, the left camera unit is on the left side, the right camera unit is on the right side.

- Center Camera

The center camera is used to identify its designated target.

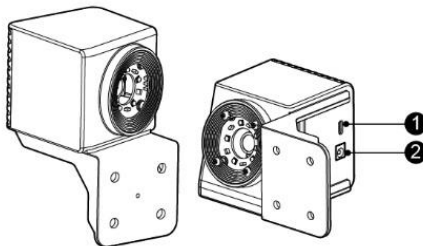

Figure 2-6 Center Camera AUTEL-CSC0500/18

1. USB Port
 2. Power Port
- Right Camera Unit

The right camera unit, featuring three cameras, is used to identify its designated target.

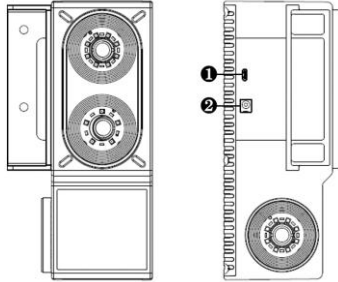

Figure 2-7 Right Camera Unit AUTEL-CSC0500/18

1. USB Port
 2. Power Port
- Left Camera Unit

The left camera unit, featuring two cameras, is used to identify its designated target.

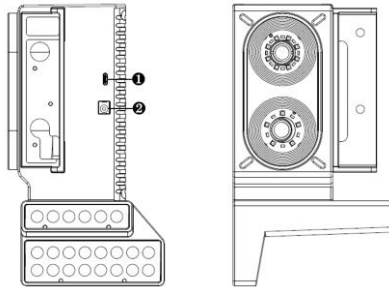

Figure 2-8 Left Camera Unit AUTEL-CSC0500/18

1. USB Port
2. Power Port

2.2.1.6 12 V/24 V External Power Cord

The 12 V/24 V external power cord is attached on the handle. Plug one end of the cord into the DC output port in the calibration frame, plug the 12 V input cord into the power input port of Autel tablet or Autel NV calibrator to let the calibration frame charge them. Or plug the 24 V input cord into the power input port of the radar calibration box, the calibration frame can also charge the radar calibration box.

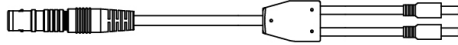

Figure 2-9 12 V/24 V External Power Cord

2.2.1.7 24" LCD Touchscreen Monitor

The monitor can share the screen with tablet automatically after completing the Wi-Fi connection between the calibration frame and the tablet.

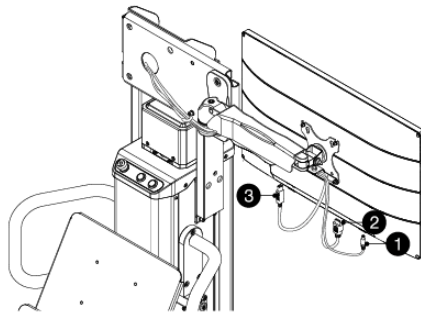

Figure 2-10 24" LCD Touchscreen Monitor

➤ To use the touchscreen monitor

1. Remove the protective film and foam padding around the touchscreen monitor.
2. Adjust the monitor to an appropriate position for viewing.

ⓘ NOTE

After removing the foam padding, check whether the Emergency Stop button is pressed down inadvertently. If so, rotate the button clockwise to release it.

3. Remove the protective film from the cables.
4. Plug the power cable (1), HDMI cable (2), and USB cable (3) into their respective input ports on the touchscreen monitor.
5. The touchscreen is now ready for use.

3 Accessories Introduction

3.1 Standard Accessories

Table 3-1 *Standard Accessories in Wheel Clamp (Rim Clamp) Version*

Name	Model	Quantity
Wheel Clamp (Rim Clamp)	AUTEL-CSC0500/19/LF AUTEL-CSC0500/19/RF AUTEL-CSC0500/19/LR AUTEL-CSC0500/19/RR	4 pcs
Target	AUTEL-CSC0500/16/LF AUTEL-CSC0500/16/RF AUTEL-CSC0500/16/LR AUTEL-CSC0500/16/RR	4 pcs
Brake Pedal Depressor	AUTEL-CSC0500/26	1 pc
Steering Wheel Holder Stand Tool	AUTEL-CSC0500/27	1 pc
Alignment Aid	AUTEL-CSC0500/08	1 pc
Hex L-wrench (5 mm) For Installing Alignment Aid	N/A	1 pc
Wheel Chock	N/A	2 pcs

Table 3-2 Standard Accessories in Wheel Clamp (Tire Clamp) Version

Name	Model	Quantity
Wheel Clamp (Tire Clamp)	AUTEL-CSC0500/17/LF AUTEL-CSC0500/17/RF AUTEL-CSC0500/17/LR AUTEL-CSC0500/17RR	4 pcs
Target	AUTEL-CSC0500/16/LF AUTEL-CSC0500/16/RF AUTEL-CSC0500/16/LR AUTEL-CSC0500/16/RR	4 pcs
Brake Pedal Depressor	AUTEL-CSC0500/26	1 pc
Steering Wheel Holder Stand Tool	AUTEL-CSC0500/27	1 pc
Alignment Aid	AUTEL-CSC0500/08	1 pc
Hex L-wrench (5 mm) For Installing Alignment Aid	N/A	1 pc
Wheel Chock	N/A	2 pcs

3.1.1.1 Wheel Clamp (Rim Clamp)

By vertically attaching to the wheel of the vehicle, the wheel clamp (rim clamp) AUTEL-CSC0500/19 is used to hold the designated target AUTEL-CSC0500/16, so that the camera kit can identify it.

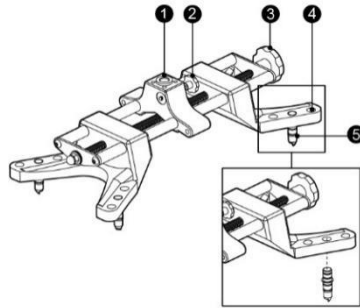

Figure 3-1 Wheel Clamp (Rim Clamp) AUTEL-CSC0500/19

1. Fixing Axle Slot — for inserting the fixing axle of the target.
2. Tightening Screw — for tightening the inserted fixing axle of the target.
3. Locking Knob — for tightening the wheel clamp (rim clamp) on the wheel.
4. Pawl Slots — according to wheel diameter, insert the pawls into suitable pawl slots.
5. Pawls — for attaching the wheel clamp (rim clamp) to the wheel.

3.1.1.2 Wheel Clamp (Tire Clamp)

There are four wheel clamps (tire clamps) in a kit, each wheel clamp (tire clamp) should be installed on the matching tire. For tires with different diameters, each wheel clamp (tire clamp) has three gears to adjust. The applicable tire diameters for each gear are as follows:

- First Gear: 19-27 inches
- Second Gear: 24-32 inches
- Third Gear: 30-37 inches

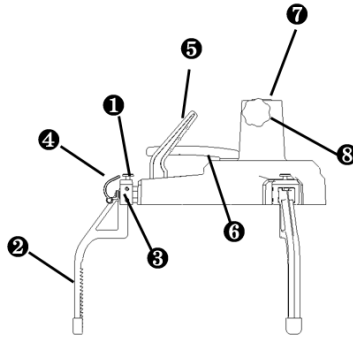

Figure 3-2 Wheel Clamp (Tire Clamp) AUTEL-CSC0500/17

1. Control Button
2. Pawl
3. Pawl Slot
4. Pull Handle
5. Lift Handle
6. Locking Handle
7. Fixing Axle Slot
8. Locking Knob

➤ **To assemble the wheel clamp (tire clamp)**

1. Hold the lift handle (5), press the control button (1) on the pawl slot (3).
2. Insert the matching pawl into the pawl slot.

NOTE

Be sure to install the pawl with pull handle first and install it into the pawl slot nearest the lift handle, and then install the other two pawls in the same way.

3. When the pawl is fully inserted into the pawl slot, release the control button — the pawl is installed well.
4. After all the three pawls are well installed, you can adjust the gear according to the tire diameter.
5. Press the control button, pull the pawls up or down to adjust the gear.
6. When you hear a "click", it indicates the gear has been adjusted successfully. You can then release the control button.

 **NOTE**

After adjusting the gear, when no number is displayed, it is in the first gear, you can only pull the pawls outward; when the number 2 is displayed, it is in the second gear; when the number 3 is displayed, it is in the third gear. Be sure the three pawls are in the same gear. Assemble the other three tire clamps as described above.

➤ **To install the target**

1. Once the wheel clamp (tire clamp) is assembled, take out the target that matches the tire clamp.
 2. Hold the lift handle (5) and release the locking knob (8).
 3. Insert the target positioning pin into the corresponding mounting hole so that the target can be inserted into the fixing axle slot (7).
 4. Tighten the locking knob after the target is well inserted.
-

 **NOTE**

The wheel clamp (tire clamp) and the target should be matched. For example, the left rear target should be installed on the left rear wheel clamp (tire clamp).

➤ **To install wheel clamp (tire clamp) on a tire**

1. Before installing wheel clamp (tire clamp) on a tire, be sure the target is installed well, and the gear is adjusted according to the tire diameter.
2. Hold the lift handle (5), and lift the pull handle (4) to install the wheel clamp (tire clamp) on the corresponding tire.
3. After all the pawls are tightly attached to the tire, release the pull handle and lock the locking handle (6).
4. The wheel clamp (tire clamp) with target is installed well.

3.1.1.3 *Target*

There are four targets. The front targets are inserted into the left front wheel clamps and right front wheel clamps, the rear targets are inserted into the left rear wheel clamps and right rear wheel clamps. All the four targets are used to accurately read the wheel alignment parameters.

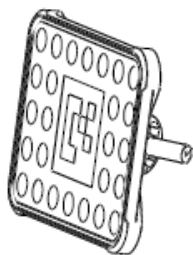

Figure 3-3 Target AUTEL-CSC0500/16

➤ **To install wheel clamp (rim clamp) and target on wheel**

1. Remove the covers from the pawls of the rim clamp.
2. Insert pawls into suitable pawl slots according to the wheel size (fits wheels between 14" and 23" in diameter).
3. Loosen the locking knob (3) to install the wheel clamp (rim clamp) on wheel.
4. Adjust according to needs, then tighten the locking knob to make the wheel clamp (rim clamp) installed on the wheel securely.
5. Loosen the tightening screw (2), insert the fixing axle of the target into the fixing axle slot (1) with target positioning pin inserting into the corresponding mounting hole. Tighten the tightening screw after the target is well installed.

NOTE

The wheel clamp (rim clamp) and the target should be matched. For example, the left rear target should be installed on the left rear wheel clamp (rim clamp).

3.1.1.4 Brake Pedal Depressor

It assists in depressing the brake pedal.

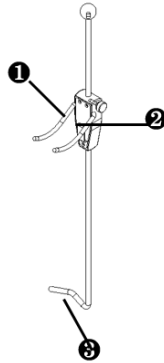

Figure 3-4 Brake Pedal Depressor AUTEL-CSC0500/26

1. Hook
2. Quick Release Adjustment System
3. Brake Pedal Contact Brace

➤ **To install the brake pedal depressor**

1. Snap the brake pedal into the brake pedal contact brace.
2. Press down hard, and adjust the quick release adjustment system to make the hooks stuck in the seat, thereby locking the brake pedal.

3.1.1.5 Steering Wheel Holder Stand Tool

The steering wheel holder stand tool is used to fix the steering wheel position and align the vehicle.

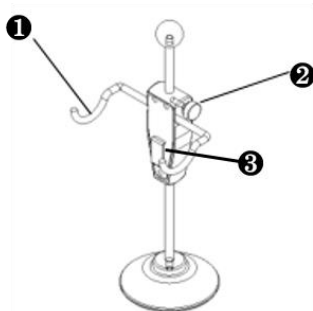

Figure 3-5 Steering Wheel Holder Stand Tool AUTEL-CSC0500/27

1. Hook
2. Locking Knob
3. Quick Release Adjustment System

➤ **To install the steering wheel holder stand tool**

1. Put the steering wheel holder stand tool on the seat.
2. Loosen the locking knob.
3. Adjust the quick release adjustment system so that the hooks contact the steering wheel, thereby limiting the rotation of the steering wheel.
4. Tighten the locking knob to fix it.

3.1.1.6 Alignment Aid

The alignment aid is used to measure the distance from the calibration frame to each position of the vehicle body.

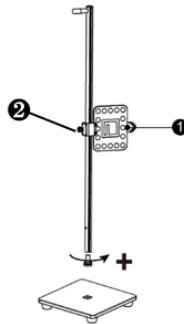

Figure 3-6 Alignment Aid AUTEL-CSC0500/08

1. Distance Measuring Target
2. Locking Knob

➤ **To install the alignment aid**

1. Secure the base and the rod with a screw and the hex L-wrench (5 mm) when using it for the first time.
2. Loosen the locking knob, attach the distance measuring target to the rod, then tighten the locking knob.

3.1.1.7 Wheel Chock

The wheel chock is placed behind the wheel to prevent your vehicle from rolling away.

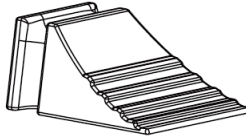
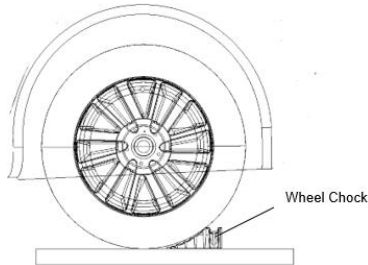

Figure 3-7 Wheel Chock

➤ **To place the wheel chock**

1. Park the vehicle on a flat place.
2. Wedge the wheel chock into the wheel as shown to prevent the wheel from rolling away.



3. Store away after use.

3.2 Other Needed Accessories (Not Equipped)

3.2.1 For Wheel Alignment and ADAS Calibration

Table 3-3 For Wheel Alignment and ADAS Calibration

Name	Model
Calibration Bar (for Rim Clamp)	N/A
Calibration Bar (for Tire Clamp)	N/A

Name	Model
MaxiSys Ultra Tablet	N/A

3.2.1.1 Calibration Bar

The calibration bar, with high measuring precision, is a professional tool for performing wheel alignment. When performing Aligner Calibration, or Accuracy Check, or Wheel Clamp Target Calibration, a calibration bar is required.

- **Suitable for Wheel Clamp (Rim Clamp)**

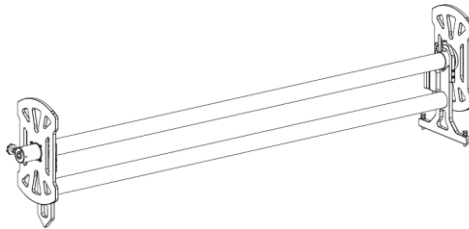

Figure 3-8 Calibration Bar — Suitable for Wheel Clamp (Rim Clamp)

- **To install wheel clamp (rim clamp) on the calibration bar**

1. Remove the covers from the pawls of the wheel clamp (rim clamp).
2. Insert pawls into suitable pawl slots according to the size of the calibration bar.
3. Loosen the locking knob of the wheel clamp (rim clamp) to install it on the calibration bar.
4. Adjust according to needs, then tighten the locking knob to make the wheel clamp (rim clamp) installed on the calibration bar securely.

- **Suitable for Wheel Clamp (Tire Clamp)**

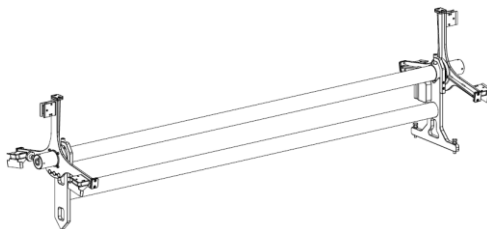

Figure 3-9 Calibration Bar — Suitable for Wheel Clamp (Tire Clamp)

➤ **To install wheel clamp (tire clamp) on the calibration bar**

1. Hold the lift handle, and lift the pull handle of the tire clamp to install the pawls into the slots on the calibration bar.
2. When the wheel clamp (tire clamp) is well installed on the calibration bar, rotate the locking handle to securely lock the wheel clamp (tire clamp) on the calibration bar.

3.2.1.2 *MaxiSys Ultra Tablet*

The IA900WA needs to be used with MaxiSys Ultra tablet, you can perform the wheel alignment and ADAS calibration function only when the IA900WA is connected to MaxiSys Ultra tablet.



Figure 3-10 *MaxiSys Ultra Tablet*

● **Software Activation**

Since the MaxiSys Ultra does not have Wheel Alignment function, so before performing the Wheel Alignment function, you need to activate the Wheel Alignment Application on the tablet first after purchasing a Wheel Alignment & ADAS Calibration Card from www.autel.com.

➤ **To activate the Wheel Alignment & ADAS Calibration Application**

1. Confirm the updates on registered MaxiSys Ultra tablet are available.
2. Select **Settings** on the main screen of the tablet.
3. Tap on **ADAS & Aligner Settings**.
4. Select the calibration frame you need to bind, then enter the validation code from the Wheel Alignment & ADAS Calibration Application Card.
5. Download the Wheel Alignment & ADAS Calibration Application software.

- **Calibration Frame Connection**

To establish a communication between the tablet and the IA900WA, the tablet needs to connect the tablet with calibration frame by connecting the IA900WA Wi-Fi.

- **To connect the tablet with the calibration frame**

1. After installing the monitor, plug the power cord at the bottom of the column into power socket, and then turn on the power switch to power up the calibration frame.
2. Turn on the tablet. Select **Settings** on the main screen of the tablet.
3. Tap on **ADAS & Aligner Settings** on the left of the screen.
4. Tap on **Calibration Frame Connection** on the right of the screen.

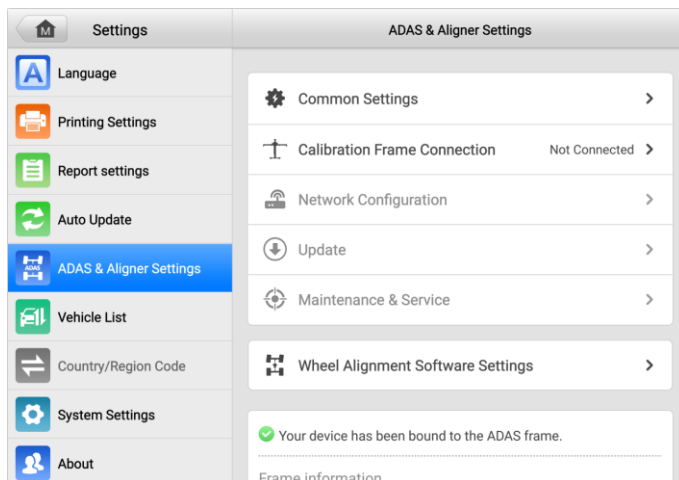

Figure 3-11 Connect IA900WA via Wi-Fi 1

5. Find the Wi-Fi name of the calibration frame and connect.
6. When the tablet is connected to the calibration frame, the communication status reads "Connected."

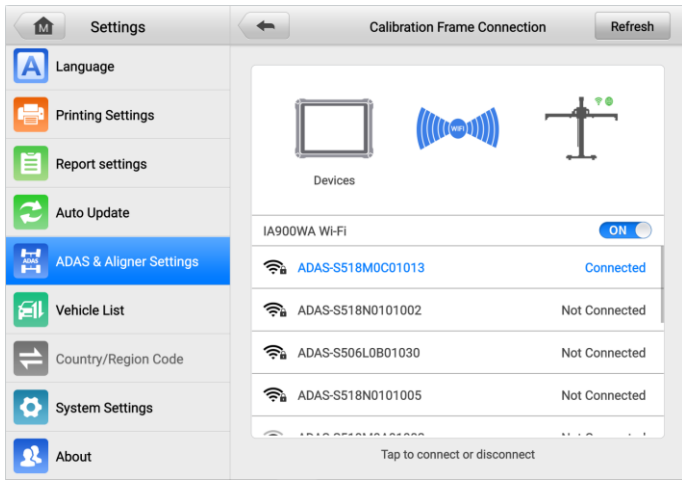

Figure 3-12 Connect IA900WA via Wi-Fi 2

- **Network Configuration**

After the tablet is connected to the IA900WA Wi-Fi, you need to connect the tablet to Internet accessible Wi-Fi through the following settings.

- **To connect the tablet to the Internet Accessible Wi-Fi**

1. Select **Settings** on the main screen of the tablet.
2. Tap on **ADAS & Aligner Settings** on the left of the screen.
3. Tap on **Network Configuration** (ensure the IA900WA Wi-Fi is connected, or it will not be activated).
4. Tap the drop-down button on the right side of the Wi-Fi name display box to select your Wi-Fi network, then enter the Wi-Fi password.

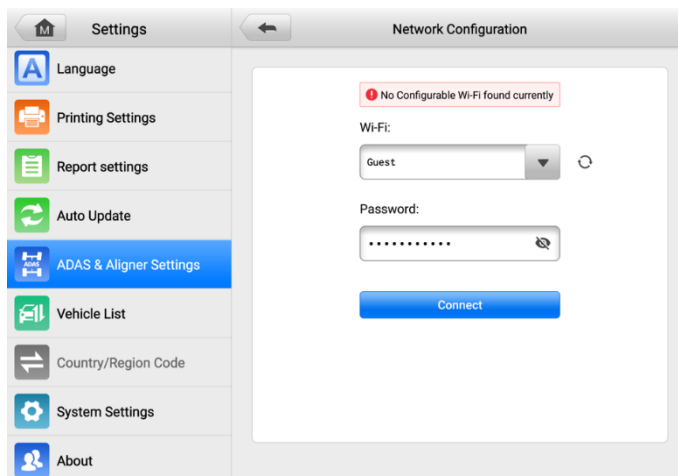

Figure 3-13 Connect to Internet Accessible Wi-Fi

5. Tap **Connect** once the Wi-Fi name is selected and the password is entered.
6. Tap the **Back** button to return to the previous page or tap the **Home** button to exit ADAS & Aligner Settings screen.

- **Establish Vehicle Communication**

Before performing wheel alignment and ADAS calibration function, proper communication between vehicle and MaxiSys Ultra tablet needs to be established.

- **To establish proper communication between vehicle and tablet**

1. Connect the VCI device to the vehicle's DLC for both communication and power source.
2. Connect the VCI device to the tablet via Bluetooth pairing, Wi-Fi or USB connection.
3. When the above steps are completed, check the VCI navigation button at the bottom bar on the screen, if a green BT, or Wi-Fi, or an USB icon displays at the lower right corner, the MaxiSys Ultra tablet is ready to perform wheel alignment and ADAS calibration function.

3.2.2 For ADAS Calibration

Table 3-4 For ADAS Calibration

Name	Model
Reflector	AUTEL-CSC0602/01
Mini Reflector	AUTEL-CSC0602/07
Calibration Stand	AUTEL-CSC0800
Accessories Kit I (For Japan & South Korea Vehicles)	N/A
Accessories Kit II (For Europe & U.S. Vehicles)	N/A
Target Board for Lane Departure Warning (LDW) System	N/A
Pattern Board (For LDW System)	N/A
Pattern Kit II (For AVM (Around View Monitoring) System)	N/A

3.2.2.1 Reflector

The reflector is required for positioning the calibration frame and calibrate radar.

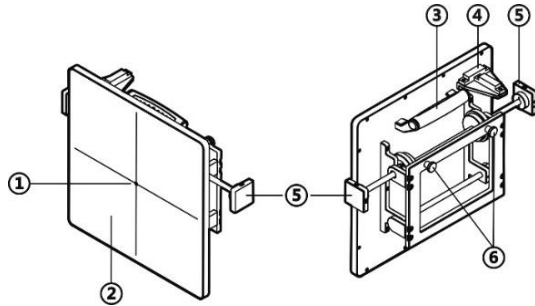

Figure 3-14 Reflector AUTEL-CSC0602/01

1. Laser Pass-thru Hole
2. Reflector Surface
3. Handle
4. Gradienter
5. Gear Knob — for different gears as required for different calibration.
6. Pothook

3.2.2.2 Mini Reflector

Together with laser on the calibration frame, mini reflector is used to adjust the reflector on the calibration frame parallel with the radar.

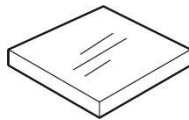

Figure 3-15 Mini Reflector AUTEL-CSC0602/07

3.2.2.3 Calibration Stand

Calibration stand is used to hold the corner reflector for radar calibration.

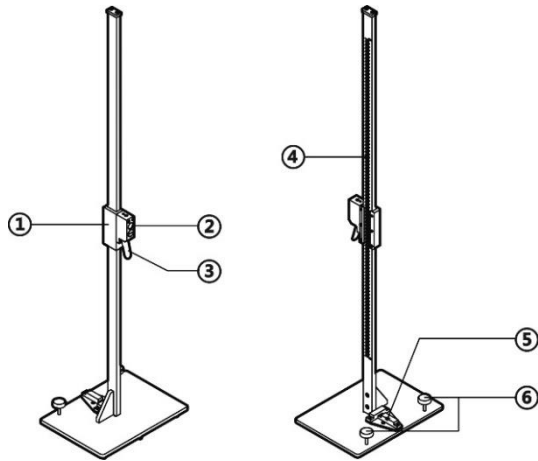

Figure 3-16 Calibrator Stand AUTEL-CSC0800

1. Fixing Lock — for tightening the mounting slot.
2. Mounting Slot — for mounting the fixing axle of the corner reflector or other calibration tools.
3. Handle
4. Ruler — for measuring the height.
5. Gradienter
6. Horizontal Adjusting Screws — for horizontal position adjustment of the sliding block height.

3.2.2.4 Accessories Kit I (For Japan & South Korea Vehicles)

● Radar Calibration Plate

By attaching to the sliding board on the calibration frame, Radar Calibration Plate AUTEL-CSC0602/02 is used for calibrating the Continental radar.

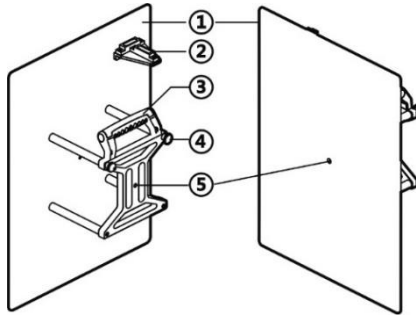

Figure 3-17 Radar Calibration Plate AUTEL-CSC0602/02

1. Plate Surface
2. Gradienter
3. Handle
4. Pothook
5. Laser Pass-thru Hole

● Corner Reflector

By attaching to the sliding board on the calibration frame, Corner Reflector AUTEL-CSC0802/01 is used for calibrating the millimeter-wave radar.

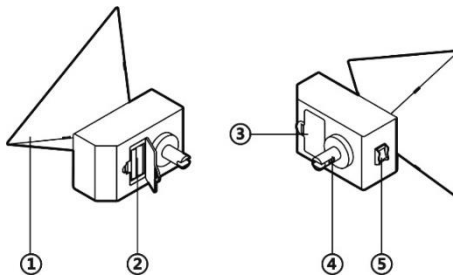

Figure 3-18 Corner Reflector AUTEL-CSC0802/01

1. Triangular Signal Receiving Board
2. 7# Dry Battery

3. Battery Box
4. Fixing Axle
5. Power Switch

- **ACC Target Board**

ACC Target Board AUTEL-CSC0802/03 is used for Adaptive Cruise Control system calibration on Nissan and Infiniti vehicles.



Figure 3-19 ACC Target Board AUTEL-CSC0802/03

- **Calibration Stand**

MaxiSys ADAS Calibration Stand Autel-CSC0802 is used for Radar calibration on Nissan, and Infiniti vehicles.

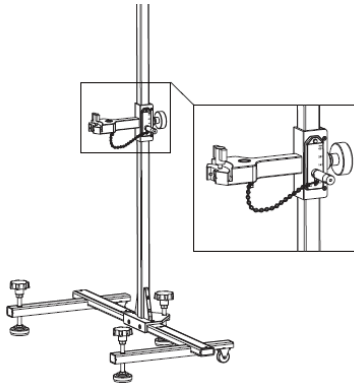

Figure 3-20 Calibration Stand Autel-CSC0802

3.2.2.5 Accessories Kit II (For Europe & U.S. Vehicles)

- **NV Calibrator (Volkswagen and GM vehicles)**

By attaching to the sliding board on the crossbar of the calibration frame, NV calibrator AUTEL-CSC0603/01 is used for night vision system calibration of Volkswagen and GM vehicles.

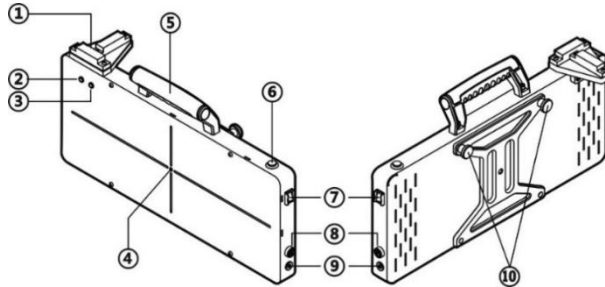

Figure 3-21 NV Calibrator AUTEL-CSC0603/01

1. Gradiometer
2. Power LED (Red)
3. Power LED (Green)
4. Laser Pass-thru Hole
5. Handle
6. Operating Switch
7. Power Switch
8. Fuse Socket
9. DC Power Supply Input Port
10. Pothook

- **NV Calibrator (Benz)**

NV calibrator AUTEL-CSC0803/01 is used for night vision system calibration of Benz vehicles.

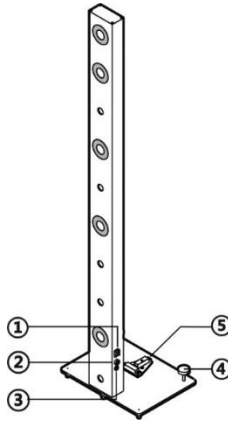

Figure 3-22 NV Calibrator (Benz) AUTEL-CSC0803/01

1. Power Switch
2. Fuse Socket
3. DC Power Supply Input Port
4. Horizontal Adjusting Screws
5. Gradienter

● **Radar Calibration Box**

By attaching to the sliding board on the crossbar of the calibration frame, Radar Calibration Box CSC0605/01 is used for blind spot detection system calibration of Volkswagen vehicles.

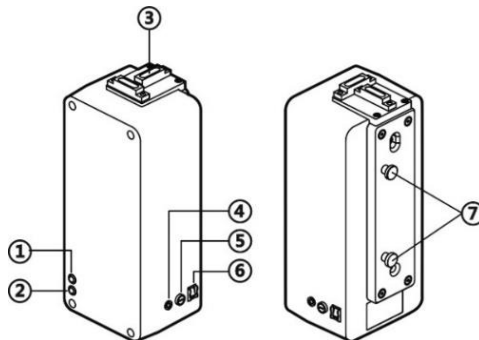

Figure 3-23 Radar Calibration Box AUTEL-CSC0605/01

1. Power LED (Green)
 2. Power LED (Red)
 3. Gradienter
 4. DC Power Supply Input Port
 5. Fuse socket
 6. Power Switch
 7. Pothook
- **Radar Calibration Plate**

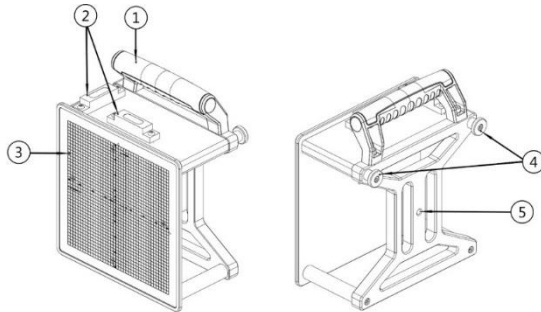

Figure 3-24 Radar Calibration Plate AUTEL-CSC0602/08

1. Handle
2. Gradienter
3. Scale Board
4. Installation Buckle
5. Laser Hole

- **Target Board**

Together with pattern AUTEL-CSC0806/01, target board AUTEL-CSC0804/01 is used for Around View Monitoring system calibration of Volkswagen vehicles.

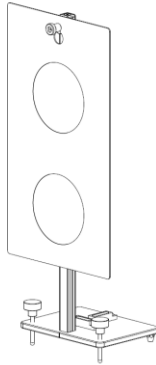

Figure 3-25 Target Board AUTEL-CSC0804/01

3.2.2.6 Target Board and Calibrator (for LDW System Calibration)

- **Target Board AUTEL-CSC0601/08-L**

Target Board AUTEL-CSC0601/08-L, for Lane Departure Warning system calibration on Honda vehicles.

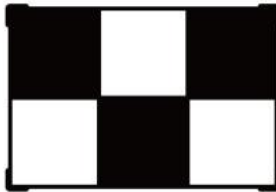

Figure 3-26 Target Board AUTEL-CSC0601/08-L

- **Target Board AUTEL-CSC0601/08-R**

Target Board AUTEL-CSC0601/08-R, for Lane Departure Warning system calibration on Honda vehicles.



Figure 3-27 Target Board AUTEL-CSC0601/08-R

- **Target Board AUTEL-CSC0601/05**

Target Board AUTEL-CSC0601/05, for Lane Departure Warning system calibration on Honda vehicles.



Figure 3-28 Target Board AUTEL-CSC0601/05

- **Target Board AUTEL-CSC0601/11**

Target Board AUTEL-CSC0601/11, for Lane Departure Warning system calibration on Toyota and Lexus vehicles (1).



Figure 3-29 Target Board AUTEL-CSC0601/11

- **Target Board AUTEL-CSC0601/15**

Target Board AUTEL-CSC0601/15, for Lane Departure Warning system calibration on Toyota vehicles (2).

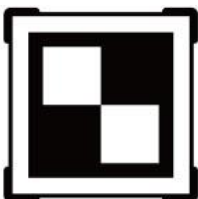

Figure 3-30 Target Board AUTEL-CSC0601/15

- **Target Board AUTEL-CSC0601/09**

Target Board AUTEL-CSC0601/09, for Lane Departure Warning system calibration on Hyundai and KIA vehicles.

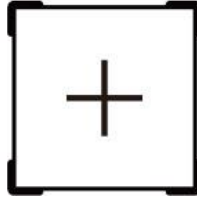

Figure 3-31 Target Board AUTEL-CSC0601/09

- **Target Board AUTEL-CSC0601/02**

Target Board AUTEL-CSC0601/02, for Lane Departure Warning system calibration on Mercedes Benz vehicles.

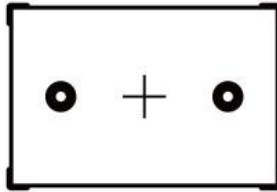

Figure 3-32 Target Board AUTEL-CSC0601/02

- **Target Board AUTEL-CSC0601/19**

Target Board AUTEL-CSC0601/19, for Lane Departure Warning system calibration on Benz vehicles (2).

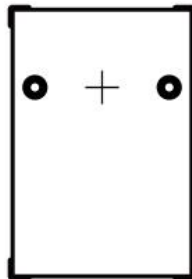

Figure 3-33 Target Board AUTEL-CSC0601/19

- **Target Board AUTEL-CSC0601/03-L**

Target Board AUTEL-CSC0601/03-L, for Lane Departure Warning system calibration on Nissan vehicles (1).

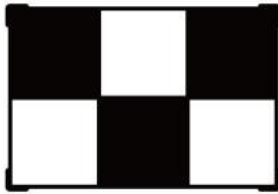

Figure 3-34 Target Board AUTEL-CSC0601/03-L

- **Target Board AUTEL-CSC0601/03-R**

Target Board AUTEL-CSC0601/03-R, for Lane Departure Warning system calibration on Nissan vehicles (1).



Figure 3-35 Target Board AUTEL-CSC0601/03-R

- **Target Board AUTEL-CSC0601/04-L**

Target Board AUTEL-CSC0601/04-L, for Lane Departure Warning system calibration on Nissan vehicles (3).

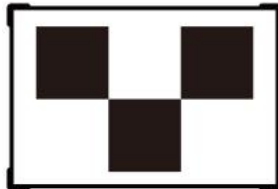

Figure 3-36 Target Board AUTEL-CSC0601/04-L

- **Target Board AUTEL-CSC0601/04-R**

Target Board AUTEL-CSC0601/04-R, for Lane Departure Warning system calibration on Nissan vehicles (3).

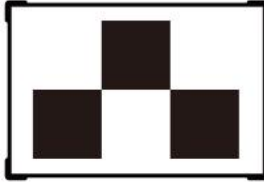

Figure 3-37 Target Board AUTEL-CSC0601/04-R

- **Target Board AUTEL-CSC0601/06-L**

Target Board AUTEL-CSC0601/06-L, for Lane Departure Warning system calibration on Nissan and Infiniti vehicles (2).

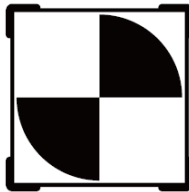

Figure 3-38 Target Board AUTEL-CSC0601/06-L

- **Target Board AUTEL-CSC0601/06-R**

Target Board AUTEL-CSC0601/06-R, for Lane Departure Warning system calibration on Nissan and Infiniti vehicles (2).



Figure 3-39 Target Board AUTEL-CSC0601/06-R

- **Target Board AUTEL-CSC0601/12**

Target Board AUTEL-CSC0601/12, for Lane Departure Warning system calibration on Mazda vehicles (1).

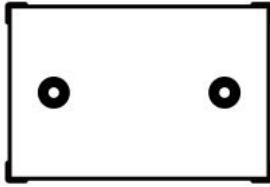

Figure 3-40 Target Board AUTEL-CSC0601/12

- **Target Board AUTEL-CSC0601/13-L**

Target Board AUTEL-CSC0601/13-L, for Lane Departure Warning system calibration on Mazda vehicles (2).



Figure 3-41 Target Board AUTEL-CSC0601/13-L

- **Target Board AUTEL-CSC0601/13-R**

Target Board AUTEL-CSC0601/13-R, for Lane Departure Warning system calibration on Mazda vehicles (2).



Figure 3-42 Target Board AUTEL-CSC0601/13-R

- **Target Board AUTEL-CSC0601/22-L**

Target Board AUTEL-CSC0601/22-L, for Lane Departure Warning system calibration on Mitsubishi vehicles.

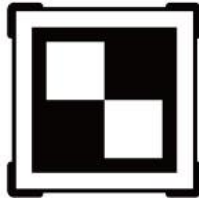

Figure 3-43 Target Board AUTEL-CSC0601/22-L

- **Target Board AUTEL-CSC0601/22-R**

Target Board AUTEL-CSC0601/22-R, for Lane Departure Warning system calibration on Mitsubishi vehicles.

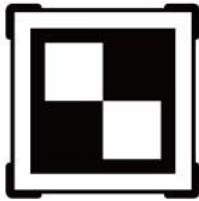

Figure 3-44 Target Board AUTEL-CSC0601/22-R

- **Front Camera Calibrator**

Front Camera Calibrator AUTEL-CSC0701/23, for Lane Departure Warning system calibration on Hyundai and KIA vehicles.

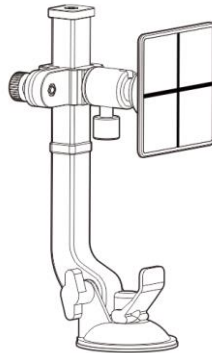

Figure 3-45 Front Camera Calibrator AUTEL- CSC0701/23

3.2.2.7 Pattern Board (for LDW System Calibration)

- **Pattern Board AUTEL-CSC0601/07**

Pattern Board AUTEL-CSC0601/07, for Lane Departure Warning system calibration on Hyundai and KIA vehicles (1). Target board holders used to secure board.

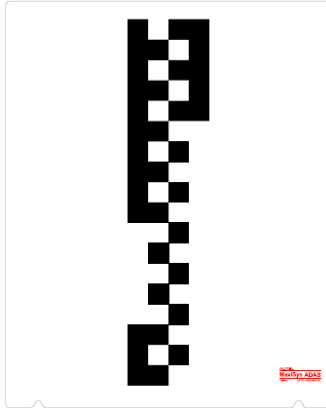

Figure 3-46 Pattern Board AUTEL-CSC0601/07

- **Pattern Board AUTEL-CSC0601/01**

Pattern Board AUTEL-CSC0601/01, used for Lane Keeping Assist (LKA) system calibration on Volkswagen and Porsche vehicles (1). Target board holders used to secure board.

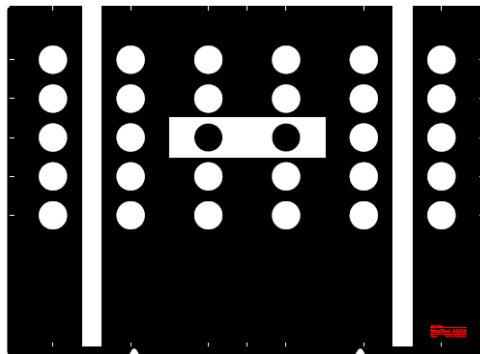

Figure 3-47 Pattern Board AUTEL-CSC0601/01

- **Pattern Board AUTEL-CSC0601/14-01**

Pattern Board AUTEL-CSC0601/14-01, used for calibrating LKA systems on Subaru vehicles. Target board holders used to secure board.

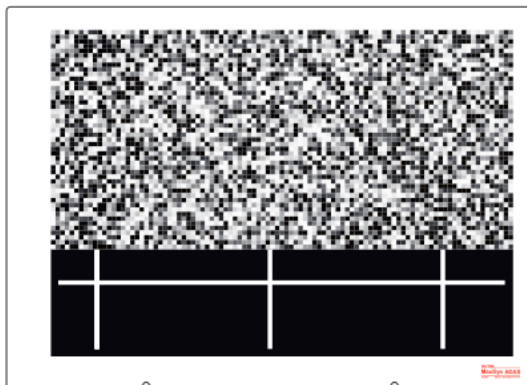

Figure 3-48 Pattern Board AUTEL-CSC0601/14-01

3.2.2.8 Patterns Kit II (for AVM System Calibration)

- **Pattern AUTEL-CSC0806/01**

Pattern AUTEL-CSC0806/01, used for Around View Monitoring system calibration on Volkswagen vehicles.

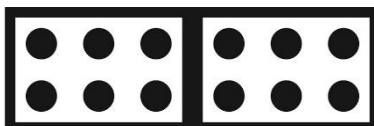

Figure 3-49 Pattern AUTEL-CSC0806/01

- **Pattern AUTEL-CSC1004/02**

Pattern AUTEL-CSC1004/02, used for Around View Monitoring system calibration on certain Honda vehicles (1).



Figure 3-50 Pattern AUTEL-CSC1004/02

- **Pattern AUTEL-CSC1004/03**

Pattern AUTEL-CSC1004/03, used for Around View Monitoring system calibration on certain Honda vehicles (2).

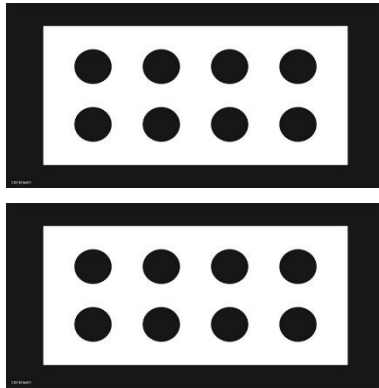

Figure 3-51 *Pattern AUTEL-CSC1004/03*

- **Pattern AUTEL-CSC1004/01**

Pattern AUTEL-CSC1004/01, used for Around View Monitoring system calibration on Volkswagen vehicles (2).



Figure 3-52 *Pattern AUTEL-CSC1004/01*

- **Pattern AUTEL-CSC1004/05**

Pattern AUTEL-CSC1004/05, used for Around View Monitoring system calibration on Ford vehicles.



Figure 3-53 *Pattern AUTEL-CSC1004/05*

- **Pattern AUTEL-CSC1004/06**

Pattern AUTEL-CSC1004/06, used for Around View Monitoring system calibration on Cadillac vehicles.



Figure 3-54 Pattern AUTEL-CSC1004/06

- **Pattern AUTEL-CSC1004/07**

Pattern AUTEL-CSC1004/07, used for Around View Monitoring system calibration on Porsche vehicles.



Figure 3-55 Pattern AUTEL-CSC1004/07

- **Pattern AUTEL-CSC1004/08**

Pattern AUTEL-CSC1004/08, used for Around View Monitoring system calibration on PSA vehicles.

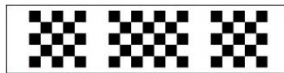

Figure 3-56 Pattern AUTEL-CSC1004/08

- **Pattern AUTEL-CSC1006/03**

Pattern AUTEL-CSC1006/03, used for Around View Monitoring system calibration on Nissan vehicles in non-Chinese area.

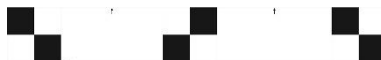

Figure 3-57 Pattern AUTEL-CSC1006/03

- **Pattern AUTEL-CSC1006/04**

Pattern AUTEL-CSC1006/04, used for Around View Monitoring system calibration on Nissan vehicles in China.



Figure 3-58 Pattern AUTEL-CSC1006/04

- **Pattern AUTEL-CSC1006/01**

Pattern AUTEL-CSC1006/01, used for Rear Collision Warning System on Benz vehicles.

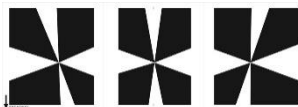

Figure 3-59 Pattern AUTEL-CSC1006/01

4 Wheel Alignment Function

The vehicle's four wheels, steering mechanism, and front and rear axles should have a certain relative position, this relative position is a standard value established by the manufacturer. However, the relative position may change after reinstalling the related components or driving the vehicle for a period of time, the procedure of adjusting and restoring to this position is called wheel alignment. After wheel alignment, the vehicle can be driven in a straight line as much as possible, the ease of steering control will be increased, the additional tire wear and power consumption will be decreased. Therefore, it is necessary to perform the wheel alignment before driving.

In this chapter, we will introduce the technical specifications, precautions in use, function buttons, wheel alignment preparations, and wheel alignment procedures, etc.

4.1 Technical Specifications

The technical specifications are shown in the table below.

Table 4-1 Technical Specifications

Item	Description
Recommended Working Distance	2667 mm (105 in)
Supported Axle Distance	2032 ~ 5588 mm (80 ~ 220 in)
Supported Wheel Distance	1270 ~ 2490 mm (50 ~ 98.03 in)
Supported Rim Diameter (Use Rim Clamp)	279 ~ 609 mm (11 ~ 24 in)
Supported Tire Diameter (Use Tire Clamp)	482.6 ~ 939.8 mm (19 ~ 37 in)
Crossbar Height Range	325 ~ 2200 mm (12.80 ~ 86.61 in)
Measurement Frequency (typ.)	9 times/s
Crossbar Lift Speed	50 mm/s

Item	Description
Operating Temp.	-10 ~ 50 °C (14 °F ~ 122 °F)
Storage Temp.	-20 ~ 60 °C (-4 °F ~ 140 °F)

4.2 Precautions in Use

1. When the vehicle is on the lift, make sure the front wheel is in the center of the steering wheel.
2. After the vehicle is driven on the lift, wheel chocks should be placed on front and rear of the two rear wheels to prevent the vehicle from rolling away.
3. Be careful when lifting the vehicle. Follow the safe operating procedures to lift vehicles.
4. When the vehicle is lifted to the required height, the vehicle can only be started after the insurance is in effect and safety is ensured.
5. Operating the lift is strictly forbidden when someone is working.
6. Make sure the camera lens and target are clean.
7. When wheel clamps are required, ensure the pawls on each wheel clamp are in the same gear.
8. Strictly follow the software procedures and prompts to operate.

4.3 Function Screens and Buttons

All the applications in the MaxiSys Ultra tablet are menu-driven. After a selection is made, the related screen will display. Each selection narrows the focus and leads to the desired. The function buttons on each screen are able to guide you to complete the wheel alignment procedures step by step.

4.3.1 Function Screens

The whole wheel alignment procedures are basically completed in the following screen. Follow the on-screen instructions to complete the wheel alignment procedures on the navigation bar one by one.

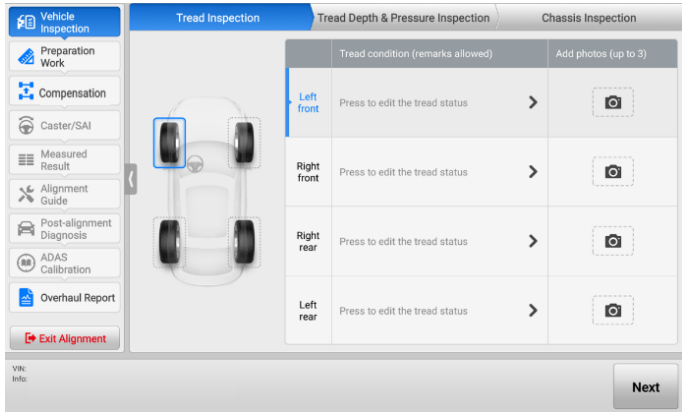

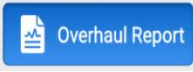
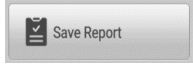

Figure 4-1 Whole Wheel Alignment Procedures Screen

4.3.2 Function Buttons

In this section, we are going to introduce some frequently-used function buttons (not all function buttons) on the tablet when performing wheel alignment.

Table 4-2 Function Buttons

Button	Name	Description
	Next	Tap to continue.
	Compensation	The tablet will enter Compensation screen after completing Preparation Work.
	Caster/SAI	Perform caster/SAI angle measurement function.
	Measured Result	Tap to save the measured result before wheel alignment.
	Alignment Guide	Guide you to perform wheel alignment.

Button	Name	Description
	Overhaul Report	Display the overhaul report after wheel alignment.
	Save Report	Tap to save as reports.
	Exit Alignment	Tap to exit the wheel alignment procedures.

4.4 Before Wheel Alignment

4.4.1 Preparatory Work

Before performing wheel alignment, please check and prepare:

1. The tablet is connected with IA900WA Wi-Fi and Internet accessible network. See [Calibration Frame Connection](#) and [Network Configuration](#) for details.
2. The ignition is turned off, and the IA900WA is connected to the charger to avoid the battery power loss, for the whole wheel alignment procedure may take a long time.
3. Prepare the following tools:
 - 1) Wheel clamps (rim clamps), wheel clamps (tire clamps), and targets
 - To install wheel clamps (rim clamps) and targets on wheels, see [Target](#).
 - To install wheel clamps (tire clamps) and targets on tires, see [Wheel Clamp \(Tire Clamp\)](#).

NOTE

Here we select wheel clamps (rim clamps) for illustration.

- 2) Turnplate
- 3) Steering wheel holder stand tool and brake pedal depressor
- 4) Wheel chock
- 5) Steering wheel level

4.4.2 Vehicle Communication and Selection

Tap **Wheel alignment** on the main screen of MaxiSys Ultra tablet, two options are available: Wheel Alignment and Advanced Wheel Alignment.

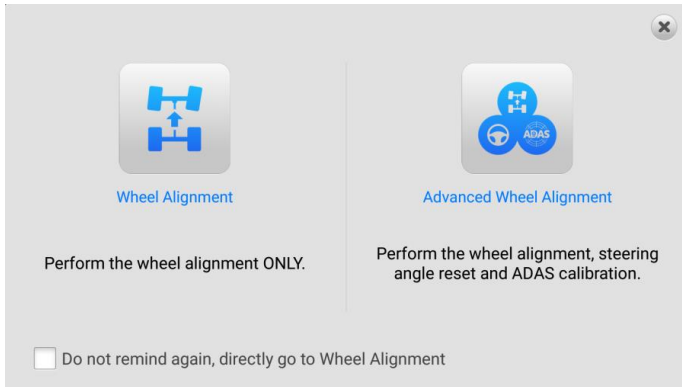

Figure 4-2 Wheel Alignment Function Entrance Screen

- 1) When you tap on **Wheel Alignment**, the tablet will guide you to perform the wheel alignment function only.
- 2) When you tap on **Advanced Wheel Alignment**, the tablet will guide you to perform the wheel alignment, steering angle reset and ADAS calibration function.

4.4.2.1 Wheel Alignment

1. If you select **Wheel Alignment**, the screen is as follows:



Figure 4-3 Vehicle Selection Screen (Wheel Alignment)

2. Establishing proper communication between vehicle and tablet by connecting the VCI device to the vehicle's DLC.
3. Select and tap on the manufacturer of your vehicle from the vehicle manufacturer buttons. Then follow the on-screen instructions to select the configuration information of your vehicle one by one.

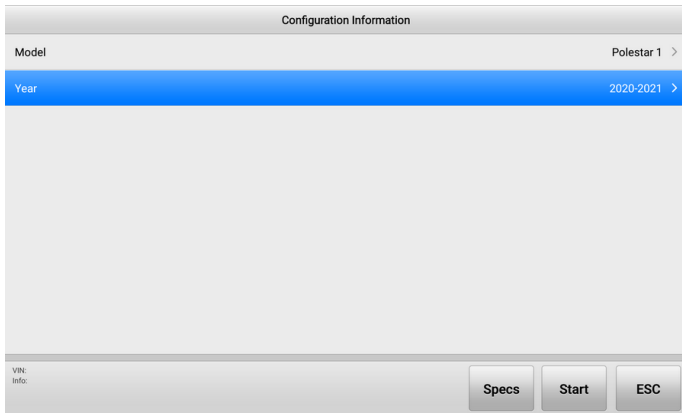

Figure 4-4 Select Configuration Screen 1 (Wheel Alignment)

4. Once the configuration information is completed, tap the **Specs** button to check and edit the alignment specifications. See [Wheel Alignment Parameters](#).
5. If the parameters related to wheel alignment are correct, tap **Start** and follow the screen step by step to continue, finally enter the whole wheel alignment procedures screen. See [Figure 4-1 Whole Wheel Alignment Procedures Screen](#).

4.4.2.2 Wheel Alignment Parameters

After selecting the vehicle configuration information, the **Specs** button is available in the function buttons section. This button is used to customize the wheel alignment parameters, it is suitable for vehicles which the parameters are different from those in original factory after chassis modification.

1. Tap the **Specs** button, you can check all the wheel alignment parameters.

Front specifications		Rear specifications	
Front	Spec.	Measurement (Min.)	Measurement (Max.)
Total toe	0°07'	-0°05'	0°19'
Left toe	0°04'	-0°02'	0°10'
Right toe	0°04'	-0°02'	0°10'
Left camber	1°05'	0°23'	1°47'
Right camber	1°05'	0°23'	1°47'
Cross camber	0°00'	-0°42'	0°42'
Left caster	5°43'	5°07'	6°19'
Right caster	5°43'	5°07'	6°19'

path: Polestar 1 / 2020-2021 / Default specifications

VIN Info: Edit Unit Setting Start ESC

Figure 4-5 Alignment Specifications Screen

- If there are any parameters need to be edited, tap the **Edit** button on the function buttons section.

Front specifications		Rear specifications			
Front	Spec.	Measurement (-Tol.)	Measurement (+Tol.)	Adjustment (-Tol.)	Adjustment (+Tol.)
Total toe	0°07'	0°12'	0°12'	--	--
Total toe (raised)	--	--	--	--	--
Left toe	0°04'	0°06'	0°06'	--	--
Right toe	0°04'	0°06'	0°06'	--	--
Cross toe	--	--	--	--	--
Left camber	1°05'	0°42'	0°42'	--	--
Right camber	1°05'	0°42'	0°42'	--	--
Cross camber	0°00'	0°42'	0°42'	--	--

path: Polestar 1 / 2020-2021 / Default specifications

VIN Info: Save As Unit Setting Start ESC

Figure 4-6 Edit Alignment Specifications Screen

- Tap and delete the parameters that need to be edited and enter the correct parameters. Then tap **Save** or **Save As** to enter Save Specifications screen.

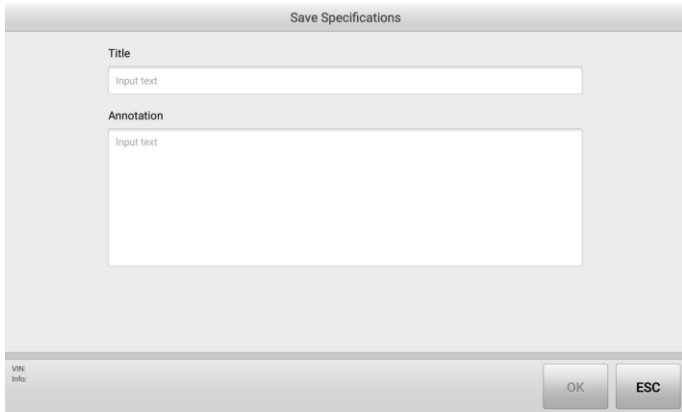

Figure 4-7 Save Specifications Screen 1

4. Input the vehicle model and annotation for the specifications, so that you can better distinguish and find them.
5. After entering the vehicle model and annotation for the parameters, tap **OK** to save the parameters.

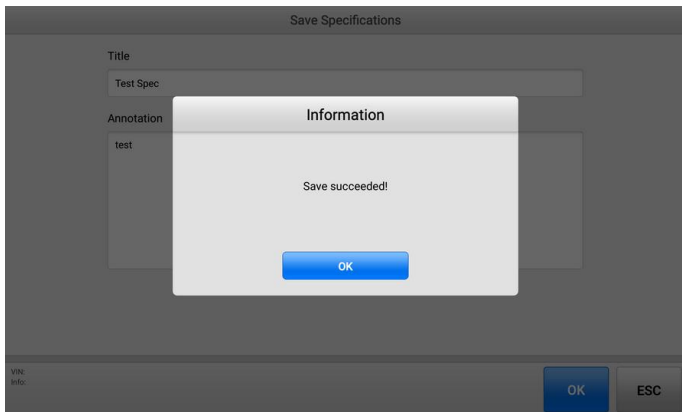

Figure 4-8 Save Specifications Screen 2

6. After editing and saving all parameters, the tablet will return to Wheel Alignment Parameters screen, then tap the **ESC** button, the saved parameters for the vehicle will be selected on the configuration information screen.

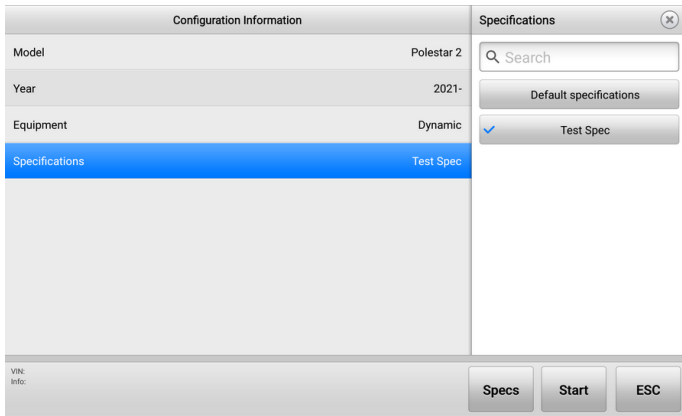

Figure 4-9 Select Configuration Screen 2 (Wheel Alignment)

- Then tap **Start** and follow the screen step by step to continue, and finally enter the whole wheel alignment procedures screen. See [Figure 4-1 Whole Wheel Alignment Procedures Screen](#).

4.4.2.3 Advanced Wheel Alignment

- If you select **Advanced Wheel Alignment**, the screen is as follows (the same as the screen on Diagnostics application):

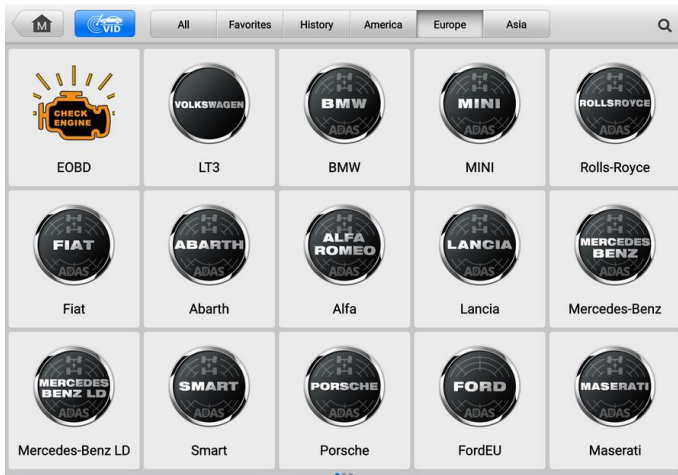

Figure 4-10 Vehicle Selection Screen (Advanced Wheel Alignment)

- Establishing proper communication between vehicle and tablet by connecting the VCI device to the vehicle's DLC.

- Tap the **VID** button to connect your vehicle by auto VIN detect, or manual VIN input, or VIN/License scanning. Or you can tap on the manufacturer of your vehicle from the vehicle manufacturer buttons, and finally enter the following screen (the screen may vary by vehicles, please refer to the actual screen on your tablet).

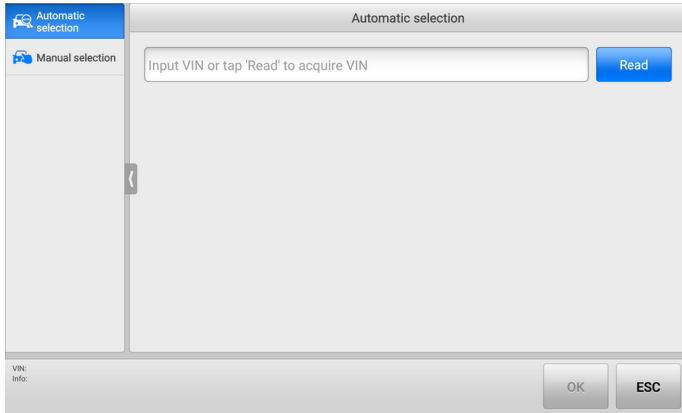

Figure 4-11 Acquire VIN Screen (Advanced Wheel Alignment)

- Here we select **Automatic selection** for illustration, tap **Read** to acquire VIN information. After the VIN is acquired, tap **OK** to confirm the vehicle information. Then tap **OK** to enter the main function screen, select the **Wheel Alignment** in the navigation bar. After that, selecting the situations that need for performing wheel alignment in the right of the screen.

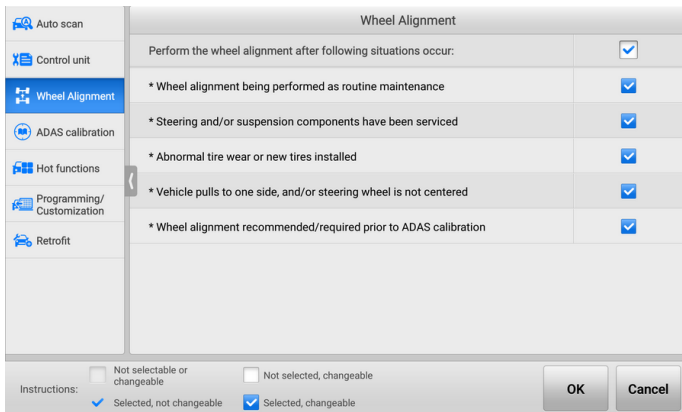

Figure 4-12 Wheel Alignment Screen (Advanced Wheel Alignment)

- Tap **OK** after the situations are selected to complete the configuration information.

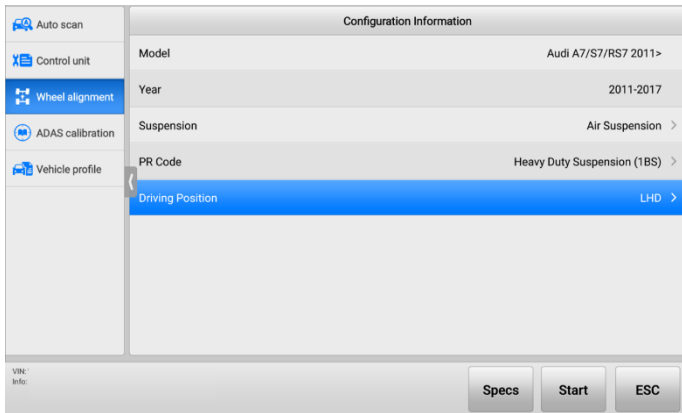

Figure 4-13 Complete Configuration Information (Advanced Wheel Alignment)

6. Once the configuration information is completed, tap the **Specs** button to check and edit the wheel alignment parameters. See [Wheel Alignment Parameters](#).
7. Tap **Start** after checking and editing the wheel alignment parameters. Then follow the screen step by step to continue, and finally enter the whole wheel alignment procedures screen. See [Figure 4-1 Whole Wheel Alignment Procedures Screen](#).

4.5 Wheel Alignment Procedures

4.5.1 Vehicle Inspection

1. Before performing wheel alignment, the tire tread condition and tread depth should be checked first, as tire abnormality will affect the wheel alignment test results.
2. Before performing wheel alignment, the tire pressure also needs to be checked and adjusted to the standard value for the vehicle. This is because the deviation of the pressure will affect the wheel alignment test results.
3. Chassis components can be inspected by fault type or vulnerability.

! IMPORTANT

Before performing wheel alignment procedures, please check the settings from **Settings** -> **ADAS & Aligner Settings** -> **Wheel Alignment Software Settings**, you can change the settings according to your needs and actual situation. The whole wheel alignment procedures in this manual are based on the default settings in **ADAS & Aligner Settings**.

4.5.1.1 Tread Inspection

a) Tread condition (remark allowed) column

According to the condition of the four tires, tap the tread status description area to add or edit each tread status of the vehicle. The tread condition includes Normal, Outside wear, Inside wear, Bilateral wear, Feather edge, Spot wear, Aging, Flat crushing, Excessive wear, Bulge, Wear/Puncture, Different tread/brand on one axle, Tire valve aging, Rim damage, and Unauthorized tire. Notes can be added when the tire is abnormal. Once the tread conditions of all tires are selected, tap **OK**. Then check the color of the four tires on the screen, if the color of the tire is red or yellow, replace or repair the tire according to the specific situation before tapping **Next**.

b) Add photos column

In order to judge and view the tread status better, you can tap the camera icon in the add photos column to add up to three photos of each tread respectively.

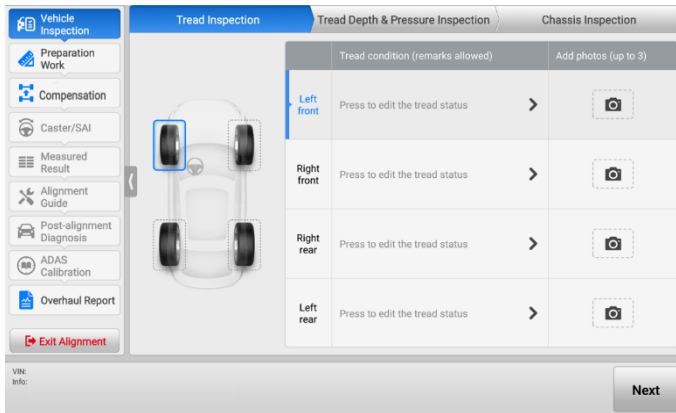

Figure 4-14 Tread Inspection Screen

4.5.1.2 Tread Depth & Pressure Inspection

When performing vehicle check, it is also necessary to check the tread depth & pressure.

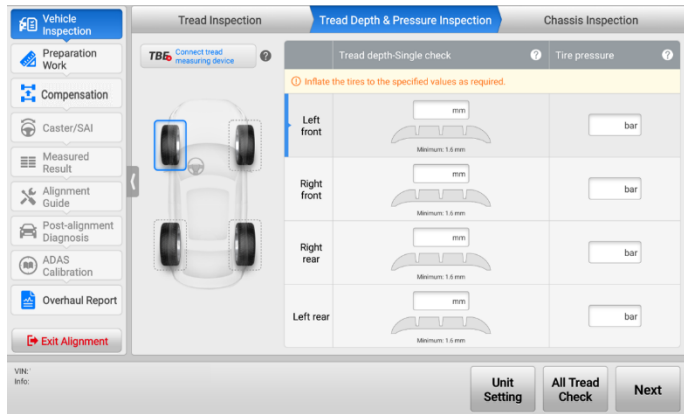

Figure 4-15 Tread Depth & Pressure Inspection Screen 1

1. Tread Pressure Inspection

- a) Input the standard tread pressure into the corresponding input box. The standard tire pressure is found on the tire and loading information placard, normally located on the B-pillar.

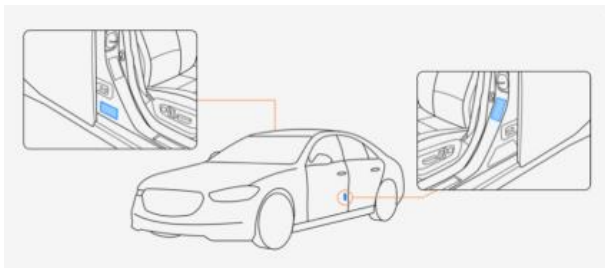

Figure 4-16 Standard Tire Pressure Value Location

2. Tread Depth Inspection

- a) There are All Tread Check and Single Check two modes for measuring tread depth. All Tread Check, measuring the tread depth at three positions including outside, middle and inside of the tire (nearest the vehicle body); while the Single Check is only to measure the tread depth at one of the following positions: outside, middle or inside of the tire (nearest the vehicle body). You can tap **All Tread Check** or **Single Check** to change the check mode.
- b) To measure the tread depth, Autel MaxiTPMS TBE series device (hereinafter referred as to TBE device) or other tread depth measurement tools is required. If you use TBE device to measure the tread depth, the values will be automatically displayed in the corresponding input box, if you use other tools to

measure the tread depth, you need to enter the values into the corresponding input box manually.

NOTE

After entering all the tread depth values and tread pressure values, check the color of the four tires on the screen, replace or repair the tire according to the specific situation.

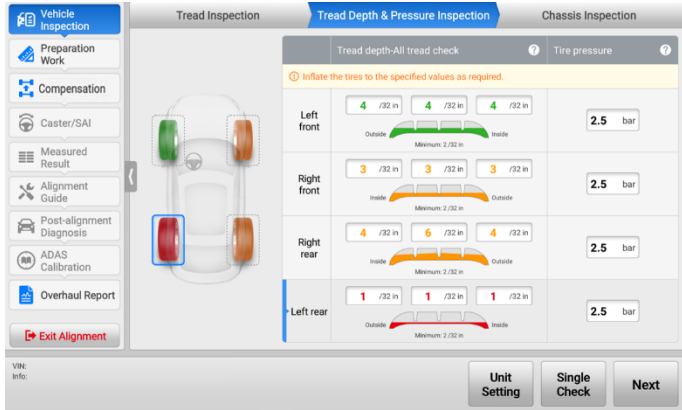

Figure 4-17 Tread Depth & Pressure Inspection Screen 2

NOTE

When measuring tread depth, the MaxiTPMS TBE200 (Not included. Please contact local dealers to purchase) needs to be connected, the diagnostic tool can automatically recognize the uploaded tread depth data. The data can also be synchronized by pressing **Load Tread Data**.

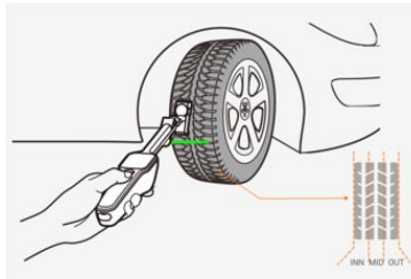

Figure 4-18 MaxiTPMS TBE Device (not included) and Use Diagram

➤ **To connect with MaxiTPMS TBE Device**

1. Tap **Connect Tread Measuring Tool** from **ADAS & Aligner Settings**.
2. Tap the **ON/OFF** button on the right of the screen to search available device(s).

3. Follow the screen guides to connect TBE device and the diagnostic tool to the same Wi-Fi.

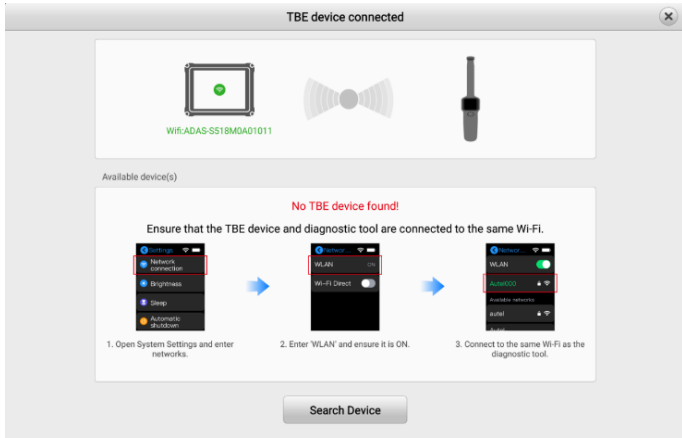

Figure 4-19 Connect with MaxiTPMS TBE Device 1

4. After the TBE device and the diagnostic tool are connected to the same Wi-Fi, tap the device you need in the available devices list to connect. Once the MaxiTPMS TBE device is connected, the connection status displays as “Paired.”

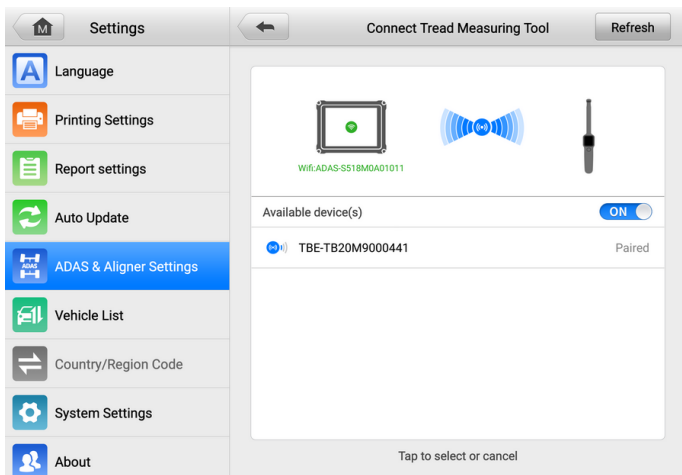

Figure 4-20 Connect with MaxiTPMS TBE Device 2

5. Exit the TBE connection screen after the TBE device is connected.

4.5.1.3 Chassis Inspection

Performing a chassis inspection can quickly and accurately troubleshoot the failure of chassis components, and record the chassis inspection process.

Inspecting the chassis is mainly to inspect eight systems, including Drivetrain, Engine and transmission accessories, Front suspension, Rear suspension, Front brake, Master cylinder and booster, Rear brake and Steering. Each system has several subdivided inspection items. You can follow the operation guides on the tablet to inspect all the eight systems one by one, and you can also inspect some of the items by filtering. Tap one of the inspection items, the component introduction, related symptoms, and repair method will be shown on the main section. Moreover, some inspection items have component schematic diagrams.

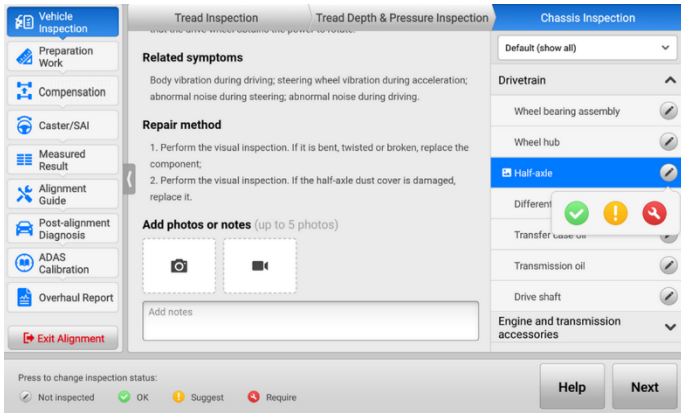

Figure 4-21 Chassis Inspection Screen 1







- a) According to the condition of the parts, you can tap the  icon to change the inspection status. For the explanation of each inspection status icon, you can tap the **Help** button for details.

Table 4-3 Inspection Status

Icon	Name	Explanation
	Not inspected	The part has not been inspected yet.
	OK	The part has been inspected, and no damage or wear is found.

Icon	Name	Explanation
	Suggest	<ol style="list-style-type: none"> 1. Part is close to the end of its useful life (just above discard specification, a failure may occur soon). 2. To address a customer need, convenience or request (improve ride comfort, eliminate noise, etc.). 3. To comply with maintenance recommended by the Original Equipment Manufacturer (OEM). 4. Technician's recommendations based on substantial and informed experience. (Note: suggested service should always be optional. All the facts should be presented to the customer, allowing the customer to draw his own conclusions.)
	Require	<ol style="list-style-type: none"> 1. Part no longer performs the intended purpose. 2. Part does not meet a design specification. 3. Part is missing. (Note: when a repair is required, the shop must present all the facts to the customer and refuse partial service to the system in question, if the repair creates or continues an unsafe condition.)

- b) Tap the  button in the main section, you are able to take and upload up to 5 photos of the related component. But be noted that the button will disappear when more than 5 photos are taken. Tap the  button, you can take and upload a video about the related component with a duration of 2 to 10 s. Please note that if the video duration is less than 2 s, the video recording is invalid. The button will disappear after shooting a video.
- c) Tap the drop-down box in the upper right corner of the screen, the parts that need to be inspected can be displayed in categories.

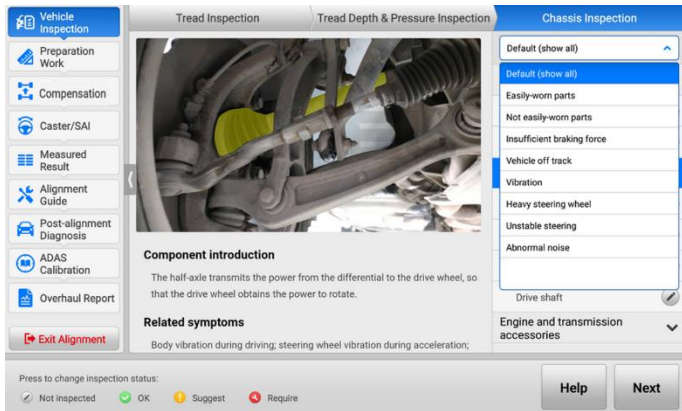

Figure 4-22 Chassis Inspection Screen 2

4.5.2 Preparation Work

For performing wheel alignment, the OE of some vehicle models has special requirements. In order to ensure the accuracy of the measurement results, the following preparations may be required before measuring the parameters related to wheel alignment.

1. Pre-alignment Notes
2. Diagnostic Functions
3. Ride Height Measurement

4.5.2.1 Pre-alignment Notes

Whether the vehicle's fuel tank, the spare tire, and the jack, are in their dedicated locations, will affect the measurement results during wheel alignment. Whether the comfort system of some advanced vehicle models is turned off will affect the installation of the brake pedal depressor and steering wheel holder stand tool. The OE has strict requirements on them. Therefore, it is necessary to carefully check the status of the vehicle according to the pre-alignment notes before performing wheel alignment.

According to the OE process, the pre-alignment notes vary by vehicle models. You need to carefully read and follow the pre-alignment notes.

Sample 1:

Check the vehicle status, this is an easy overlook but very important step.

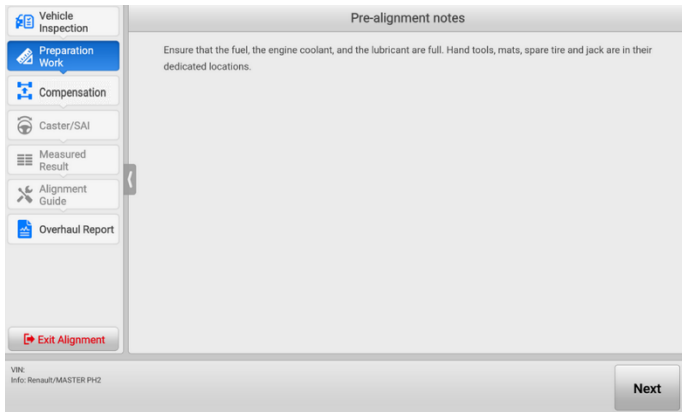

Figure 4-23 Pre-alignment Notes 1

Sample 2:

For Mercedes-Benz vehicles, the operating procedures of disabling easy entry & exit will be listed on the Pre-alignment notes screen. You need to follow the instructions to disable easy entry & exit function before performing wheel alignment.

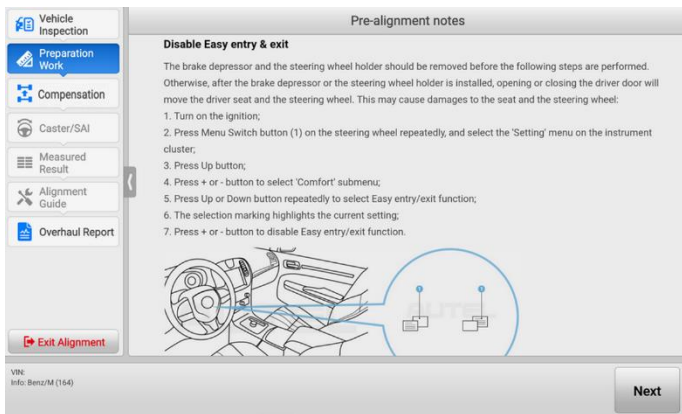

Figure 4-24 Pre-alignment Notes 2

4.5.2.2 Diagnostic Functions

To ensure the accuracy of the measurement results and the wheel alignment procedures can be performed successfully, the OE process of some vehicle models requires performing related diagnostic function (such as height adjustment, mode selection, RDC reset, etc.) before measuring wheel alignment parameters.

NOTE

1. The diagnostic functions are only performed when you select **Advanced Wheel Alignment** in Wheel alignment application, or the **Wheel Alignment** function in Diagnostics application.
2. The diagnostic functions vary by vehicle models. In the process of performing the diagnostic function, you need to read the notes carefully and follow the steps shown on the screen to operate.

◇ Height Adjustment (Take BMW vehicles as an example):

The height adjustment is required before measuring ride height in Load mode.

➤ To perform height adjustment

1. Follow the guides shown on the screen, please ensure that the following conditions are met:
 - 1) The brake pedal depressor is already removed.
 - 2) The ignition is ON.
 - 3) The engine is OFF.
 - 4) The VCI is connected properly.

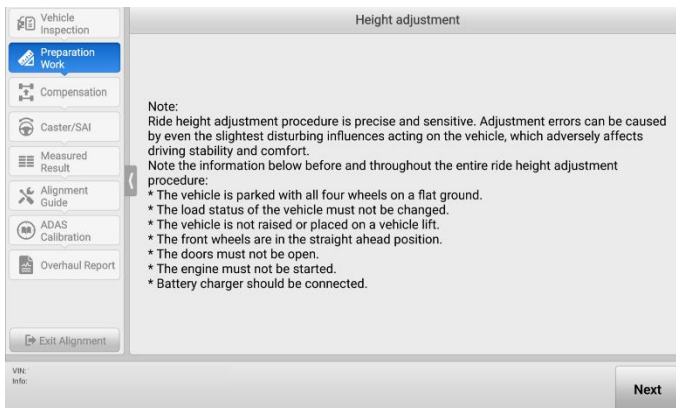

Figure 4-25 Height Adjustment Screen 1

2. If all the above conditions are met, tap **Next** to continue. Since the ride height adjustment procedure is precise and sensitive, adjustment errors can be caused by even the slightest disturbing influences acting on the vehicle, which adversely affects driving stability and comfort, so please carefully read the precautions for height adjustment and operate as required:
 - 1) The vehicle is parked with all four wheels on a flat ground.
 - 2) The load status of the vehicle must not be changed.
 - 3) The vehicle is not raised or placed on a vehicle lift.
 - 4) The front wheels are in the straight ahead position.
 - 5) The doors must not be open.
 - 6) The engine must not be started.
 - 7) Battery charger should be connected.

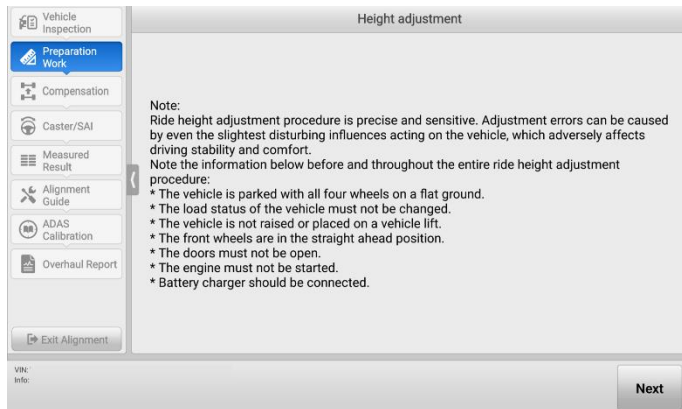

Figure 4-26 Height Adjustment Screen 2

3. Tap **Next** to continue if all the above conditions are met. The tablet will guide you to measure and enter the corresponding vehicle height value according to the actual situation.

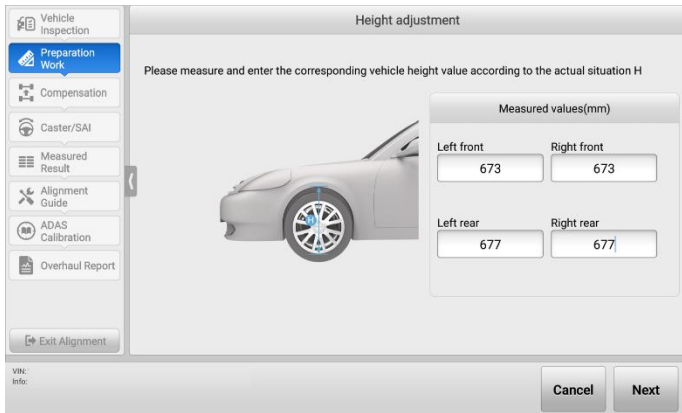

Figure 4-27 Height Adjustment Screen 3

- After measuring and entering the vehicle height values, tap **Next** to write the values to the Vertical Dynamics Platform (VDP) control unit.



Figure 4-28 Height Adjustment Screen 4

- Tap **Next** to continue. If the tablet displays the following screen, it indicates the ride height adjustment was successful.

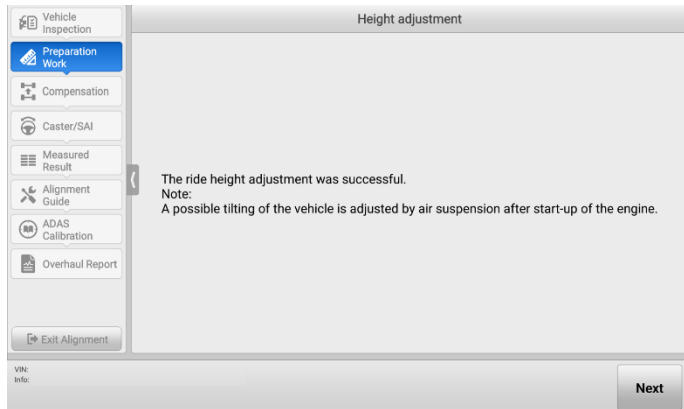

Figure 4-29 Height Adjustment Screen 5

4.5.2.3 Ride Height Measurement

The ride height measurement needs to be performed when the following conditions exist in the OE process of some vehicle models:

1. There is a standard value for the ride height.
2. The ride height value affects the standard value for wheel alignment.

NOTE

If the measured ride height value is not within the range of the standard value for ride height, you need to check if the vehicle body or the component on chassis is deformed or damaged.

1. Measure with tape or other tools
 - a) For some vehicles, such as Volkswagen, there is a standard ride height. You can use tape measure or other tools to measure the ride height, and enter the values into corresponding input box.

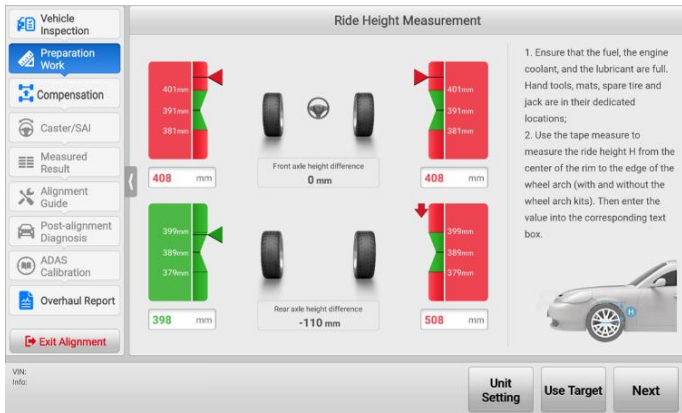

Figure 4-30 Measure Ride Height with Tape 1

- b) For some vehicles, such as Renault, there is no standard value for the ride height or a single tire needs to measure more than one value. You can also use tape measure or other tools to measure the ride height, and enter the values into corresponding input box.

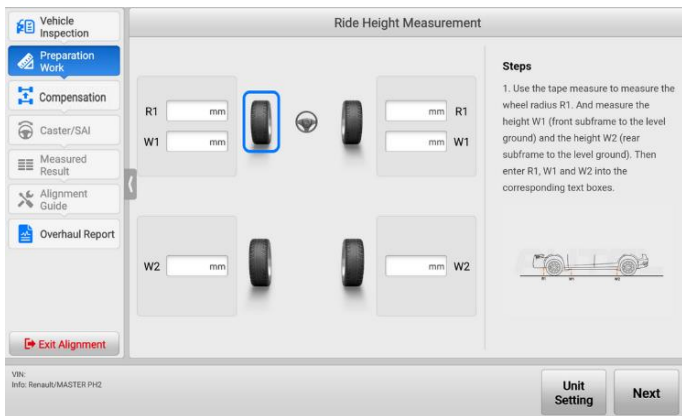

Figure 4-31 Measure Ride Height with Tape 2

2. Measure with ride height target

The ride height can be measured with ride height target if one of the following conditions is met:

- a) There is a standard value for the ride height, and the ride height is measured from the lower edge of wheel trim to the center of wheel rim.

- b) BMW vehicles which the ride height is measured from the lower edge of the wheel trim to the lower edge of wheel rim, and the rim size is selected before entering the whole wheel alignment procedures screen.

NOTE

- A dedicated ride height target to measure the ride height is required, which can be purchased by contacting the local dealer or manufacturer.
- After measuring the ride height, be careful to remove the ride height target, so as to avoid vehicle body damage.

➤ **To install a ride height target for ride height measurement**

1. Follow the guide shown on the screen, install the wheel clamps (rim clamps), wheel targets and ride height targets after ensuring the distance between the calibration frame and the front wheel center is within 2.03 - 3.30 m (7.23 - 10.83 ft).

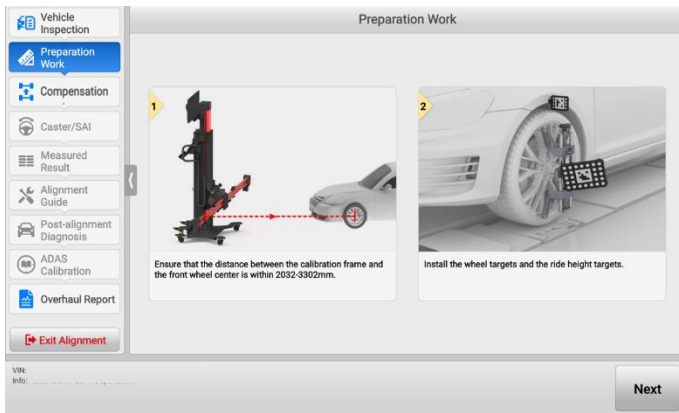

Figure 4-32 Install Ride Height Target

2. Tap **Next** to enter the following screen. The crossbar height will be automatically adjusted to search the targets. The ride height value will automatically display in the corresponding input box.

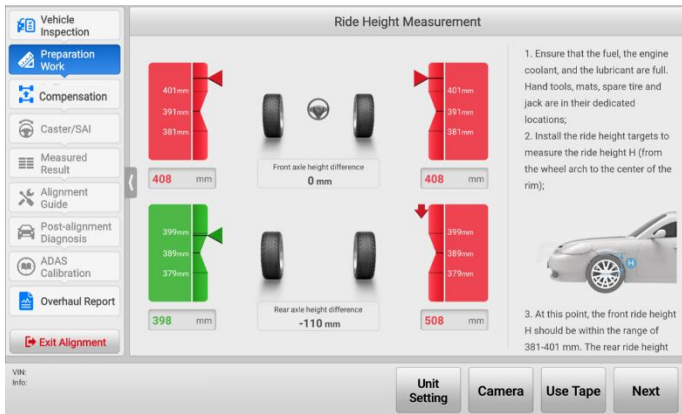

Figure 4-33 Measure Ride Height with Ride Height Target

3. Indicated by Tilt Angles

For some vehicles, such as Mercedes-Benz, the ride height is indicated by the tilt angles.

- a) Use the Inclination Sensor (for Mercedes-Benz) to measure the tilt angles of the corresponding chassis components, and enter the tilt angles into the corresponding input box.

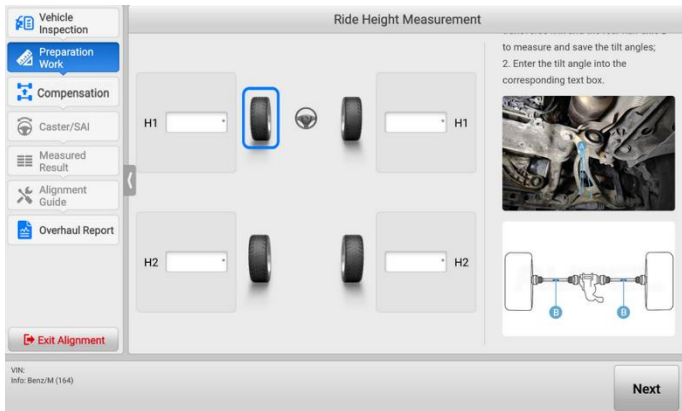

Figure 4-34 Measure and Input Tilt Angles

4.5.3 Compensation

This function is mainly used to compensate for errors caused when installing tools such as the wheel clamp (rim clamp/tire clamp), and target.

NOTE

- If the wheel clamp (rim clamp/tire clamp), or target is removed or loosened during compensation, it will result in inaccurate measurement results. In this case, you need to perform the compensation again.
- Do not obstruct the target during the compensation.

4.5.3.1 Rolling Compensation

1. Follow the guides shown on the tablet to complete the following preparations:
 - Insert turnplate/slip plate pins and install turnplate bridge.
 - Drive the vehicle on the alignment tack and place the wheel chocks to prevent movement.
 - Steer ahead, lock steering wheel, place transmission in neutral, release parking brake.
 - Install the wheel clamps (rim clamps) and targets (if not previously installed).

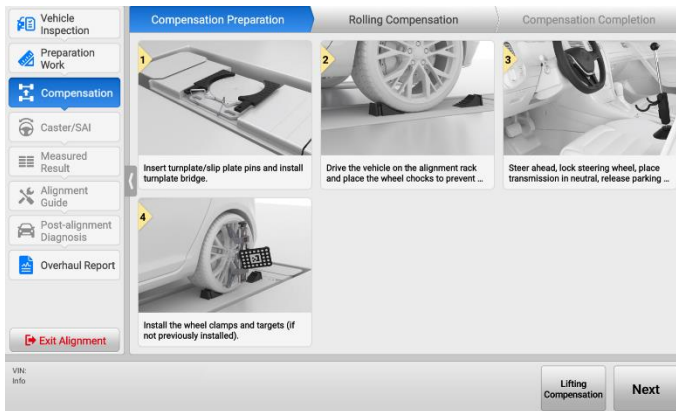

Figure 4-35 Rolling Compensation Preparations (Use Rim Clamp)

NOTE

1. When driving the vehicle onto the lift, the width from the turntable bridge to each wheel should be the same, and the front wheel of the vehicle should stop at the center of the turntable.
2. To install wheel clamp (rim clamp) and target on wheel, see [Target](#).

2. If the above preparations are completed, then tap **Next**. The crossbar height will be adjusted automatically to search the targets, and the tablet will enter the following screen.

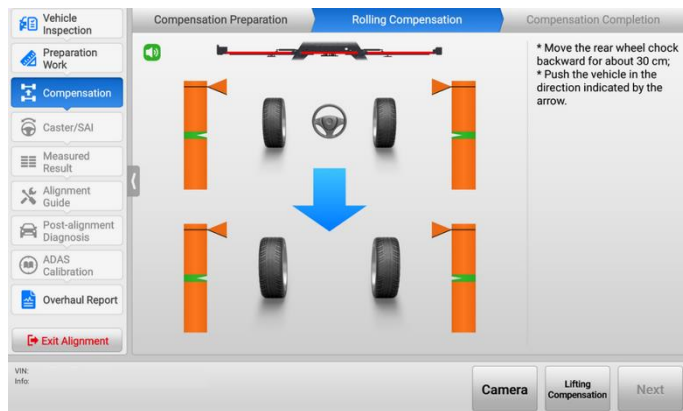

Figure 4-36 Start Rolling Compensation 1 (Use Rim Clamp)

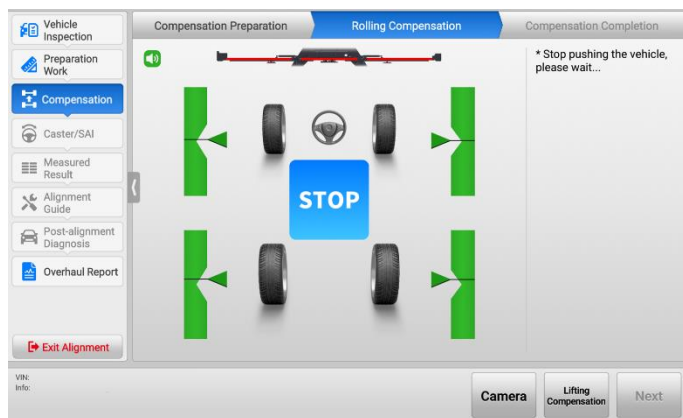

Figure 4-37 Start Rolling Compensation 2 (Use Rim Clamp)

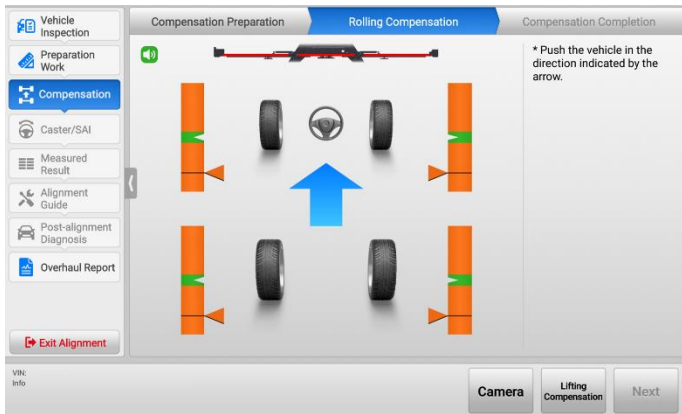

Figure 4-38 Start Rolling Compensation 3 (Use Rim Clamp)

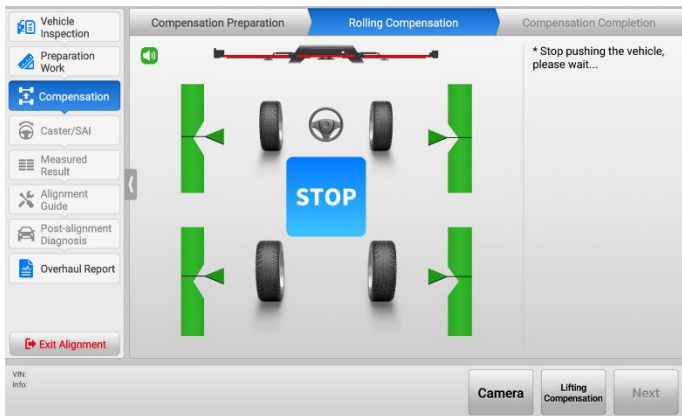

Figure 4-39 Start Rolling Compensation 4 (Use Rim Clamp)

3. Follow the guides above shown on the tablet, push the vehicle backward and forward to complete compensation.

NOTE

Do not touch the wheel clamps and targets when pushing the vehicle.

4. After the compensation is completed, the tablet will enter the next screen automatically. Follow the illustration shown on the tablet to place wheel chocks in the front and rear of the wheel to prevent wheel movement.

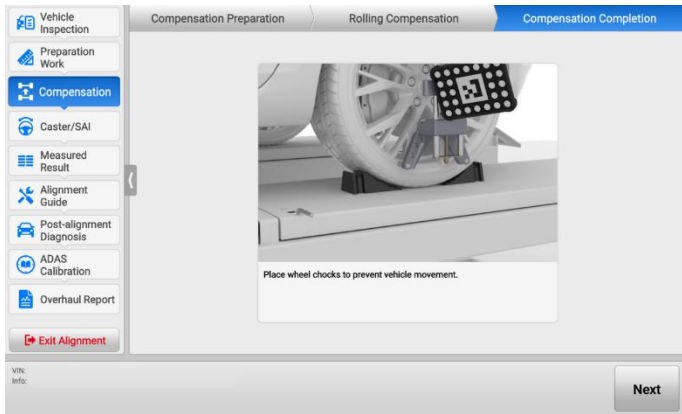

Figure 4-40 Complete Rolling Compensation (Use Rim Clamp)

4.5.3.2 Lifting Compensation

1. Follow the guides shown on the tablet to complete the preparations:
 - Steer ahead, lock steering wheel, place transmission in neutral, release parking brake.
 - Raise the vehicle.
 - Install the wheel clamps (rim clamps) and targets (if not previously installed).

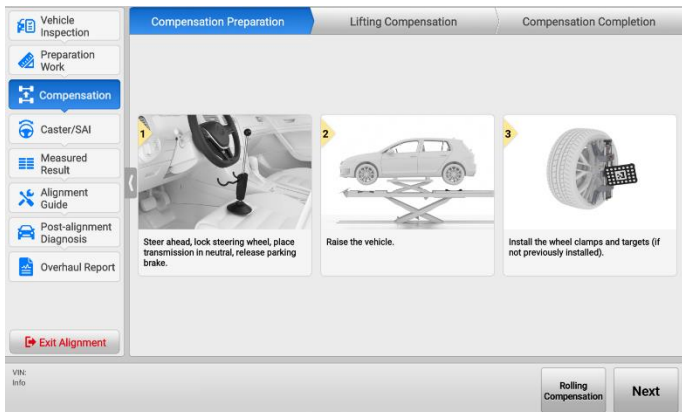

Figure 4-41 Lifting Compensation Preparation (Use Rim Clamp)

2. If the above preparations are completed, then tap **Next**. The crossbar height will be adjusted automatically to search the targets, and the tablet will enter the following screen.

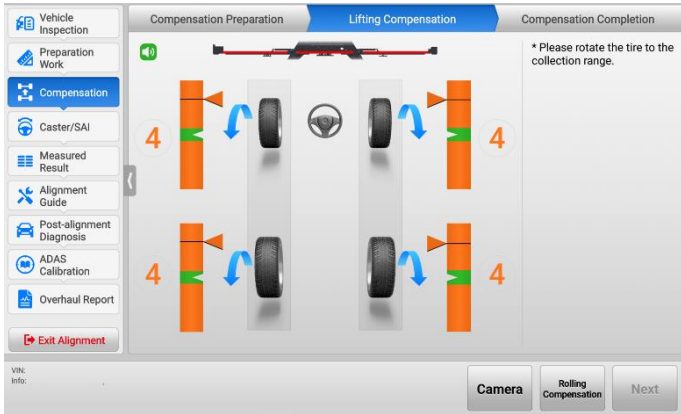

Figure 4-42 Start Lifting Compensation 1 (Use Rim Clamp)

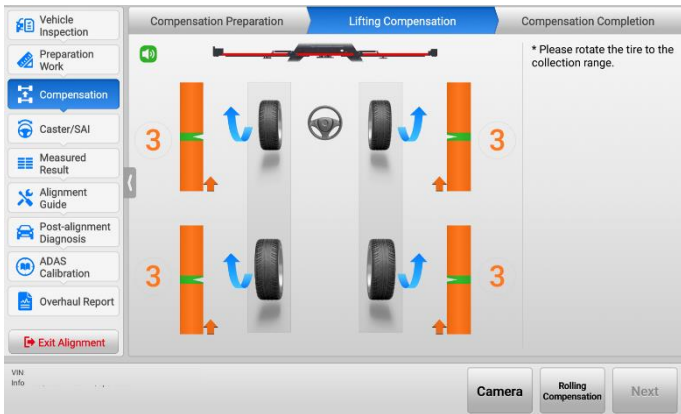

Figure 4-43 Start Lifting Compensation 2 (Use Rim Clamp)

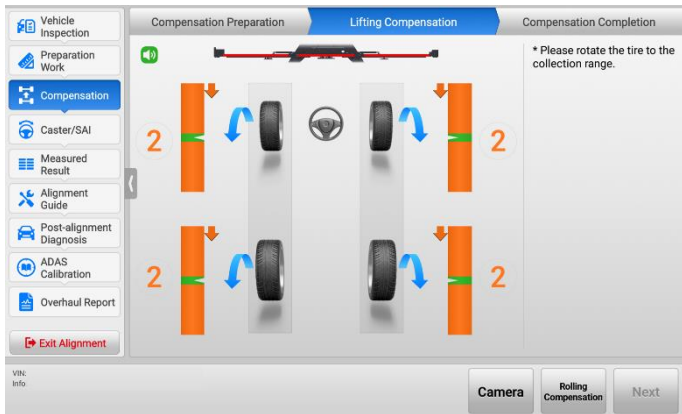

Figure 4-44 Start Lifting Compensation 3 (Use Rim Clamp)

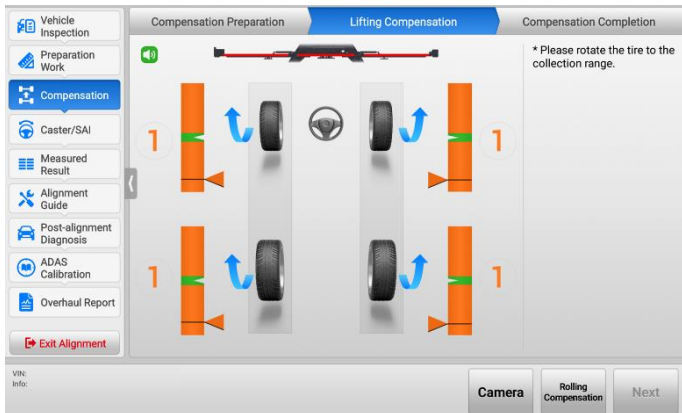

Figure 4-45 Start Lifting Compensation 4 (Use Rim Clamp)

3. Follow the guides above shown on the tablet, rotate the tire to the collection range, and then stop.
4. After the collection is completed, the tablet will enter the following screen automatically. Follow the guides shown on the tablet to complete the following operations:
 - Remove turnplate/slip plate pins and remove turnplate bridge.
 - Lower the wheels and jounce the vehicle.
 - Place wheel chocks to prevent vehicle movement.

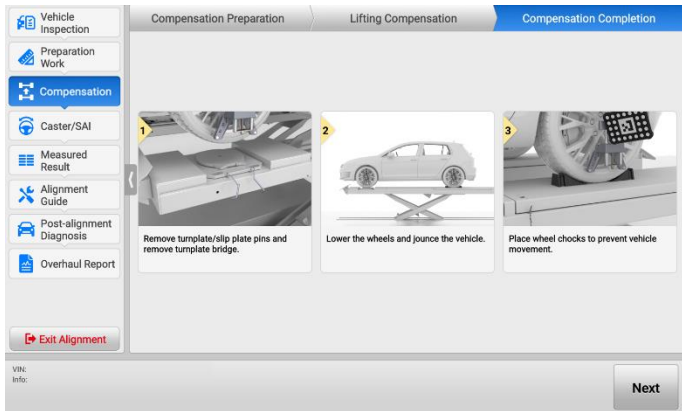

Figure 4-46 Complete Lifting Compensation (Use Rim Clamp)

NOTE

- Make sure the four targets installed on wheels are level before lowering the vehicle. If the targets are not level, the subsequent measured results and wheel alignment results may be affected.
- Before lowering the vehicle, the turnplate, slip plate pins, and turnplate bridge must be removed. Otherwise, the measurement results may be inaccurate due to the unnatural force on the vehicle.
- Before lowering the vehicle, please shake the vehicle so that the components of the chassis are evenly stressed.

4.5.4 Caster/SAI/IA Angle Measurement

This function provides the guidance for measuring the Caster angle, SAI (Steering Axis Inclination) angle, IA (Included Angle) angle, toe-out on turns, and maximum steering angle. Measuring these angles can help in determining front suspension or steering system problems with a vehicle.

4.5.4.1 Select Measurement Angle

- a) The Caster angle, SAI angle and IA angle are selected for measurement by default, for these angles must be measured.
- b) If the toe-out on turns is selected for measurement, the Caster angle, SAI angle, IA angle, and toe-out on turns will be measured together.
- c) If the maximum steering angle is selected for measurement, the Caster angle, SAI angle, IA angle, and maximum steering angle will be measured together.

- d) If the toe-out on turns and the maximum steering angle are selected for measurement at the same time, the Caster angle, SAI angle, IA angle, toe-out on turns, and maximum steering angle will be measured together.

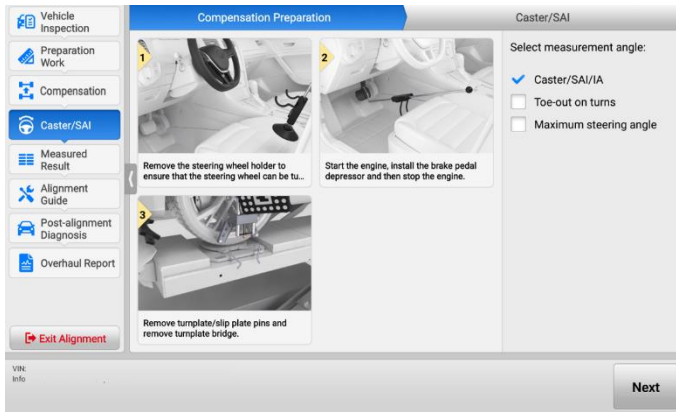

Figure 4-47 Caster/SAI/IA Measurement

4.5.4.2 Angle Measurement Preparation

Follow the guides shown on the tablet to complete the following operations:

1. Remove the steering wheel holder to ensure that the steering wheel can be turned.
2. Start the engine, install the brake pedal depressor and then stop the engine.
3. Remove turnplate/slip plate pins and remove turntable bridge.
4. Install maximum steering angle target on front wheels (This operation is required only when the maximum steering angle needs to be measured).

NOTE

- If the brake pedal depressor is installed without starting the vehicle, inaccurate measurement results may be caused by the fact that the brakes are not locked.
- The measured results of toe-out on turns and maximum steering angle will be displayed on the Result Lists in Measured Result section.

4.5.4.3 Start Angle Measurement

After the above preparations are successfully made, tap **Next** to start angle measurement. Then follow the guides shown on the tablet, turn the steering wheel left or right to the collection range step by step. Once the measurement procedures are completed, it will enter the Measured Result section automatically.

4.5.5 Measured Result

This section helps in:

1. Viewing the measured results about toe, camber, caster, symmetry value, rolling angle, and so on.
2. Viewing and changing the wheel specifications.

4.5.5.1 Graphical Result



Figure 4-48 Measured Result Screen (Graphical Result)

- a) Tap the single image on the screen, the selected image will be zoomed in. See as follows.

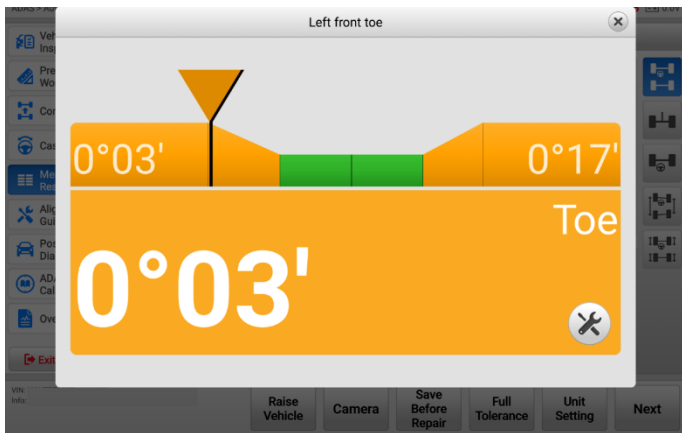





Figure 4-49 Zoom-in Image

- b) Tap the  button on the above screen to open the adjustment guide screen, the adjustment guide about the image of the selected image will be displayed, you can follow the guides on the screen to adjust. If the adjustment is completed, tap  to exit the adjustment guide screen.
- c) Tap the buttons like  in the middle part of the screen to view the Parameter Descriptions, which are introduced in [Glossary](#).
- d) Tap the buttons like  in the right of the screen, you can view the Graphical Result-Rear, the Graphical Result-Front, the Graphical Result-Symmetry Value, and the Graphical Result-Rolling Diameter, respectively.
- e) Tap the **Raise Vehicle** button to raise vehicle for adjustment. See [Raise Vehicle](#).
- f) Tap the **Camera** button, you can check the cameras' working condition.

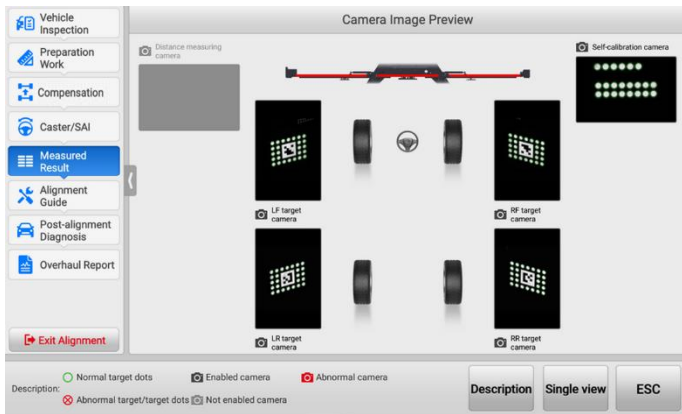







Figure 4-50 Camera Image Preview Screen

- The **Camera** button is always available when you need to check the cameras' working condition, not limited to this screen.
- Tap **Description** to check the explanations for each icon displayed on the screen. See [Table 4-4 Camera Descriptions](#) for details.
- Tap **Full view** or **Single view** to change the preview method for the camera image.
- Tap **ESC** to exit the Camera Image Preview screen.

Table 4-4 Camera Descriptions

Icon	Name	Explanation
	Normal Target Dots	Target dots can be recognized normally.
	Abnormal Target/Target Dots	The target is dirty or blocked, clean it or remove the obstructions.
	Enabled Camera	The camera works normally.
	Not Enabled Camera	The camera is not used by the current function.
	Abnormal Camera	<p>The diagnostic tool fails to communicate with the cameras. Follow the steps below:</p> <ol style="list-style-type: none"> 1. Check if the power is ON; 2. Check if the current camera connection is normal; 3. Check if the diagnostic tool is connected to the camera Wi-Fi; 4. Record and upload logs. Fill in the problem description in detail.

- g) Tap **Save Before Repair** to save the measurements before alignment. If the measurements before repair are already saved, the tablet will prompt you and ask if you want to overwrite it.
- h) Tap **Full Tolerance** or **Half Tolerance** to change the graphical display mode from Full Tolerance and Half Tolerance.
 - **Full Tolerance:** equals to OE specification's tolerance.
 - **Half Tolerance:** half of the OE specification's tolerance.
- i) Tap **Unit Setting** to change the units.
- j) Tap **Next** to enter Alignment Guide section. Be noted that if the measurements before repair are not saved, the tablet will ask you whether to save these specifications as measurements before repair.

4.5.5.2 Raise Vehicle

This function is suitable for vehicles that need to be lifted twice to adjust the wheel alignment parameters.

➤ To raise vehicle

1. Tap **Raise Vehicle** on the Measured Result screen.
2. Follow the guides shown on the tablet, you need to complete the following preparations before raising the vehicle:
 - 1) Set the steering wheel at center position. Lock the steering wheel.
 - 2) Start the engine, install the brake pedal depressor and then stop the engine.

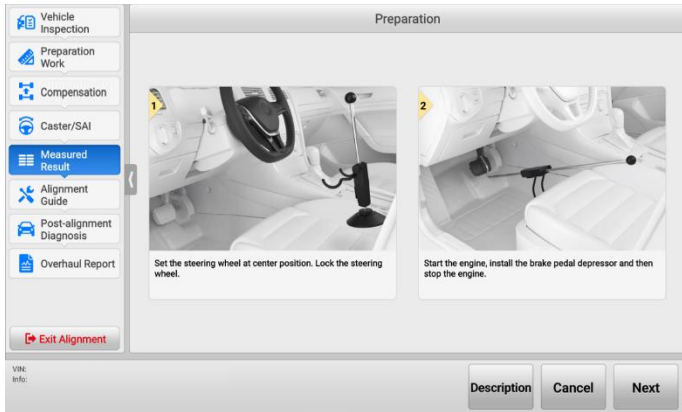

Figure 4-51 Raise Vehicle Preparations

3. Tap **Next** after the above preparations are completed, the tablet will start collecting data. In the process of collecting data, do not obstruct the targets. After the data is successfully collected, the tablet will enter the following screen. Follow the guide shown on the tablet, raise the vehicle and lock the lift.

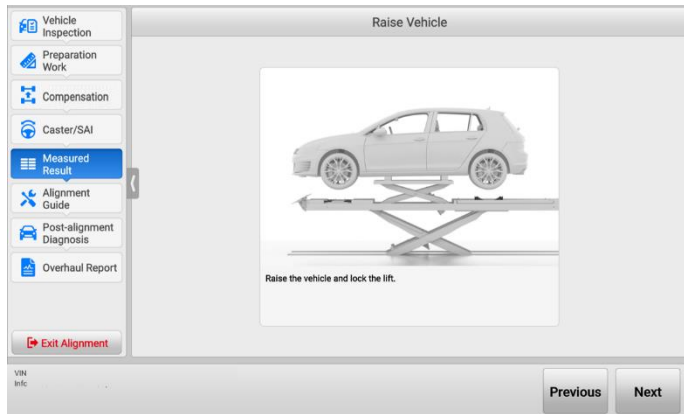

Figure 4-52 Raise Vehicle

4. After the vehicle is raised and the lift is locked, tap **Next** to collect data. After the data is collected, the tablet will return to Measured Result screen. Follow the guides on the Measured Result to perform adjustment.

➤ **To lower vehicle**

After raising the vehicle, the **Raise Vehicle** button on Measured Result screen will switch to **Lower Vehicle**.

1. Tap the **Lower Vehicle** button on the Measured Result screen.
2. You can lower the vehicle as shown in the guides on the screen.
 - 1) Remove turnplate/slip plate pins and remove turnplate bridge.
 - 2) Lower the wheels and jounce the vehicle.
 - 3) Place wheel chocks to prevent vehicle movement.

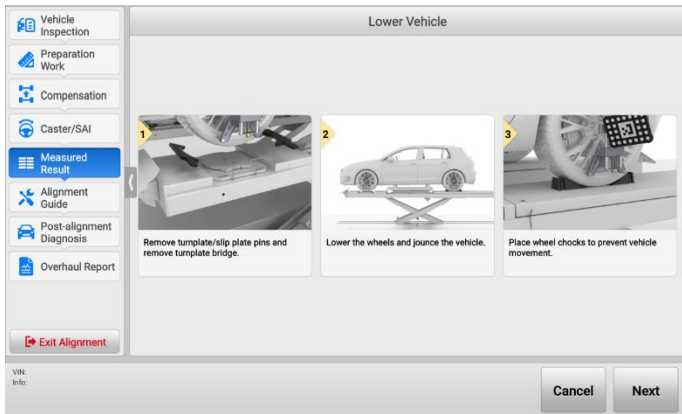

Figure 4-53 Lower Vehicle

3. After lowering the vehicle, tap **Next**, the tablet will return to Measured Result screen.

4.5.5.3 Results List

The whole before repair results can also be displayed at a list, which look like the following illustration. You can save the list before alignment. The operations of the buttons in the Results list are same as those in Graphical Results screen.

	Graphical Result		Results List	
	Left	Right	Front axle	Measured
Front axle				
Toe	0°03'	0°02'	Total toe	0°05'
Camber	-0°04'	0°01'	Cross camber	-0°05'
Caster	4°29'	3°31'	Cross caster	0°58'
SAI	-2°52'	3°19'	Cross SAI	-6°11'
IA	-2°56'	3°20'	Set back	0°01'
Toe-out on turns			Wheels straight ahead	0°01'
Left maximum steer	-34°59'	35°22'	--	--
Right maximum steer	34°41'	-34°22'	--	--
Ride Height	408mm	408mm	--	--
Rear axle	Left	Right	Rear axle	Measured
Toe	-1°53'	1°52'	Total toe	-0°01'

VIN Info: Camera Save Before Repair Full Tolerance Unit Setting Next

Figure 4-54 Measured Result Screen (Results List)

4.5.6 Alignment Guide

In Alignment Guide section, the detailed alignment procedures with illustrations on the screen make the adjustment of wheel specifications more convenient and faster. In order to better guide users to operate, the alignment guide for some vehicle models includes adjustment animation.

NOTE

1. When adjusting front toe, some vehicle models have both Normal Mode and Guide Mode. The Guide Mode is used by default. If you want to change the mode, tap **Normal Mode** or **Guide Mode** to switch.
2. To reduce the influence on front caster caused by the adjustment of other specifications, the caster angle needs to be remeasured before adjusting front caster.

4.5.6.1 Alignment Procedures

According to the OE process requirements, the detailed and complete alignment procedures will be provided to guide you to adjust the wheel specifications.

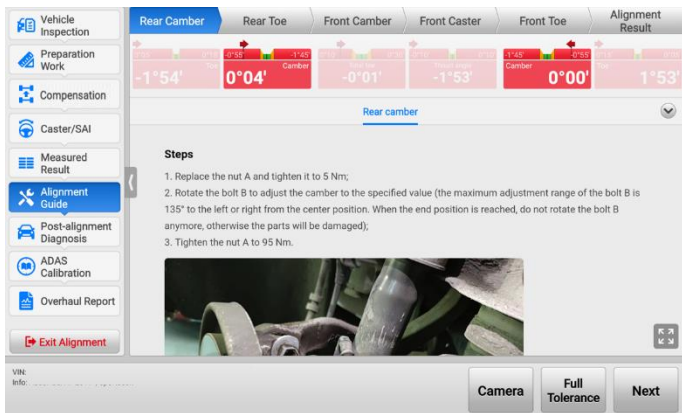

Figure 4-55 Parameters Adjustment Procedures Screen 1

- a) Follow the order on the top of the main section of the screen to complete all the adjustment procedures of wheel alignment parameters. The adjustment order is quite important, if the wheel alignment parameters are not adjusted according to the order (Rear Camber -> Rear Toe -> Front Caster -> Front Toe -> Alignment Result) displayed on the top of the main section, it may result in repeat operations.
- b) Check the highlighted red images on the screen, and adjust as shown in the screen guides. If the parameters of the angle are adjusted to correct values, the highlighted red images will turn highlighted green images. Then tap **Next** to adjust other parameters in the same way.

- c) For some wheel specifications, the OE process does not give an adjustment method. The tablet will display as below.

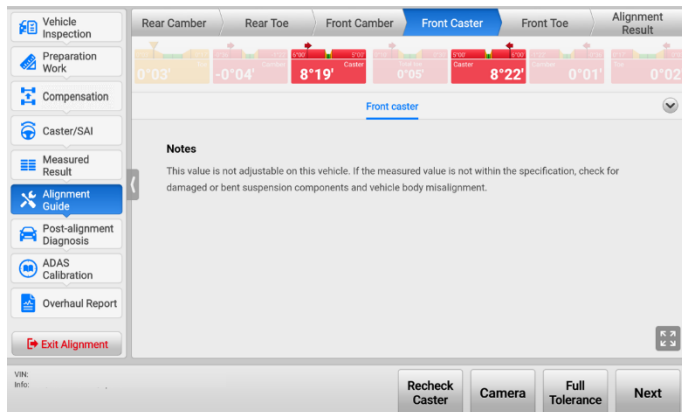

Figure 4-56 Parameters Adjustment Procedures Screen 2

- d) After completing all the wheel specifications adjustment procedures, tap **Next** to enter Alignment Result screen, check the image color (representing adjustment results) and make sure all the images are green. Otherwise, it needs to be readjusted.



Figure 4-57 Alignment Result Screen

4.5.6.2 Guide Mode on Front Toe

For some vehicle models, there are two modes to guide you to adjust front toe, namely Guide Mode and Normal Mode. The Guide Mode helps you to achieve the purpose of adjusting the front toe by the left and right tie rod, much easier and quicker, so the Guide Mode is used by default.

In Guide Mode, there are four steps for adjusting the Front Toe: preparation, adjust right tie rod, adjust left tie rod, and center steering.

1. Follow the guides shown on the tablet, complete the following preparations:
 - 1) Set the steering wheel at center position (A steering wheel level is recommended).
 - 2) Start the engine, install the brake pedal depressor and then stop the engine.

NOTE

If the brake pedal depressor is installed without starting the vehicle, inaccurate measurement results may be caused by the fact that the brakes are not locked.

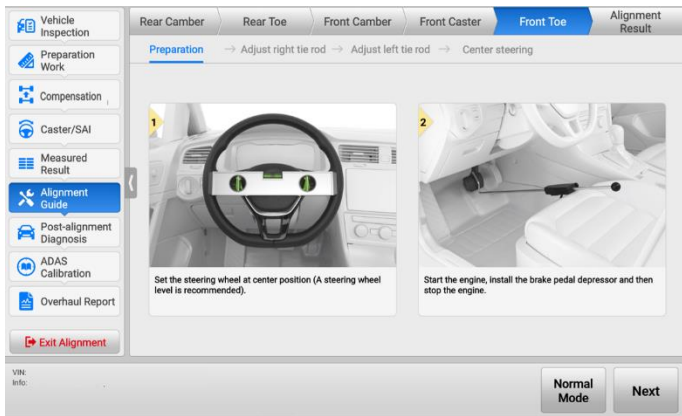

Figure 4-58 Front Toe Adjustment Preparation

2. After the above preparations are completed, tap **Next** to collect data and adjust right tie rod as shown in the guides on the screen.
 - 1) Loosen the lock nut and adjust the right tie rod to the tolerance range.
 - 2) Jounce the front part of the vehicle to set all bottom components in natural status.
 - 3) Tighten the lock nut.

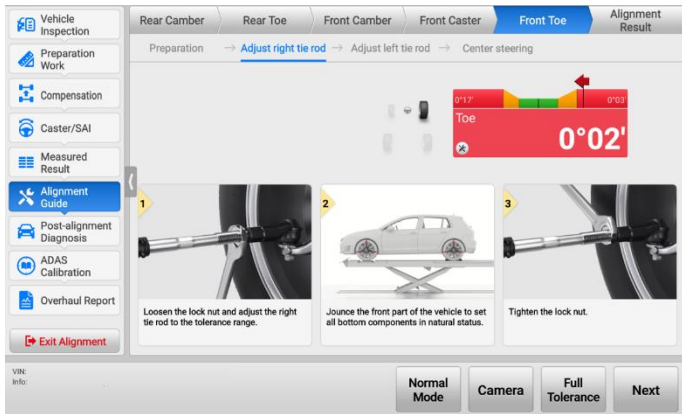

Figure 4-59 Adjust Right Tie Rod

3. If the right tie rod is adjusted well, tap **Next** to collect data and then enter left tie rod adjustment guide screen.
 - 1) Loosen the lock nut and adjust the left tie rod to the tolerance range.
 - 2) Jounce the front part of the vehicle to set all bottom components in natural status.
 - 3) Tighten the lock nut.

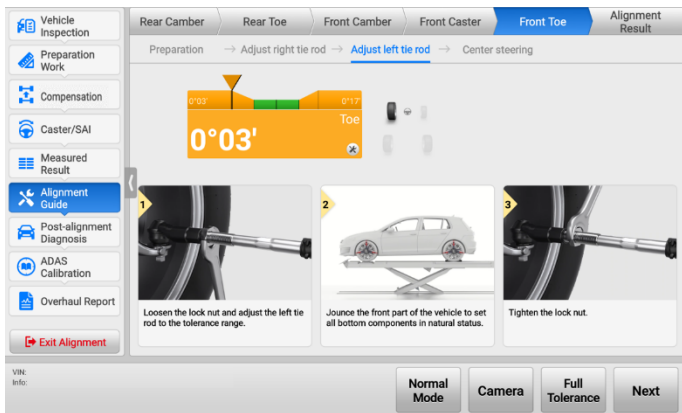

Figure 4-60 Adjust Left Tie Rod

4. After the left tie rod is well adjusted, tap **Next** to enter the center steering guide screen. Follow the guide shown on the tablet, set wheels straight ahead. If steering wheel is not centered, tap **Readjust** to adjust the front toe again.

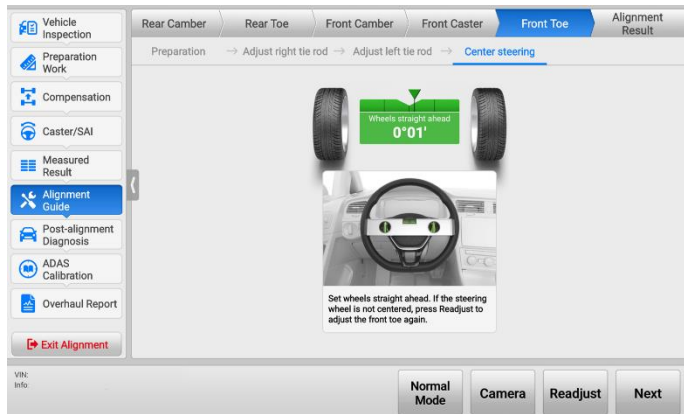

Figure 4-61 Center Steering

4.5.6.3 Recheck Caster

In some OE manuals, you need to recheck the caster angle after adjusting the front caster, so that the caster angle is within the standard range. When rechecking the caster, be noted that the crossbar and the vehicle should not be raised or lowered.

➤ To recheck caster

1. Tap the **Recheck Caster** button on Front Caster screen. Follow the guides shown on the tablet, complete the following operations:
 - 1) Remove the steering wheel holder stand tool to ensure that the steering wheel can be turned.
 - 2) Start the engine, install the brake pedal depressor and then stop the engine.
 - 3) Remove turnplate/slip plate pins and remove turnplate bridge.

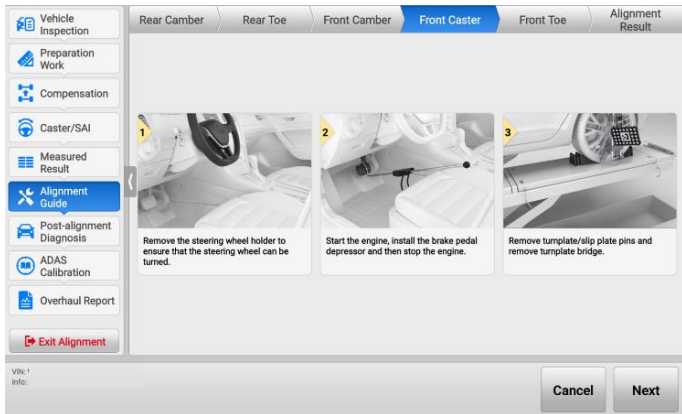

Figure 4-62 Recheck Caster Preparations

2. After completing the above preparations, tap **Next** to enter the next screen.
3. Follow the illustration guides shown on the tablet, turn the steering wheel left or right to the collection range. If the steering wheel is centered, stop turning the steering wheel, the tablet will return to Front Caster screen automatically.



Figure 4-63 Steering Wheel Adjustment

4.5.7 Post-alignment Diagnosis

Some vehicles need to perform related diagnostic functions after the wheel alignment parameters are adjusted, such as SAS reset.

4.5.7.1 Steering Angle Sensor (SAS) Reset

After adjusting thrust angle and toe angle, SAS reset is required under some circumstances. Failure to perform a SAS reset may affect the functionality of security systems such as VSC, ESC, TCS, etc.

➤ To perform SAS reset

1. Follow the guides shown on the tablet to check if the following conditions are met:
 - 1) The brake pedal depressor is already removed.
 - 2) The ignition is ON.
 - 3) The engine is OFF.
 - 4) The VCI is connected properly.

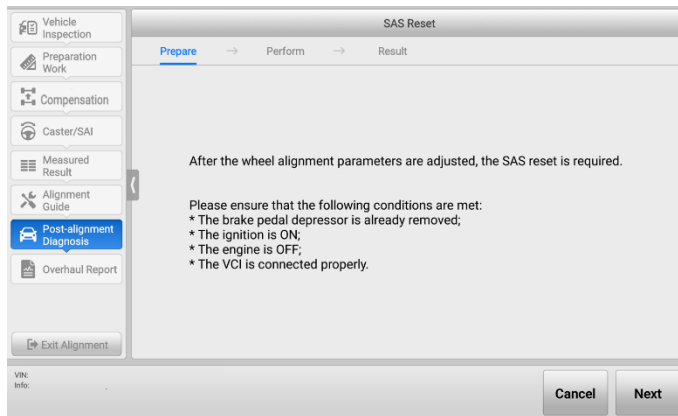

Figure 4-64 SAS Reset Screen 1

2. If the above conditions are met, tap **Next** to enter the next screen. And follow the screen guide, turn the steering wheel slowly to the center position, set the front wheels straight ahead, and release the steering wheel.

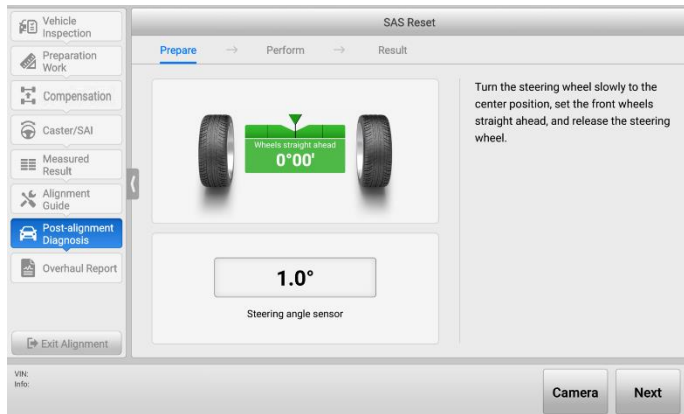

Figure 4-65 SAS Reset Screen 2

3. After that, tap **Next** to continue. Follow the on-screen instructions to turn the steering wheel to the right for about 30° and then perform the following steps:
 - 1) Turn the steering wheel slowly to the left end stop and hold for about 5 s;
 - 2) Turn the steering wheel slowly to the right end stop and hold for about 5 s;
 - 3) Turn the steering wheel slowly to the center position, set front wheels straight ahead, and release the steering wheel.

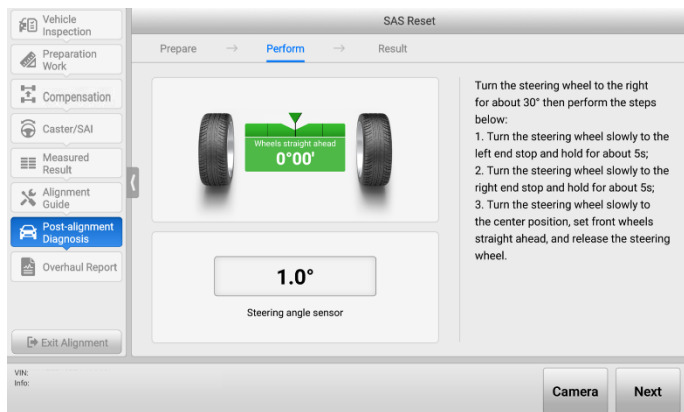



Figure 4-66 SAS Reset Screen 3

4. If the above operations are completed, tap **Next** to enter SAS reset result screen. If the screen displays , it indicates that the SAS reset is successful; if the screen displays , it indicates SAS reset has failed.

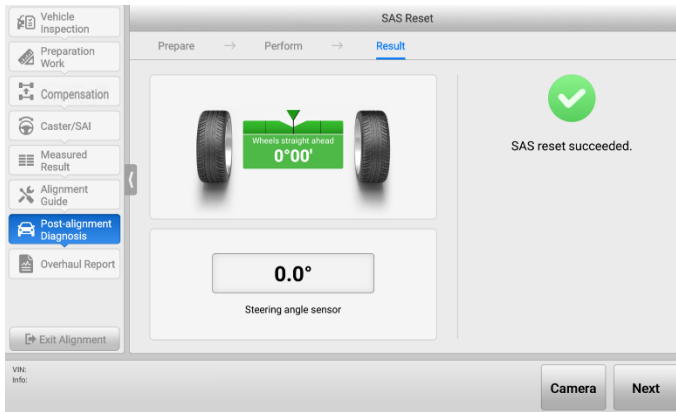

Figure 4-67 SAS Reset Screen 4

4.5.8 ADAS Calibration

After performing wheel alignment, to ensure the safety of vehicle driving, some ADAS functions need to be recalibrated.

The specific operations of ADAS calibration will be introduced in the later ADAS Calibration Function chapter. To know how to perform ADAS calibration, see [ADAS Calibration Function](#) for details.

4.5.9 Overhaul Report

In this section, after performing wheel alignment, you are able to:

- 1) Check the Wheel Alignment Report, the wheel alignment parameters, etc.
- 2) Save reports and share reports to cloud.

4.5.9.1 Fill in Customer Information

Before entering Overhaul Report, you need to complete customer information. See the customer information table as below, the items marked with * must fill in the corresponding information.

The screenshot shows a 'Customer information' dialog box with the following fields:

- Vehicle information:**
 - * License plate: Required
 - * VIN: WAUZZZ4G7EN1XXXXX
 - * Year: 2014 (E)
 - * Make: ADAS
 - * Model: Audi A7 2011>
 - * Odometer: Required miles
 - Color: (empty)
- Personal Info:**
 - Name: First name, Last name
 - Mobile: (empty)
 - Tel: (empty)
 - Email: (empty)
 - Company: (empty)
 - Address: (empty)
- Work Order Information:**
 - * Technician: h21313

Figure 4-68 Customer Information Table

4.5.9.2 Report Types

Eight reports can be seen if all the functions are enabled during the whole wheel alignment procedures, including Wheel Alignment Report, Pre-repair & Post-repair Report, Pre-repair Report, Current Values Report, Symmetry Value Report, Chassis Inspection Report, Tire Inspection Report, and Ride Height Report.

- 1) Wheel Alignment Report: All inspection results, including tread depth, tire pressure, rolling diameter, ride height, front axle specifications, and rear specifications.

NOTE

- The tread depth values and tire pressure values are available only when the tread depth & pressure inspection is performed.
 - The ride height values are available only when the ride height measurement is performed.
-

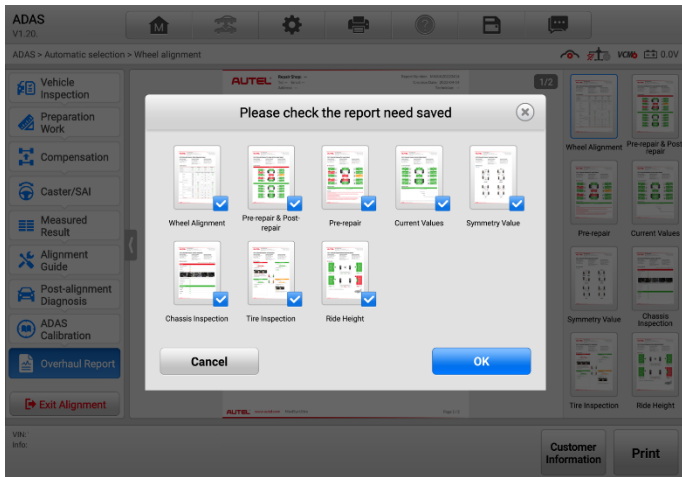

Figure 4-71 Save Report Screen 2

3. Tap **OK** after the reports that need to be saved are selected. If the tablet displays the following screen, it indicates that the reports are saved successfully.

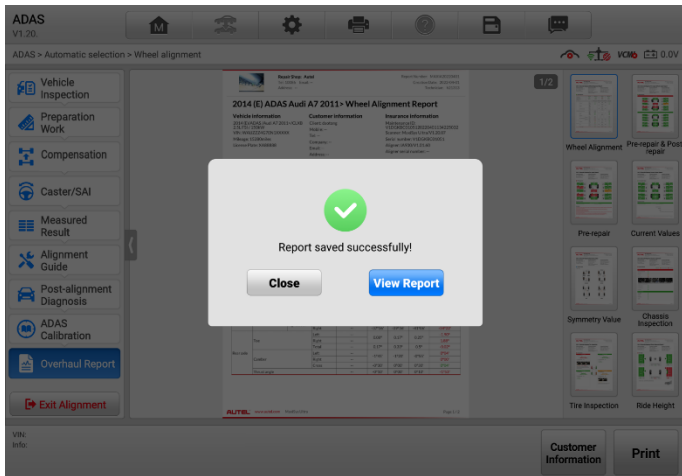

Figure 4-72 Save Report Screen 3

4.5.10.2 Report Cloud Sharing

1. Correct Directory Path

- 1) Tap **View Report** (see [Figure 4-72 Save Report Screen 3](#)) after saving the report successfully, or tap **Report** from **Data Manager** to enter Report List screen.

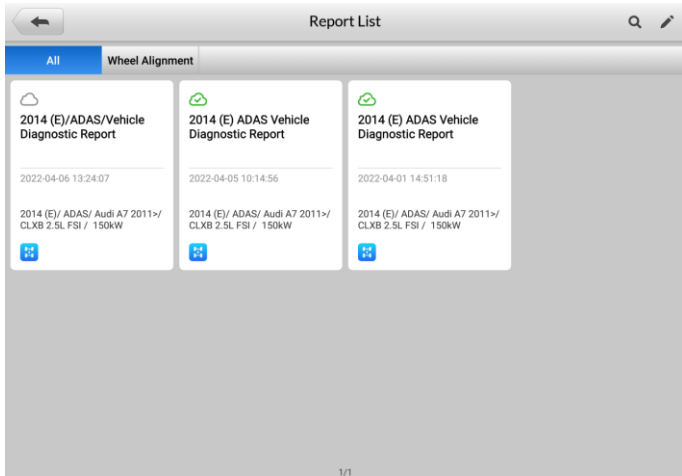



Figure 4-73 Report List Screen

- 2) In the Report List screen, if the report displays , which means the report has been uploaded to cloud successfully, you can share the report with others; if the report displays , it means the report is failed to upload to cloud, cannot share with others.
2. Report Upload to Cloud Methods
 - 1) You share the cloud report via QR code, SMS or email to customers in real time.
 3. Report Upload to Cloud Procedures
 - 1) Select the report that has been uploaded to cloud successfully in the Report List screen, the following screen will display.

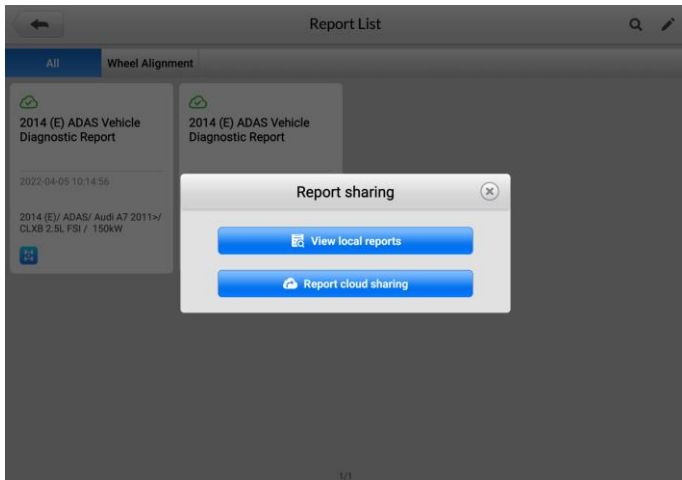

Figure 4-74 Report Cloud Sharing Screen 1

- 2) Tap **Report cloud sharing**, the following screen will display.

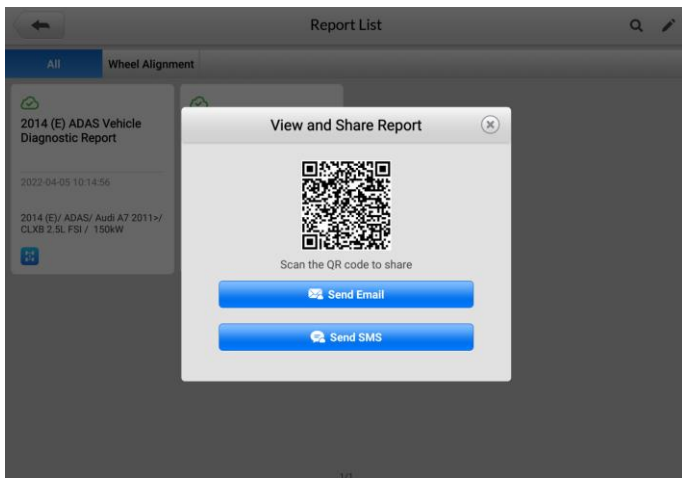

Figure 4-75 Report Cloud Sharing Method

- ✧ You can scan the QR to share the report directly. Be sure that the QR code for each report is different.



Figure 4-76 Report Cloud Sharing Method 1

- ✧ Or you can tap **Send Email** to display the following screen and enter the Email address, then tap **OK** for report sharing.

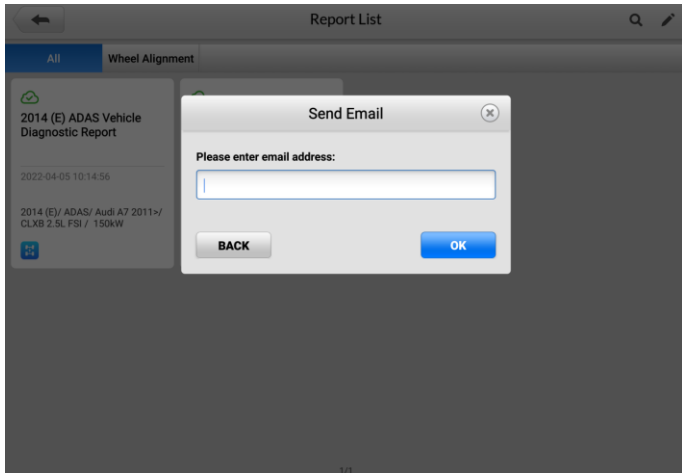

Figure 4-77 Report Cloud Sharing Method 2

- ✧ Or you can tap **Send SMS** to display the following screen and enter the phone number, then tap **OK** for report sharing.

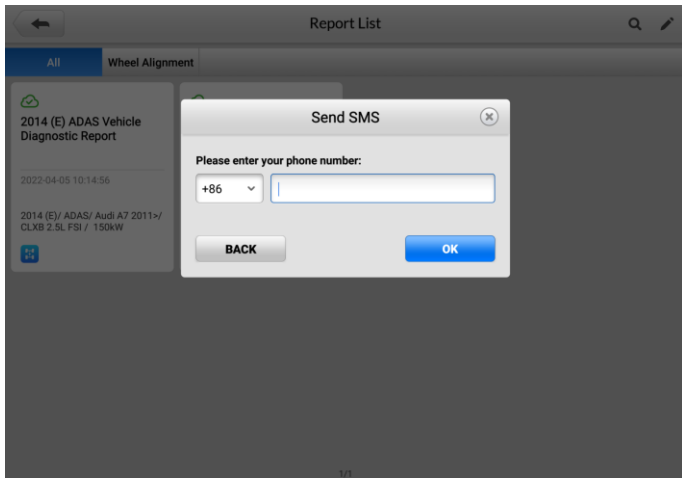
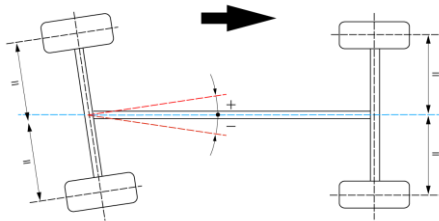

Figure 4-78 Report Cloud Sharing Screen 3

4.6 Glossary

4.6.1 Geometry Centerline

Refers to the intersection of the longitudinal center plane of the body and the horizontal plane of the front and rear axles (blue dotted line).



4.6.2 Thrust Angle

✧ Definition

The thrust angle is the angle between the longitudinal geometric center plane of the vehicle and the thrust line (the driving axis is the perpendicular line of the rear axle center). As shown in the picture below.

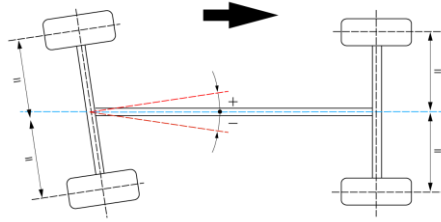

✧ Function

Ensure that the vehicle is driven straight ahead.

✧ Effects of abnormal thrust angle

- The steering wheel is tilted when the vehicle is driven straight ahead.
- The tires are abnormally worn and the vehicle pulls to one side.

4.6.3 Toe

✧ Definition

The toe is the angle between the center plane of the wheel rotation and the longitudinal plane of the vehicle (as shown in the picture below).

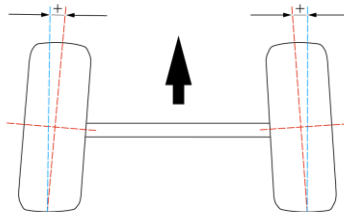

✧ Function

Eliminate or reduce the adverse effect when the front ends of the two wheels spread outward due to the camber in driving. Ensure that the wheels do not roll outwards. Prevent the wheels from sliding laterally. And reduce tire wear and fuel consumption.

✧ Effects of abnormal toe

- One side of the tire is abnormally worn.

- The vehicle has excessive vibrations when driving at high speed.
- The steering wheel is tilted when driving straight ahead.

4.6.4 Total Toe

The sum of the toe-in of the coaxial left and right wheels.

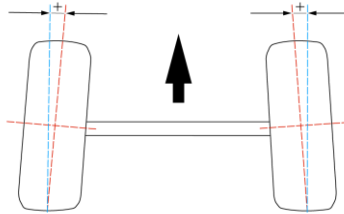

4.6.5 Camber

✧ Definition

The camber is the angle between the wheel rotation plane and the longitudinal plane perpendicular to the vehicle bearing plane. If the upper of the wheel is tilted outward relative to the rotation plane, it is the positive camber. If the upper of the wheel is tilted inward, it is the negative camber (as shown in the picture below).

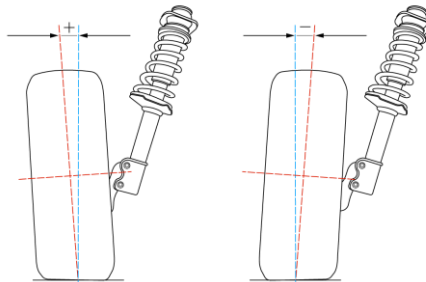

✧ Function

Improve the safety of the front wheels and make the steering lighter when driving.

✧ Effects of abnormal camber

- When the camber is too large, the outer side of the wheel is worn. The vehicle has excessive vibrations and the steering wheel is unstable when driving at high speed.

- When the camber is too small, the inner side of the wheel is worn. The steering is heavy and there is not enough force to return the steering wheel automatically to the center position.
- When the left camber and the right camber are not equal, the vehicle slides laterally and deviates when driving.

4.6.6 Front Caster

✧ Definition

The kingpin is the center of rotation when the wheel is turning. The caster is the angle between the kingpin axis and the perpendicular line of the vehicle bearing plane (as shown in the picture below).

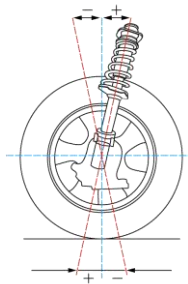

✧ Function

Create the force to return the steering wheel automatically to the center position. Ensure the vehicle stability when driving straight ahead. And make the steering wheel lighter and easier to return after the vehicle changes direction.

✧ Effects of abnormal caster

- When the left caster and the right caster are not equal, the left wheels are not synchronized with the right wheels when the vehicle changes direction. And, the vehicle deviates when driving.
- When the caster is too small, the steering wheel is unstable.
- When the caster is too large, the steering is heavy.

4.6.7 Steering Axis Inclination (SAI)

◇ Definition

The steering axis inclination is the angle between the kingpin axis and vertical line in the lateral vertical plane of the vehicle (as shown in the picture below).

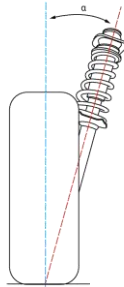

◇ Function

When the wheels deviate from the straight ahead position due to external force, the front wheels will automatically return to the straight ahead position.

◇ Effects of abnormal steering axis inclination

- When the steering axis inclination is too large, the required steering force becomes larger and the steering becomes difficult.
- When the steering axis inclination is too small, the steering system cannot fully return to the center position after the vehicle makes a turn.
- When the left steering axis inclination and the right steering axis inclination are not equal, the vehicle may pull to one side.

4.6.8 Included Angle (IA)

◇ Definition

The included angle is the angle γ between the kingpin axis and the wheel axis. The value of the included angle is the sum of the steering axis inclination α and the camber β (as shown in the picture below).

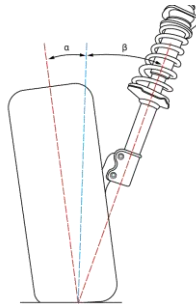

✧ Function

The included angle is used for diagnosing the suspension system misalignment and the suspension components deformation.

✧ Effects of abnormal included angle

- When the included angle is too small, the steering axis inclination is normal and the camber is too small, the shaft journal may be bent.
- When the included angle is normal, the steering axis inclination is too small and the camber is too large, the lower control arm may be bent.
- When the included angle is normal, the steering axis inclination is too large and the camber is too small, the upper control arm may be bent.
- When the included angle is too large, the steering axis inclination is too small and the camber is too large, the lower control arm and the shaft journal may be bent.

4.6.9 Toe-out on Turns

✧ Definition

The Ackerman angle is the difference between the outer wheel steering angle and the inner wheel steering angle when the vehicle makes a turn.

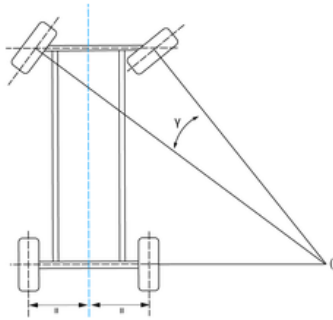

✧ Function

Ensure that the two front wheels point to the correct direction for more grip.

✧ Effects of abnormal Ackerman angle

- The tires may have feathering condition.
- The tires may slide laterally or jump or have abnormal noise due to insufficient grip when the vehicle makes a turn.

4.6.10 Maximum Steering Angle

✧ Definition

The maximum steering angle is the angle that the wheel rotation plane covers when the front wheels turn from the straight-ahead position to the left or right limit position.

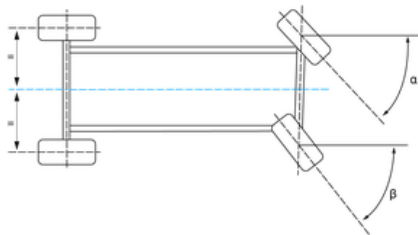

✧ Function

Control the minimum turning radius and ensure the vehicle driving stability and maneuverability.

✧ Effects of abnormal maximum steering angle

- The vehicle may slide during driving.
- There may be noise when the vehicle makes a turn.

- The steering wheel may shake.
- The steering is heavy.
- In extreme cases, the vehicle may roll over.

4.6.11 Ride Height

The location and method of ride height vary by vehicle manufacturer. See below for details.

- Ride height of vehicle manufacturers such as Volkswagen, Audi, Porsche, etc.

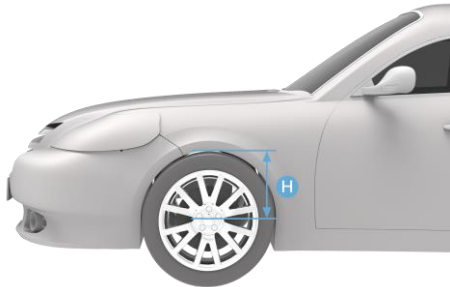

- Ride height of vehicle manufacturers such as BMW.

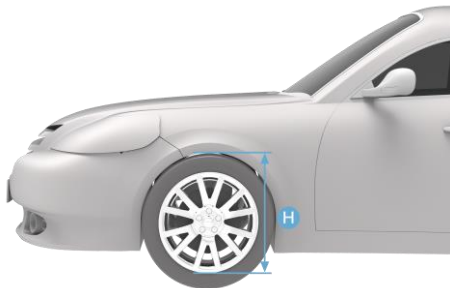

- Ride height of vehicle manufacturers such as Mercedes-Benz, Maybach, and etc., determined by measuring the inclination of chassis-related components.

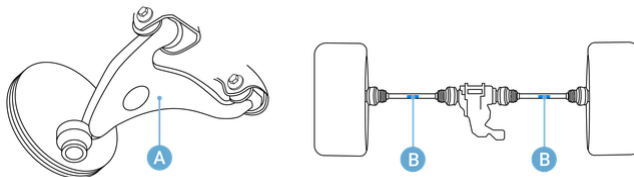

- Ride height of vehicle manufacturers such as Renault, Peugeot, more than one value that needs to be measured on one tire position.



4.6.12 Setback Angle

- ◇ Definition

The setback angle is the angle between the vertical line of the wheel center connecting line and the thrust line.

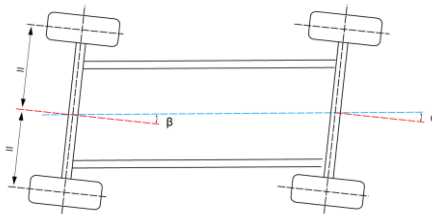

- ◇ Function

To diagnose the axle deformation.

- ◇ Effects of abnormal setback angle

- The setback angle leads to the difference between the left and right wheelbases, and the vehicle pulls to the side of shorter wheelbase.

4.6.13 Wheel Straight Ahead

Half of the difference value of front wheel left toe minus right toe.

4.6.14 Symmetrical Value

The geometric dimensions of the vehicle are usually symmetrical, which is used to preliminarily judge whether the vehicle has had an accident and the health status of the chassis, and assist the four-wheel alignment.

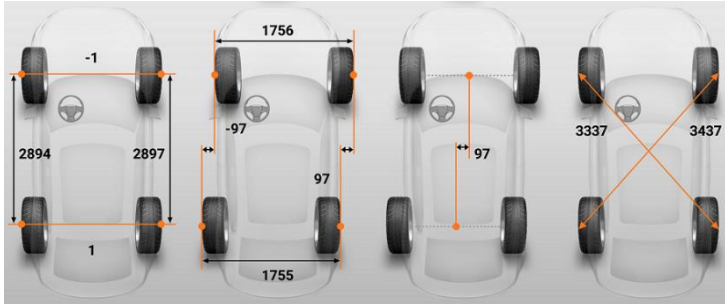

4.6.15 Rolling Diameter

The rolling radius R is equal to the distance from the center of the wheel to the ground. The rolling diameter is equivalent to two rolling radius R .

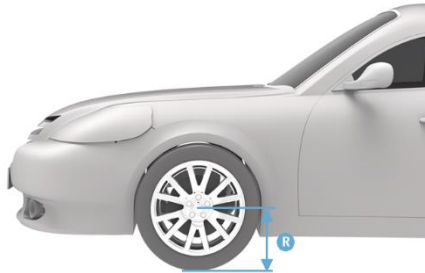

4.7 Perform Diagnostic Function & ADAS Calibration

4.7.1 Before Wheel Alignment

Some vehicles with air suspension require performing diagnostic function before performing wheel alignment. Only when the vehicle is set to the standard height, the wheel alignment parameters be accurately measured and adjusted.

4.7.2 After Wheel Alignment

Many vehicles need to perform diagnostic functions (e.g steering angle sensor calibration, set power steering gear) after wheel alignment if the toe is changed. Vehicles with ADAS systems such as front cameras need to calibrate the relevant ADAS systems.

5 Aligner & ADAS Settings

Before you perform wheel alignment & ADAS calibration function. Some settings like software activation, Wi-Fi connection, aligner calibration, wheel clamp and target calibration, inclination sensor calibration, need to be performed.

5.1 Common Settings

Common settings include Unit Settings, Select Clamp Type, Connect Tread Measuring Tool, Select Height Measuring Tool, Benz Chassis Level Measuring Tool, and Beep Setting.

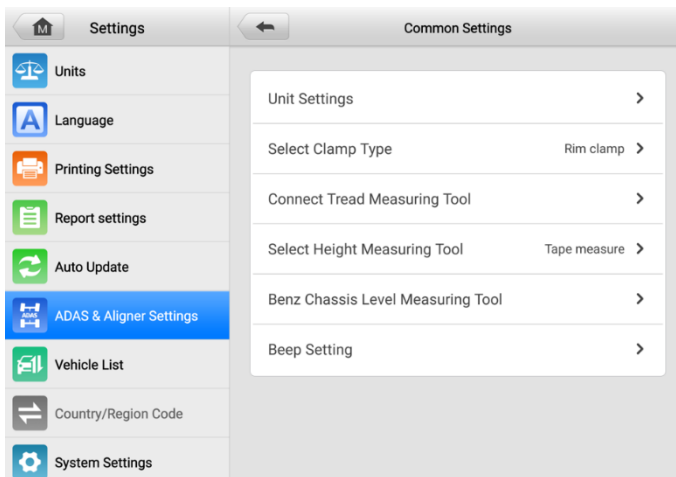

Figure 5-1 Common Settings Screen

5.1.1 Unit Settings

In Unit Settings, you can change the display format and unit of the standard values and measured values.

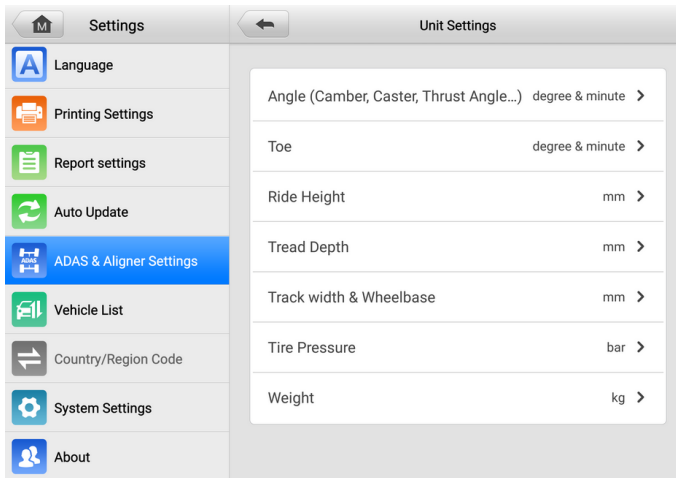

Figure 5-2 Unit Settings Screen

5.1.2 Select Clamp Type

Select the clamp type (rim clamp or tire clamp) for performing compensation:

- 1) When you select **Rim clamp**, the tablet will guide you to perform wheel alignment or ADAS calibration function by using rim clamp.
- 2) When you select **Tire clamp**, the tablet will guide you to perform wheel alignment or ADAS calibration function by using tire clamp.

NOTE

Rim clamp is selected by default.

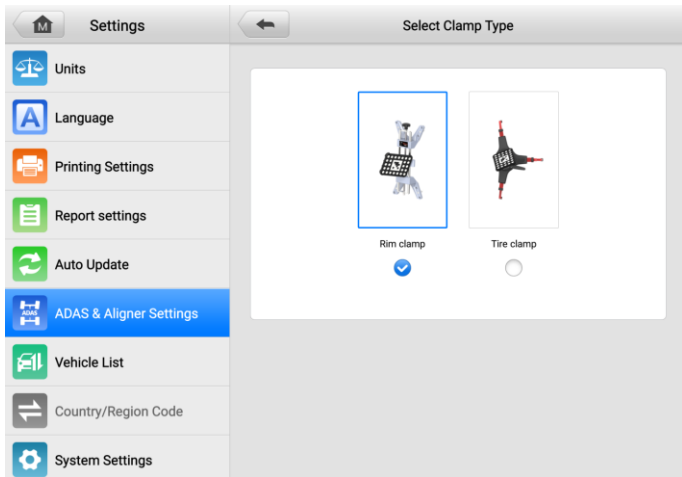

Figure 5-3 Select Clamp Type

5.1.3 Connect Tread Measuring Tool

This setting enables you to connect TBE device for measuring tread. The specific operation of how to connect TBE device is introduced in the previous section, it will not be repeated here. For details, please see tread depth inspection section of [Tread Depth & Pressure Inspection](#).

5.1.4 Select Height Measuring Tool

This section enables you to select ride height measuring tool. There are two options: Tape measure and Ride height target.

- 1) When you select **Tape measure**, you need to measure the ride height as shown in the screen guides, and input the values into corresponding box after measuring. For more details, please see [Ride Height Measurement](#).
- 2) When you select **Ride height target**, the crossbar height will be adjusted automatically and search target in Ride Height Measurement screen, then the ride height will be calculated and displayed on the corresponding input box automatically. For more details, please see [Ride Height Measurement](#).

NOTE

Tape measure is selected by default.

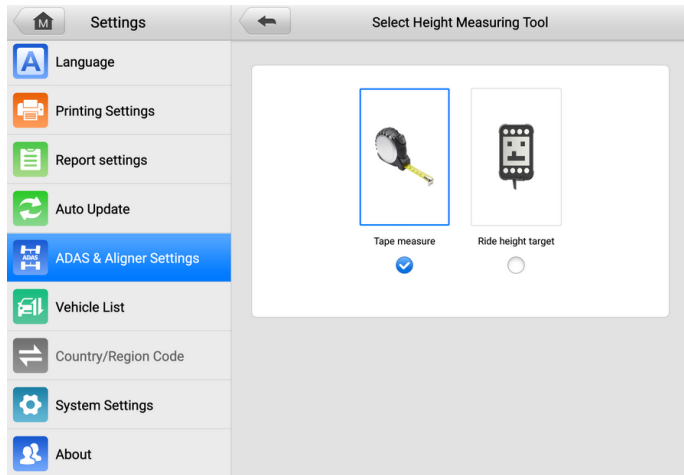

Figure 5-4 Select Height Measuring Tool

5.1.5 Benz Chassis Level Measuring Tool

At present, users need to purchase measuring tool to measure the Mercedes-Benz vehicles' chassis level.

5.1.6 Beep Setting

This setting allows you to enable beep or not when performing rolling compensation, or lifting compensation, or Caster/SAI measurement.

- 1) Toggle the **ON/OFF** button to ON, the beep is enabled. There will be a beep sound during rolling compensation, or lifting compensation, or Caster/SAI measurement procedures.
- 2) Toggle the **ON/OFF** button to OFF, the beep is disabled. There will be no beep sound during rolling compensation, or lifting compensation, or Caster/SAI measurement procedures.

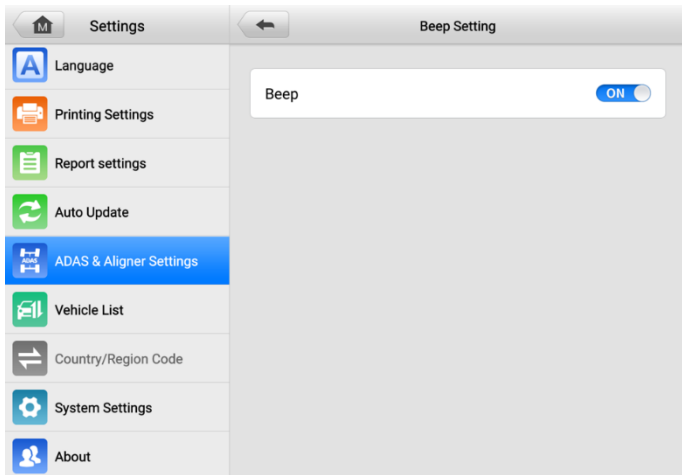

Figure 5-5 *Beep Setting Screen*

5.2 Calibration Frame Connection

The calibration frame connection method is introduced in the previous section; it will not be repeated here. For details, please see [Calibration Frame Connection](#).

5.3 Network Configuration

The network configuration is introduced in the previous section; it will not be repeated here. For details, please see [Network Configuration](#).

5.4 Update

After the calibration frame is connected and the network is configured, tap **Update** from **ADAS & Aligner Settings** to update the calibration frame.

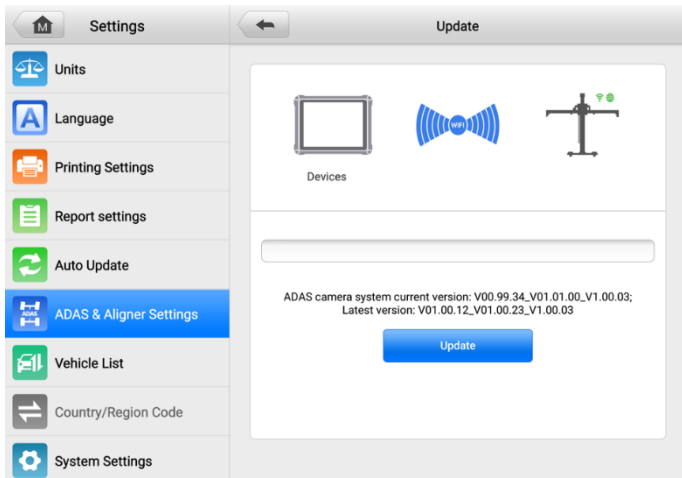

Figure 5-6 Update Screen

5.5 Maintenance & Service

This section covers Inclination Sensor Calibration, Aligner Calibration, Wheel Clamp Target Calibration, Accuracy Check, Calibration Record Report, Accuracy Check Interval, and Target Cleaning Interval.

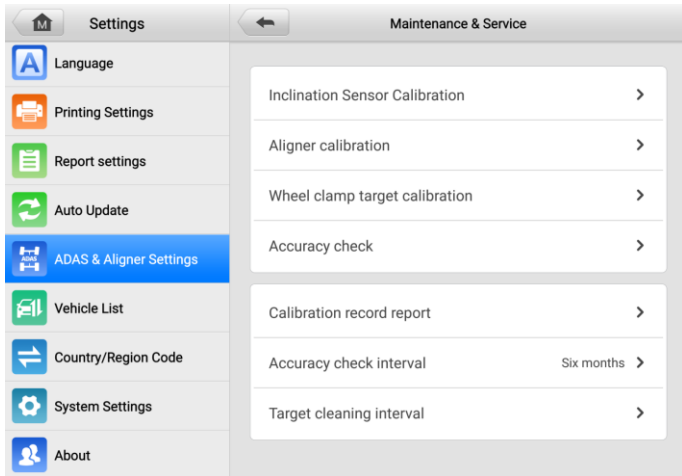

Figure 5-7 Maintenance & Service Screen

5.5.1 Inclination Sensor Calibration

The inclination sensor needs to be calibrated when:

1. Use the IA900WA for the first time.
2. The camera has been disassembled.

➤ **To calibrate inclination sensor**

1. Select **Settings** on the main screen of the tablet.
2. Tap on **ADAS & Aligner Settings** on the left of the screen.
3. Tap on **Maintenance & Service**, then select **Inclination Sensor Calibration**.

NOTE

Ensure the calibration frame Wi-Fi is connected, or the maintenance & service function cannot be activated.

4. As shown in the screen guide, place the calibration frame on a level ground and depress the pedal to fix the main frame. Rotate the buttons A and B to center the pitch and roll level bubbles.

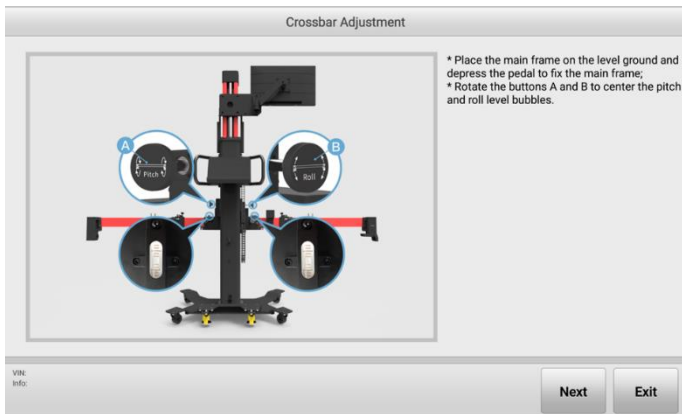

Figure 5-8 Crossbar Adjustment 1

5. Tap **Next**. The inclination sensor will collect data and automatically enter the next screen after the collection is completed. Rotate the button B clockwise to roll the crossbar to the left limit.

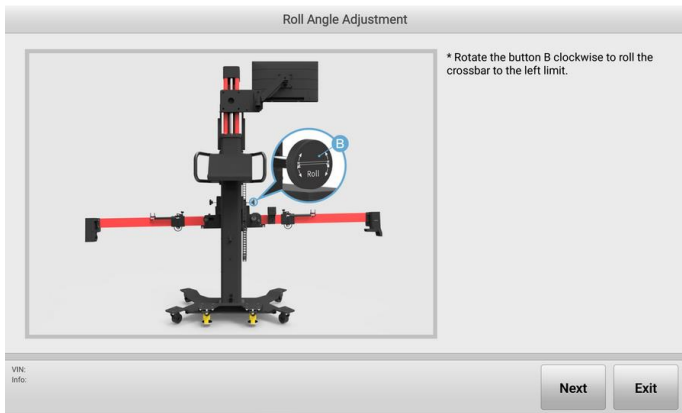

Figure 5-9 Roll Angle Adjustment 1

6. Tap **Next**. The inclination sensor will collect data and automatically enter the next screen after the collection is completed. Follow the screen guides, rotate the button B counterclockwise to roll the crossbar to the right.

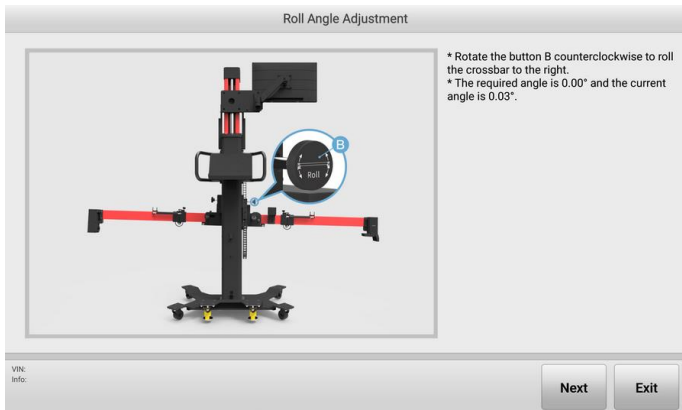

Figure 5-10 Roll Angle Adjustment 2

7. When the current angle is adjusted to the required angle, tap **Next**, the inclination sensor will collect data, and will automatically enter the following screen after the collection is completed. And follow the screen guide, rotate the button B to center the roll level bubble.

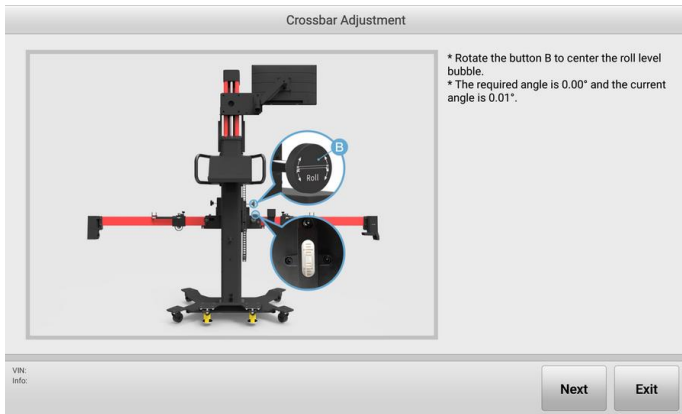



Figure 5-11 Crossbar Adjustment 2

8. After the operation is completed by following the prompts on the screen, the calibration results will appear. If the screen displays , it indicates that the calibration is successful; if the screen displays , it indicates the calibration has failed and needs to be recalibrated.

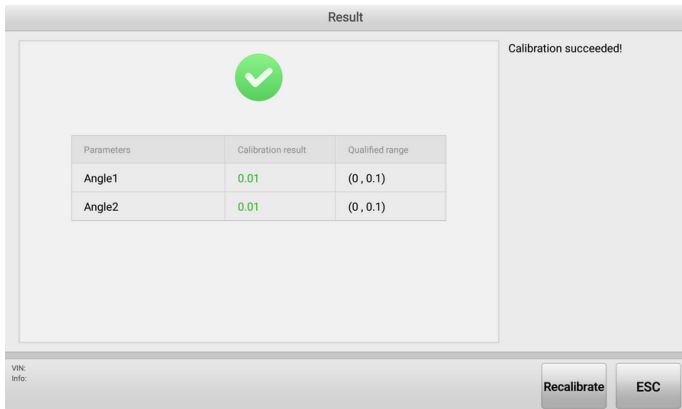

Figure 5-12 Calibration Result Screen

5.5.2 Aligner Calibration

The aligner needs to be calibrated when:

1. The camera has been disassembled.
2. Accuracy check has failed.

NOTE

To perform Aligner calibration, a professional calibration tool (AUTEL-CSC0500/10) is required. You can contact your local dealer or manufacturer for calibration.

➤ **To calibrate aligner**

1. Select **Settings** on the main screen of the tablet.
2. Tap on **ADAS & Aligner Settings** on the left of the screen.
3. Tap on **Maintenance & Service**, then select **Aligner calibration**.

NOTE

Ensure the calibration frame Wi-Fi is connected, or the maintenance & service function cannot be activated.

4. Place the calibration bar about 2.2 m in front of the calibration frame. Install the front wheel targets on the calibration bar, align the location pin with the locating hole, and tighten the nut.

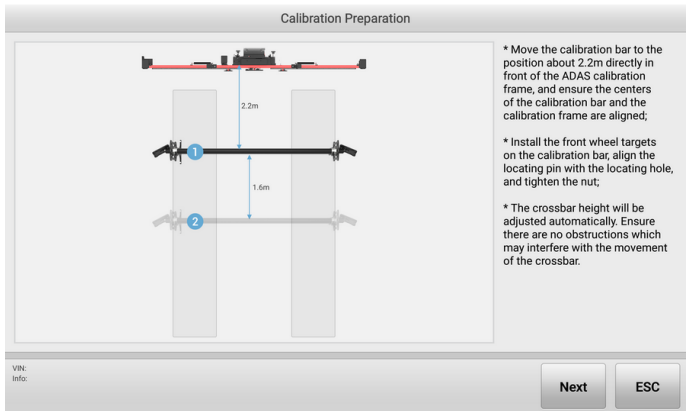

Figure 5-13 Aligner Calibration Preparation

5. Tap **Next**, the crossbar height will be adjusted automatically and search the target, and will enter the following screen. Follow the screen guide, move the calibration bar so that the values of 'Offset', 'L-Distance', and 'Distance Diff' are displayed in green.



Figure 5-14 Aligner Calibration 1



Figure 5-15 Aligner Calibration 2

- Then tap **Next** to enter the following screen. Rotate the calibration bar according to the screen prompts to collect data. When the arrows and the indicated block images turn green, then stop rotating the crossbar.

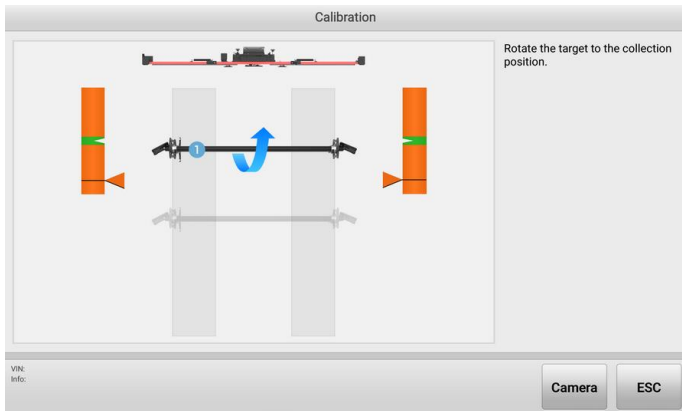

Figure 5-16 Calibration Screen 1

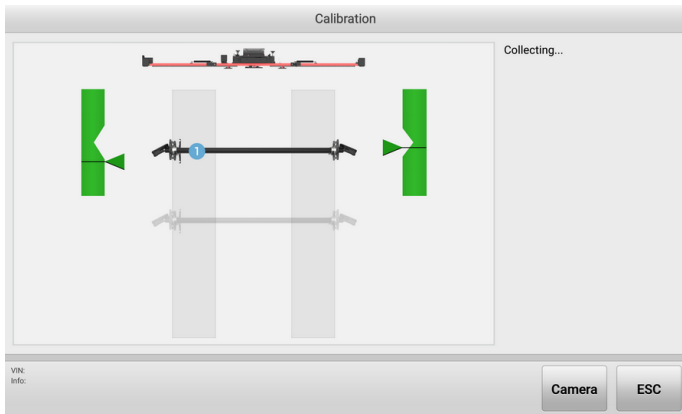



Figure 5-17 Calibration Screen 2

7. After collecting data, the calibration result screen will display, as shown in the figure below. If the screen displays , it indicates that the calibration is successful; if the screen displays , it indicates the calibration has failed, and needs to be recalibrated.

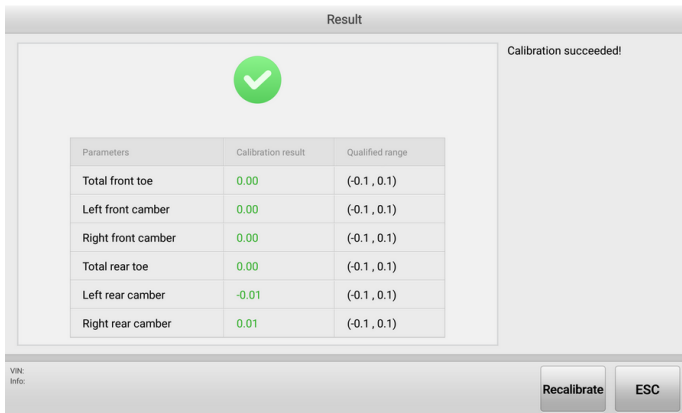

Figure 5-18 Calibration Result

- Then remove the front wheel targets from the calibration bar and install the rear wheel targets on the calibration bar. And place the calibration bar about 5.4 m in front of the calibration frame. Complete the calibration steps as shown in the screen guides. Since the calibration steps are roughly the same and clearly illustrated on the tablet, it will not be repeated here.

5.5.3 Wheel Clamp Target Calibration

When the matching wheel clamp (rim clamp/tire clamp), or the target has been replaced, the newly assembled wheel clamp (rim clamp/tire clamp) or target needs to be recalibrated.

NOTE

As mentioned before, the illustrations involving clamps in this manual are based on the use of rim clamps. Here we select rim clamp and target for calibration illustration, the procedures for tire clamp and target calibration are roughly the same, so it will not be repeated here.

5.5.3.1 Use Calibration Bar

- **To calibrate wheel clamp (rim clamp) and target by using calibration bar**
 - Prepare a professional calibration tool — calibration bar AUTEL-CSC0500/10 by yourself.
 - Select **Settings** on the main screen of the tablet.
 - Tap on **ADAS & Aligner Settings** on the left of the screen.
 - Tap on **Maintenance & Service**, then select **Wheel clamp target calibration**.

5. Select **Wheel clamp target calibration — with calibration bar**, the tablet will remind you of the notes for wheel clamp (rim clamp) and target calibration.

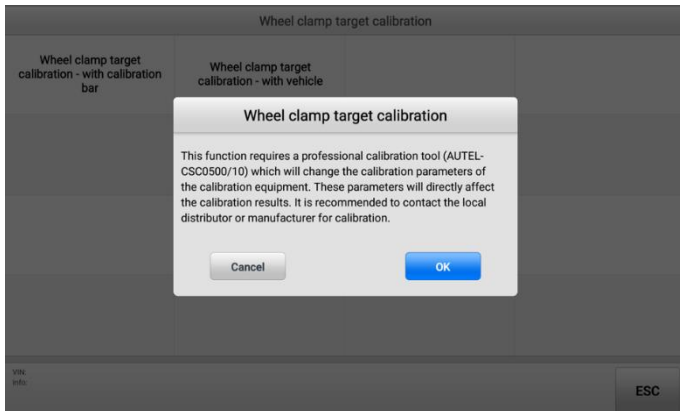

Figure 5-19 Select Calibration Method

6. After carefully reading the notes, tap **OK** to select target for calibration. Here we select **Left front wheel target** (which is well installed on the left front rim clamp) for illustration.

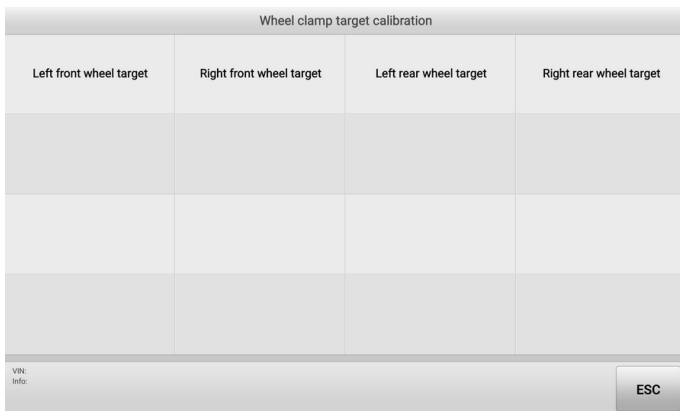

Figure 5-20 Select Target for Calibration

7. The tablet will automatically display the calibration preparations after you select the target that needs for calibration. Follow the screen guides, move the calibration bar to the position about 2.2 m directly in front of the IA900WA calibration frame, and ensure the centers of the calibration bar and the calibration frame are aligned. Then install the left front wheel clamp (rim clamp)

and left front target on the calibration bar, align the locating pin with the locating hole, and tighten the nut.

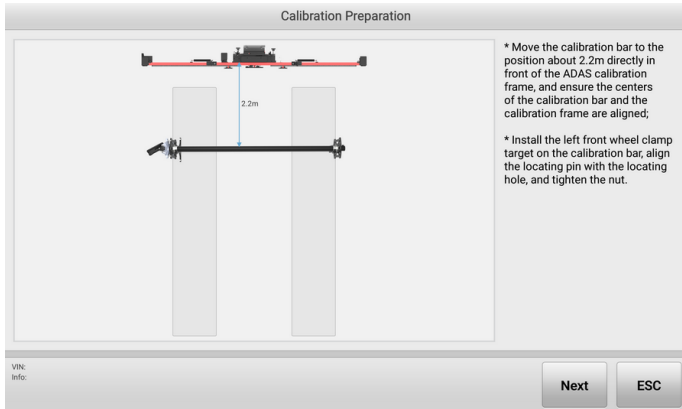

Figure 5-21 Calibration Preparation (Use Calibration Bar)

8. After the above preparations are completed, tap **Next** to continue. The tablet will display the current distance between the wheel clamp (rim clamp) & target and the camera kit and prompt you that the distance should be 2.0 to 2.4 m. If the distance is not within that range, move the calibration bar to adjust the distance to the required range.

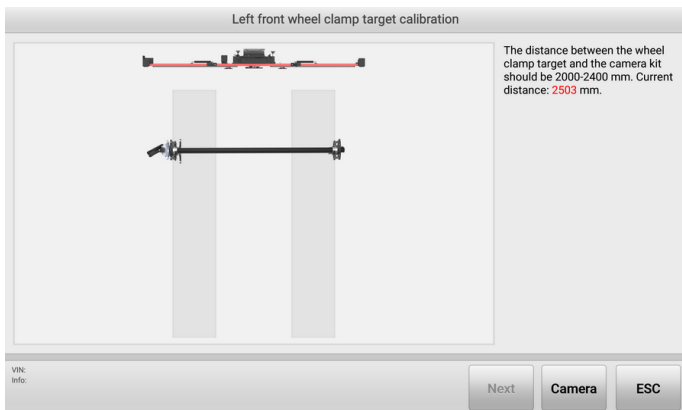

Figure 5-22 Start Calibration (Use Calibration Bar) 1

9. Tap **Next** when the distance is adjusted to the required range, the tablet will prompt you that everything is ready for the later operations.

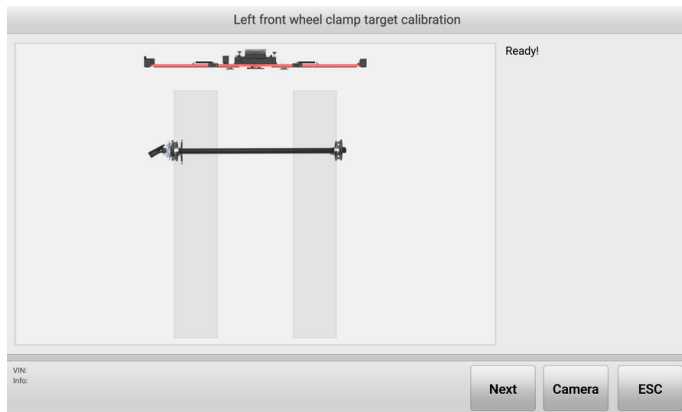

Figure 5-23 Start Calibration (Use Calibration Bar) 2

10. Tap **Next** to continue. Follow the screen guide, rotate the calibration bar so that the targets are in the collection position.

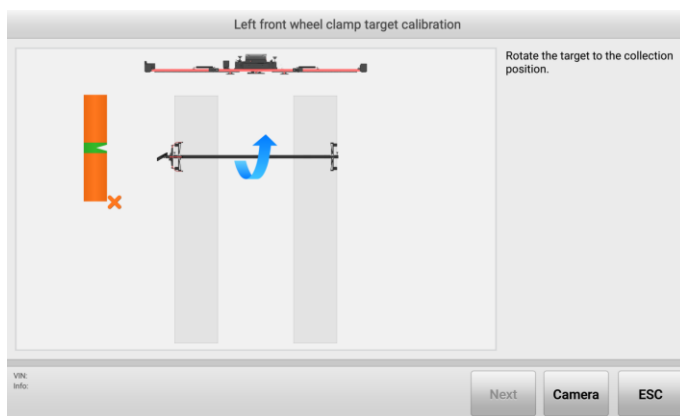

Figure 5-24 Start Calibration (Use Calibration Bar) 3

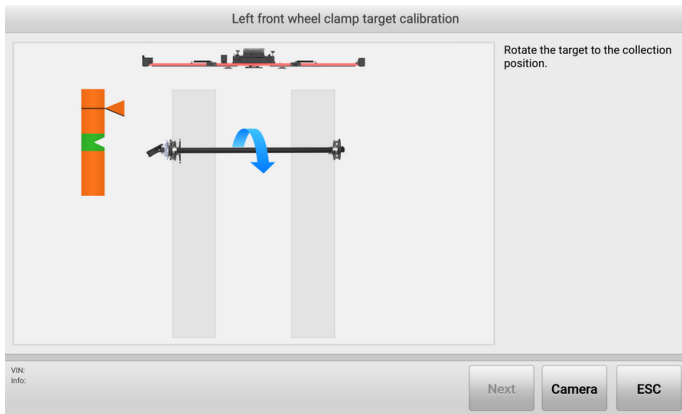

Figure 5-25 Start Calibration (Use Calibration Bar) 4

11. When the arrows and the indicated block images turn green, stop rotating the crossbar. The tablet will start data collecting automatically.

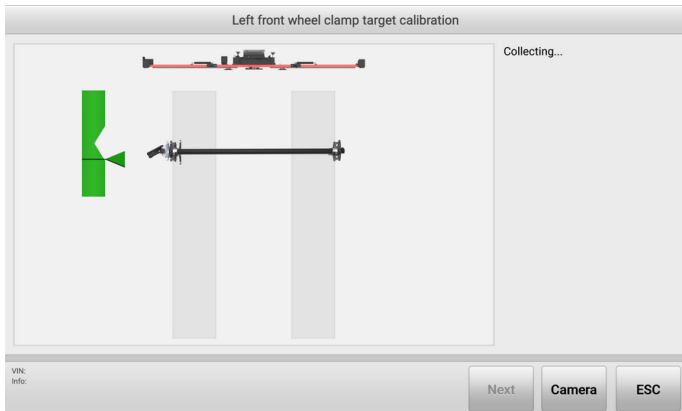



Figure 5-26 Start Calibration (Use Calibration Bar) 5

12. After data collecting, the tablet will display the calibration result automatically. If the screen displays , it indicates that the calibration is successful, you can tap **ESC** to exit the function; if the screen displays , it indicates the calibration has failed, you can tap **Recalibrate** to calibrate again.

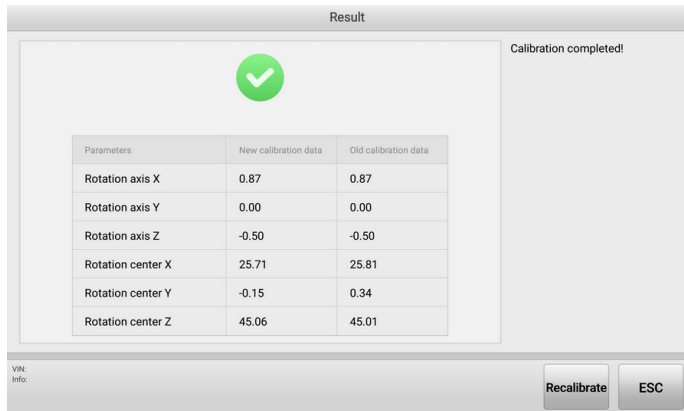

Figure 5-27 Calibration Result Screen

5.5.3.2 Use Vehicle

- **To calibrate wheel clamp (rim clamp) and target by using vehicle**
 1. Select **Settings** on the main screen of the tablet.
 2. Tap on **ADAS & Aligner Settings** on the left of the screen.
 3. Tap on **Maintenance & Service**, then select **Wheel clamp target calibration**.
 4. Select **Wheel clamp target calibration — with vehicle** from the right of the screen. See [Figure 5-19 Select Calibration Method](#).
 5. The following screen displays, then select the target that needs to be calibrated. For example, select **Left front wheel target** (which is well installed on the left front rim clamp). See [Figure 5-20 Select Target for Calibration](#).
 6. As shown in the screen guides, drive the vehicle onto the lift, steer ahead, lock steering wheel holder stand tool, place transmission in neutral, release parking brake. Then install the left front wheel clamp (rim clamp) and left front target on left front wheel and raise the front axle.

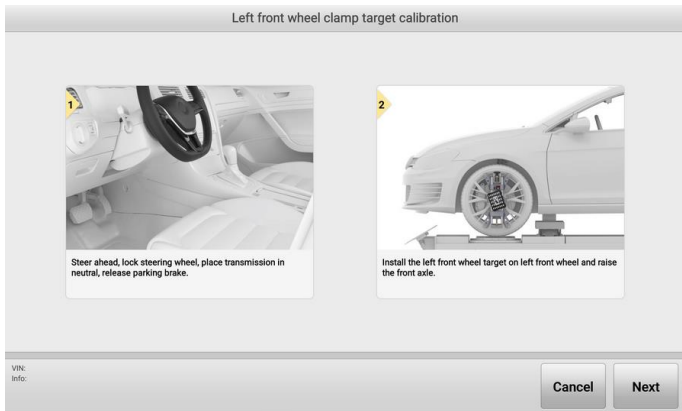

Figure 5-28 Calibration Preparation (Use Vehicle) 1

7. Tap **Next** to continue. Follow the screen guides, place the calibration frame about 2.2 m from the center of the front wheel, and ensure that the centers of the calibration frame and the vehicle are aligned. Then press **UP** and **DOWN** buttons on the back of the calibration frame to adjust the crossbar height so that the crossbar is roughly at the same height as the center of the front wheel.

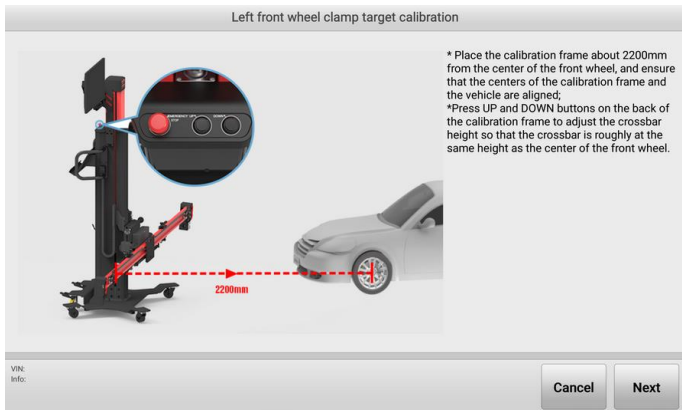

Figure 5-29 Calibration Preparation (Use Vehicle) 2

8. If the above operations are completed, tap **Next** to continue. The tablet will display the current distance between the wheel clamp (rim clamp) & target and the camera kit and prompt you that the distance should be 2.0 to 2.4 m. If the distance is not within that range, move the calibration frame to adjust the distance to the required range.

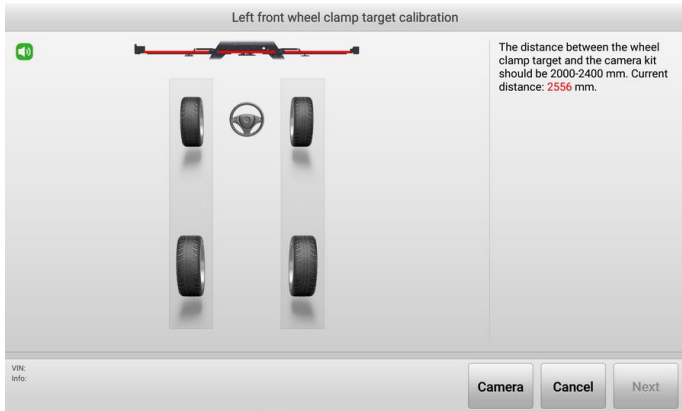

Figure 5-30 Start Calibration (Use Vehicle) 1

9. Tap **Next** when the distance is adjusted to the required range, the tablet will prompt you that everything is ready for the later operations.

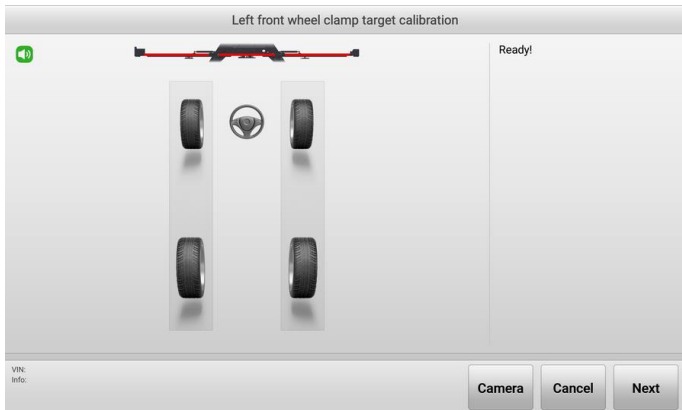

Figure 5-31 Start Calibration (Use Vehicle) 2

10. Turn the wheel as shown in the screen guides.

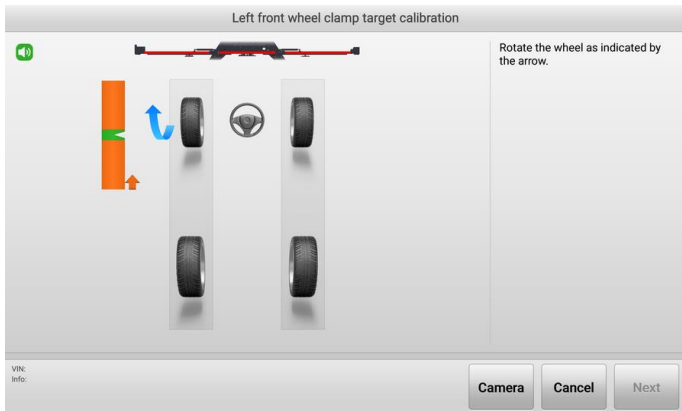

Figure 5-32 Start Calibration (Use Vehicle) 3

11. When the arrows and the indicated block images turn green, stop turning the wheel. The tablet will start data collecting automatically.

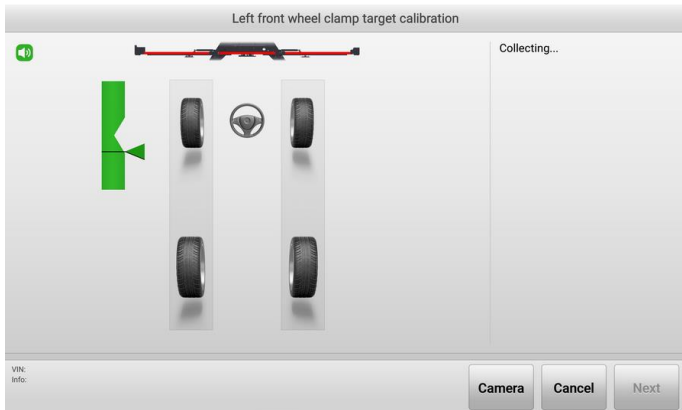



Figure 5-33 Start Calibration (Use Vehicle) 4

12. After data collecting, the tablet will display the calibration result automatically. If the screen displays , it indicates that the calibration is successful, you can tap **ESC** to exit the function; if the screen displays , it indicates the calibration has failed, you can tap **Recalibrate** to calibrate again.

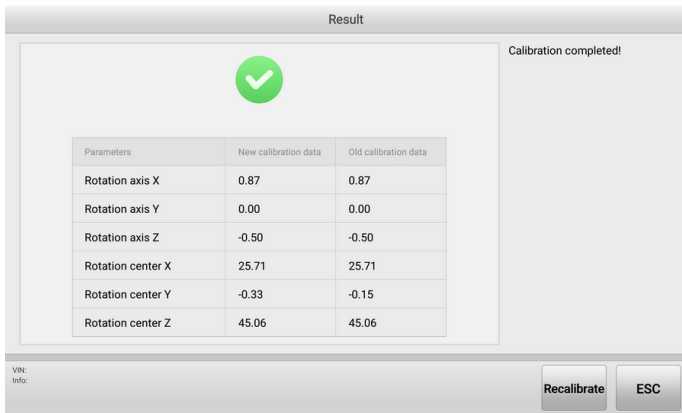

Figure 5-34 Calibration Result Screen (Use Vehicle)

5.5.4 Accuracy Check

Aligner accuracy check is recommended when:

1. The aligner suffered a high-intensity collision.
2. The accuracy check has not been performed for more than six months.

The software provides three kinds of accuracy check methods: Accuracy Check (Use Calibration Bar); Accuracy Check (Use Vehicle); Quick Accuracy Check.

5.5.4.1 Use Calibration Bar

Performing accuracy check with calibration bar, the overall accuracy of the measurement system composed of cameras and wheel clamp and target can be accurately and reliably detected.

➤ To perform accuracy check with calibration bar

1. Select **Settings** on the main screen of the tablet.
2. Tap on **ADAS & Aligner Settings** on the left of the screen.
3. Tap on **Maintenance & Service**, then select **Accuracy Check**.

NOTE

Ensure the calibration frame Wi-Fi is connected, or the maintenance & service function cannot be activated.

4. Select **Accuracy Check – with calibration bar** in the right of the screen.
5. According to the screen guides, move the calibration bar to the position about 2.2 m directly in front of the calibration frame. Install the front wheel clamps (rim

clamps) and targets on the calibration bar, align the locating pin with the locating hole, and tighten the nut.

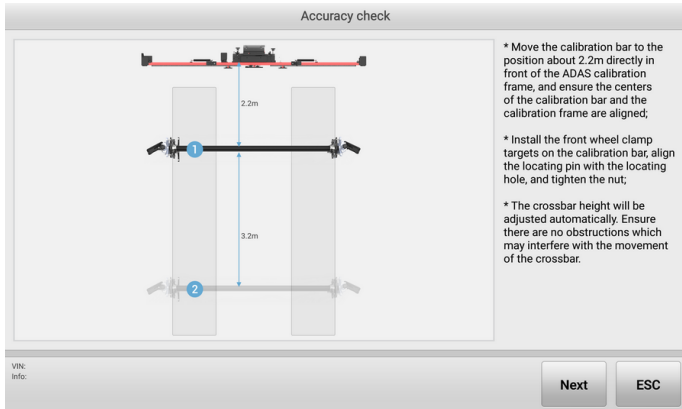

Figure 5-35 Accuracy Check Screen (Use Calibration Bar) 1

6. Tap **Next**, the crossbar height will be adjusted automatically, and will enter the following screen. As shown in the screen guide, move the calibration bar so that the values of 'Offset', 'L-Distance', and 'Distance Diff' are displayed in green.

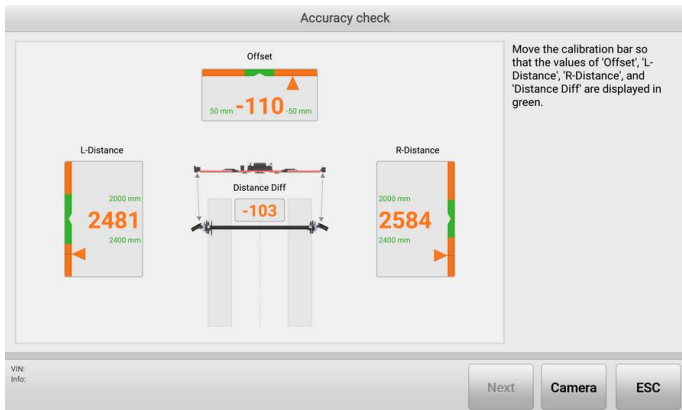

Figure 5-36 Accuracy Check Screen (Use Calibration Bar) 2

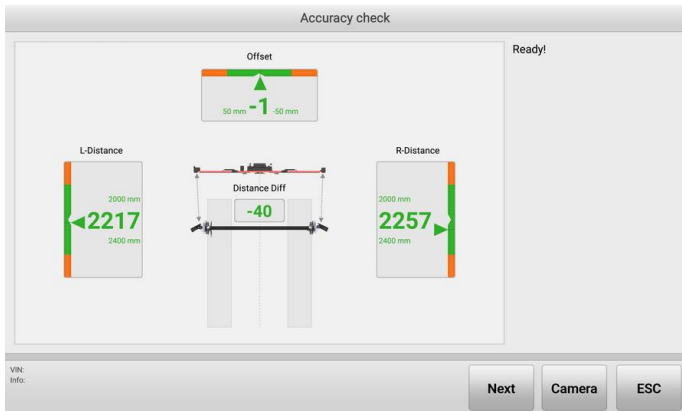

Figure 5-37 Accuracy Check Screen (Use Calibration Bar) 3

7. Then tap **Next** to enter the following screen. Rotate the calibration bar according to the screen prompts to collect data. When the arrows and the indicated block images turn green, then stop rotating the calibration bar.

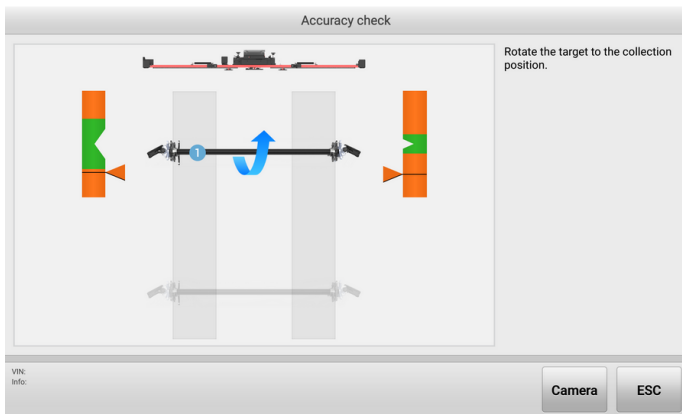

Figure 5-38 Accuracy Check Screen (Use Calibration Bar) 4

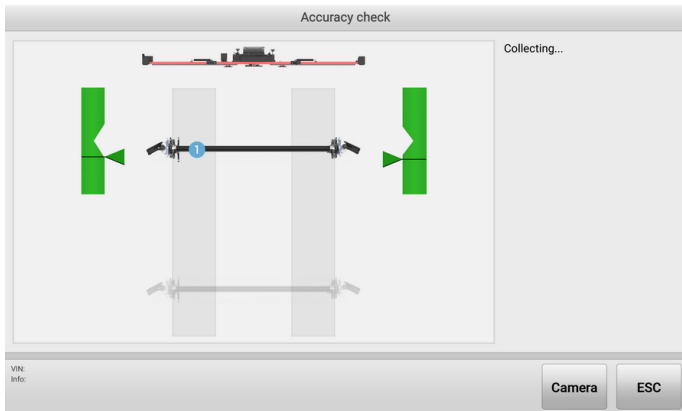



Figure 5-39 Accuracy Check Screen (Use Calibration Bar) 5

8. The system will automatically enter the next screen. After the data is successfully collected, the calibration result will display automatically. If the screen displays , it indicates that the calibration is successful; if the screen displays , it indicates the calibration has failed, and needs to be recalibrated.

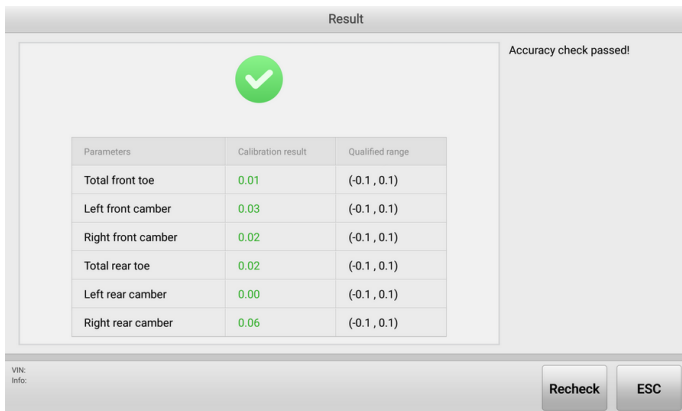

Figure 5-40 Accuracy Check Result Screen

5.5.4.2 Use Vehicle

Performing accuracy check with vehicle, the overall accuracy of the measurement system consisting of cameras and rim clamp and target can be detected by vehicles without a calibration bar. However, the accuracy of the inspection is affected by the condition of the vehicle, so it is recommended to select a sports vehicle having a good condition for inspection.

➤ **To perform accuracy check with vehicle**

1. Select **Settings** on the main screen of the tablet.
2. Tap on **ADAS & Aligner Settings** on the left of the screen.
3. Tap on **Maintenance & Service**, then select **Accuracy Check**.

 **NOTE**

Ensure the calibration frame Wi-Fi is connected, or the maintenance & service function cannot be activated.

4. Select **Accuracy Check — with vehicle** in the right of the screen.
5. Follow the screen guide to set the vehicle into required status.

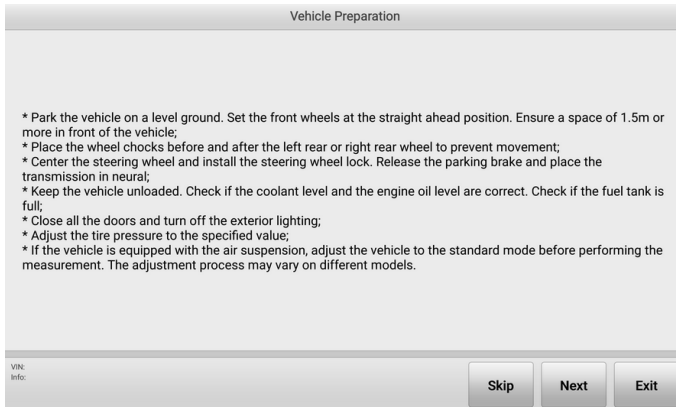

Figure 5-41 Vehicle Preparation

6. Tap **Next** if the vehicle is set to the required status. Then follow the guides shown on the screen to position the auxiliary tool step by step.

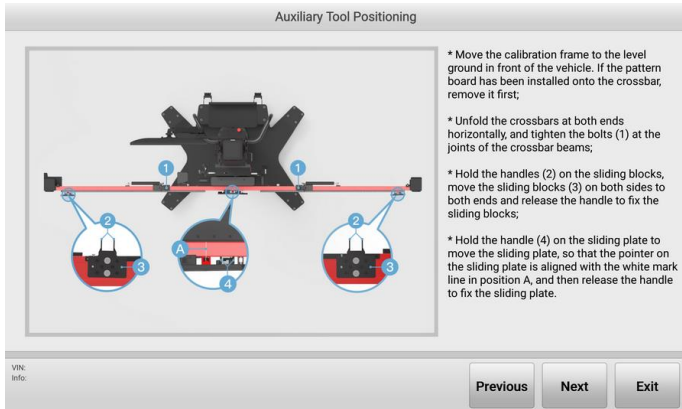

Figure 5-42 Auxiliary Tool Positioning 1

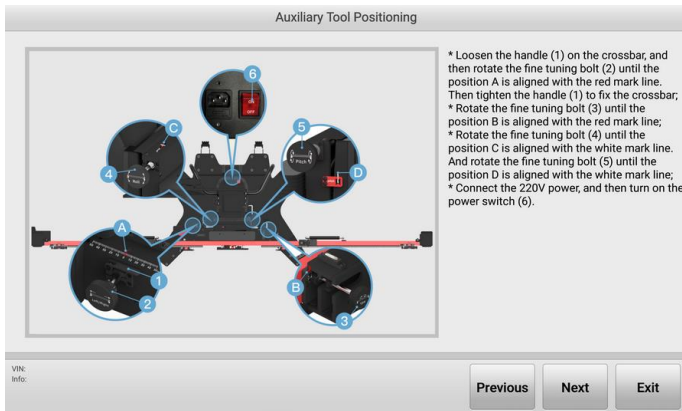

Figure 5-43 Auxiliary Tool Positioning 2

7. Place the calibration frame directly in the front of the vehicle, and follow the screen guides to operate the calibration frame and auxiliary tools.

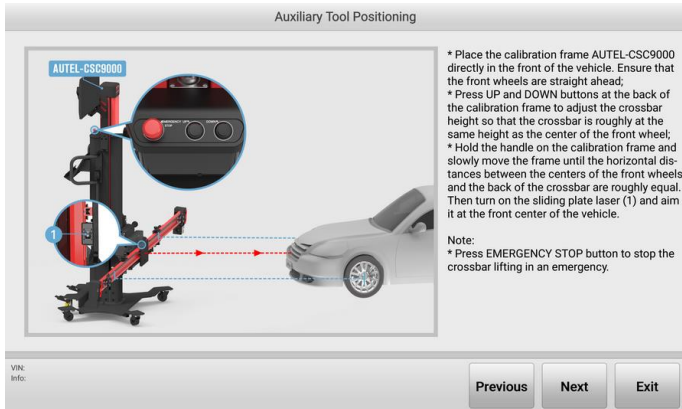

Figure 5-44 Auxiliary Tool Positioning 3

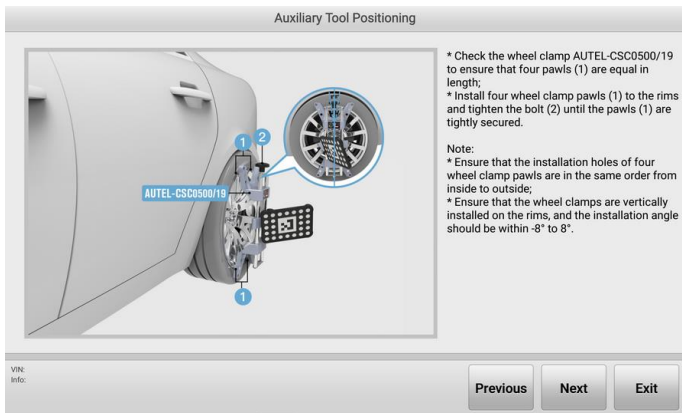

Figure 5-45 Auxiliary Tool Positioning 4

9. After the auxiliary tools are well positioned, tap the **Next** button, the crossbar will be adjusted automatically and search the target, and the tablet will enter the following screen. Follow the screen guide to move the rear wheel chock backward for about 30 cm, and push the vehicle backward, so that the values are displayed green. When the arrows and indicated block images are displayed green, stop pushing the vehicle and wait the tablet to enter the next screen.

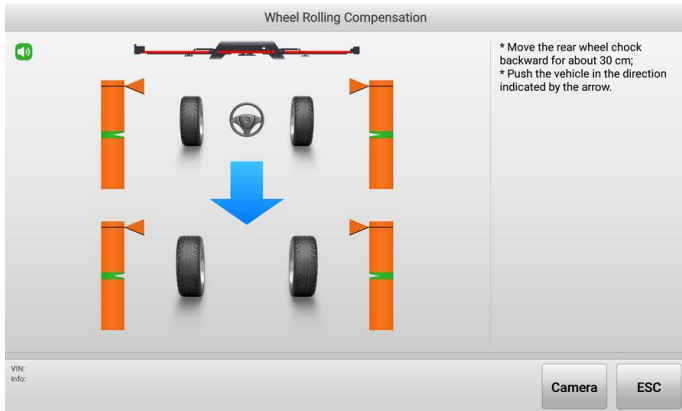

Figure 5-46 Wheel Rolling Compensation 1

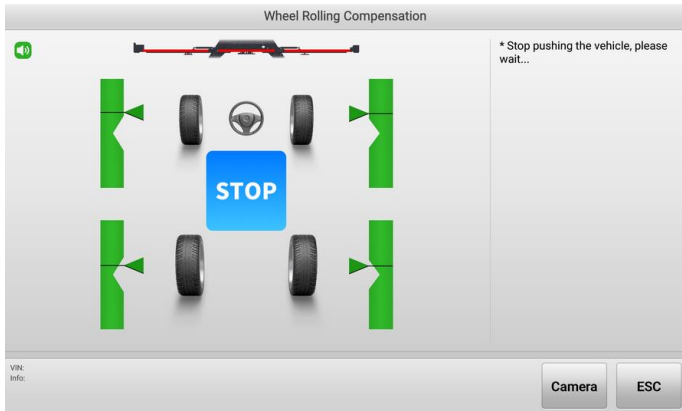

Figure 5-47 Wheel Rolling Compensation 2

10. Then push the vehicle forward. When the arrows and indicated block images are displayed green, stop pushing the vehicle and wait the tablet to enter the next screen.

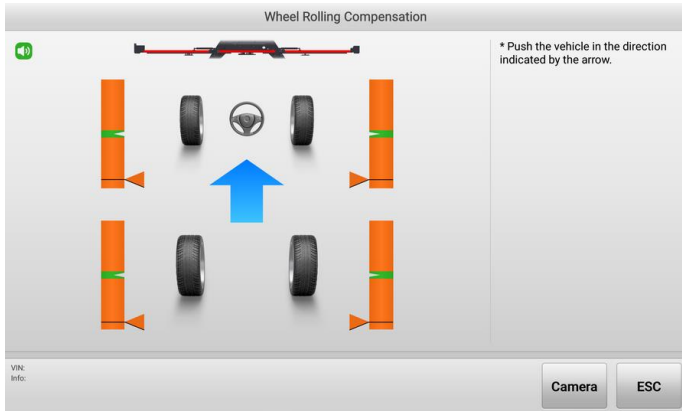

Figure 5-48 Wheel Rolling Compensation 3

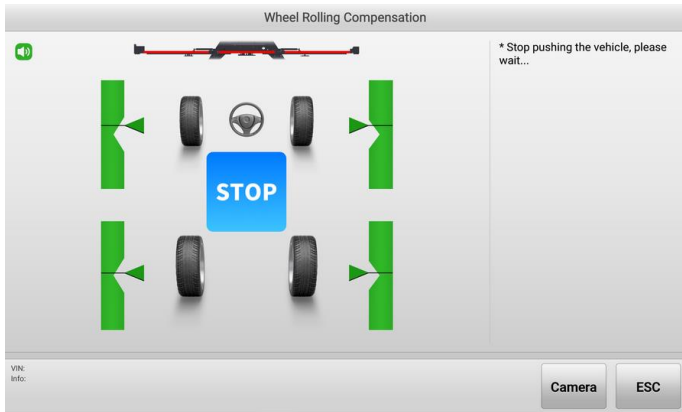



Figure 5-49 Wheel Rolling Compensation 4

11. Place the calibration frame directly behind the rear of the vehicle, then follow the screen guides to complete the procedures, which are similar to the previous operation.
12. After the operation is completed, the calibration result will display automatically. If the screen displays , it indicates that the calibration is successful; if the screen displays , it indicates the calibration has failed, and needs to be recalibrated.

5.5.4.3 Quick Accuracy Check

Quick accuracy check is automatically performed every six months by default. The Accuracy Check Interval can be changed through Wheel Alignment Software Settings. Quick accuracy check can detect problems in the measurement system formed by the camera and target, but not including the wheel clamp or tire clamp.

➤ **To perform quick accuracy check**

1. Select **Settings** on the main screen of the tablet.
2. Tap on **ADAS & Aligner Settings** on the left of the screen.
3. Tap on **Maintenance & Service**, then select **Accuracy Check**.

 **NOTE**

Ensure the calibration frame Wi-Fi is connected, or the maintenance & service function cannot be activated.

4. Select **Quick accuracy check** in the right of the screen.
5. Follow the screen guide to set the vehicle into required status.

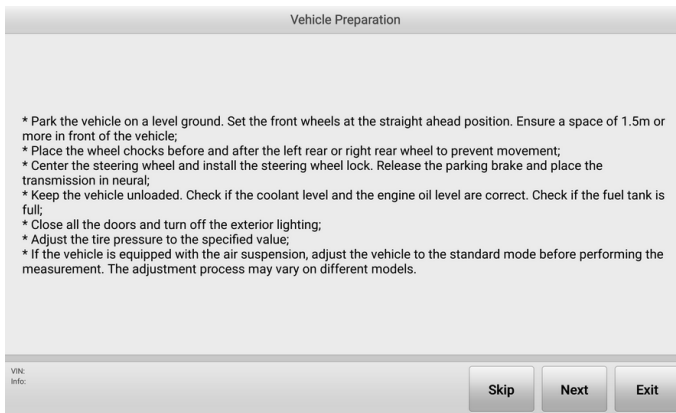

Figure 5-50 Vehicle Preparation Guide

6. Tap **Next** if the vehicle is set to the required status well. Then follow the screen guide to position the auxiliary tool step by step.

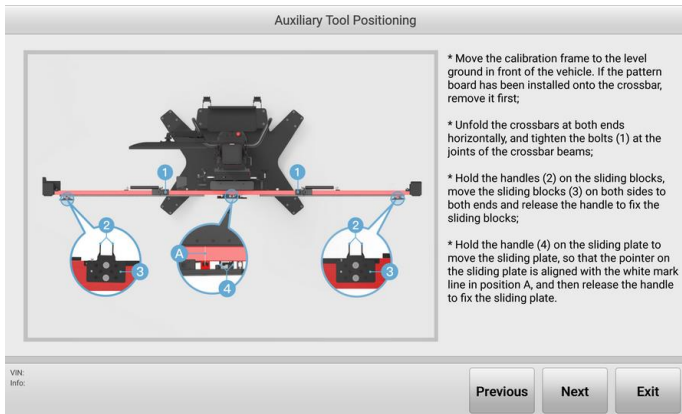

Figure 5-51 Auxiliary Tool Positioning 1

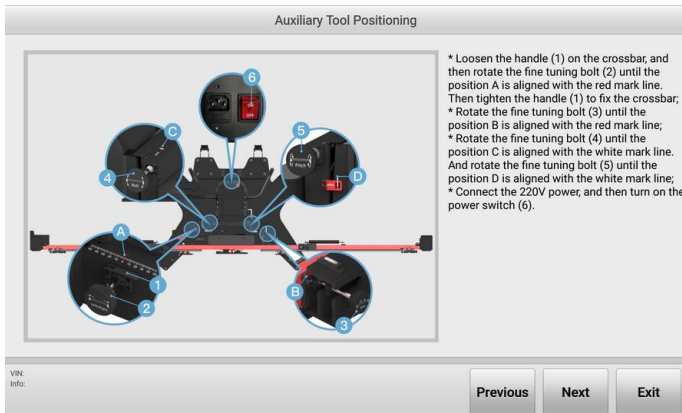

Figure 5-52 Auxiliary Tool Positioning 2

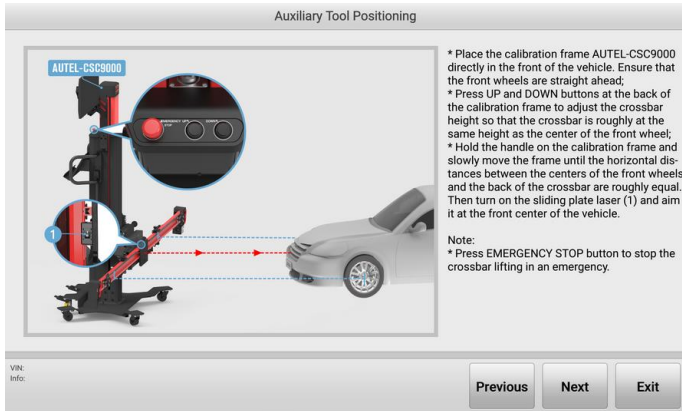

Figure 5-53 Auxiliary Tool Positioning 3

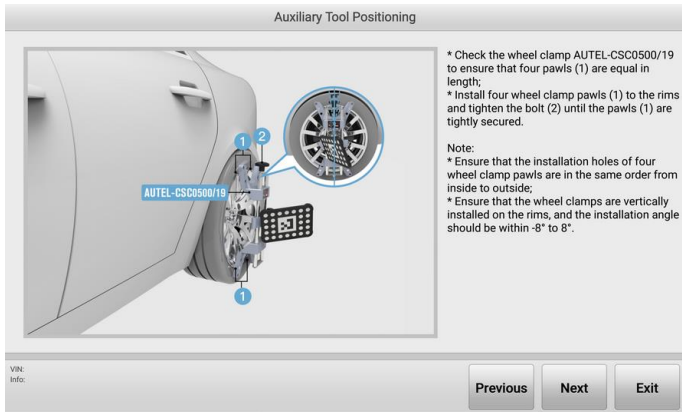

Figure 5-54 Auxiliary Tool Positioning 4

7. After positioning the auxiliary tool. Tap the **Next** button, the crossbar height will be adjusted automatically and search the target, and will enter the following screen.

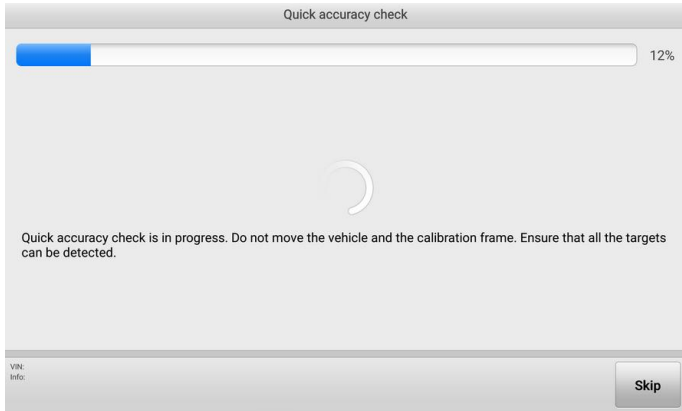



Figure 5-55 Quick Accuracy Check

8. The quick accuracy check result will display on the screen after the check progress is completed. If the screen displays , it indicates that the calibration is successful; if the screen displays , it indicates the calibration has failed, and needs to be recalibrated.

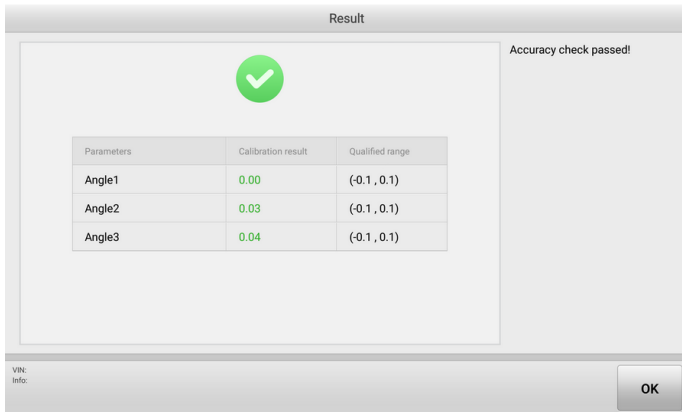

Figure 5-56 Quick Accuracy Check Result

5.5.5 Calibration Record Report

All the calibration records are saved here, you can see when and what type of calibration the device was performed.

5.5.6 Accuracy Check Interval

This function enables you to set the accuracy check intervals, four options are available: three months, six months, one year, never. The default accuracy check interval is six months.

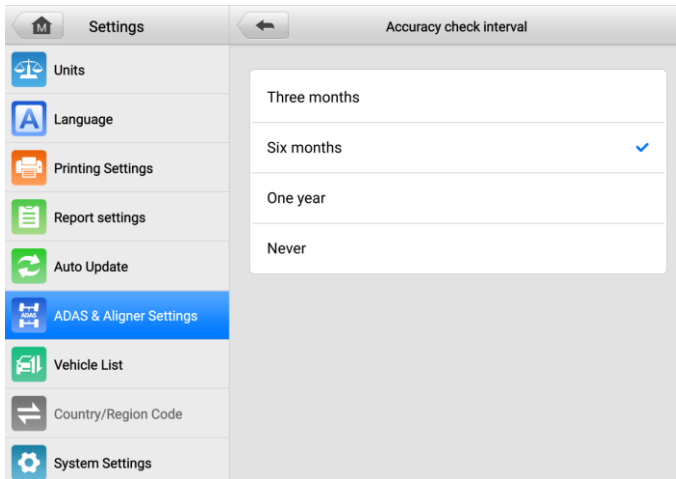

Figure 5-57 Accuracy Check Interval Setting Screen

5.5.7 Target Cleaning Interval

This function helps in reminding the operator about the target cleaning frequency, which can be selected in terms of alignment numbers or intervals.

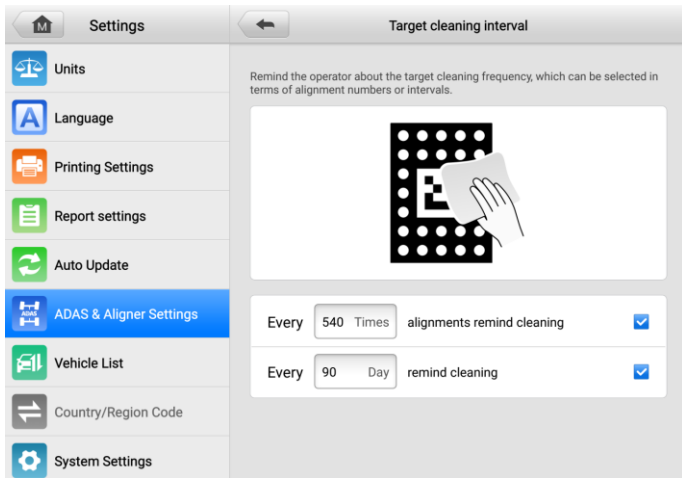

Figure 5-58 Target Cleaning Interval Setting Screen

5.6 Wheel Alignment Software Settings

Vehicle Inspection, Measurement Preparation, Measurement Results, Customized Specifications Management, and Restore Default Settings are included in this section.

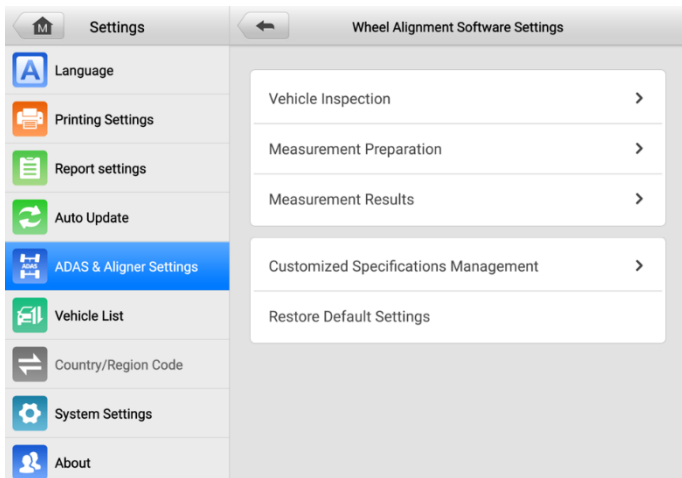

Figure 5-59 Wheel Alignment Software Settings

5.6.1 Vehicle Inspection

This function enables you to:

1. Set whether to enable tire inspection or not. This setting will affect whether the tablet will guide you to perform Tread Depth & Pressure Inspection in the Vehicle Check procedure. If the Vehicle Inspection is enabled, the tablet will guide you to perform Tread Depth & Pressure Inspection; if disabled, the tablet will not guide you to perform Tread Depth & Pressure Inspection. For how to perform Tread Depth & Pressure Inspection, please refer to [Tread Depth & Pressure Inspection](#).
 - If the tire inspection is activated, you are able to set:
 - 1) Tread depth measuring method: Single Check or All Tread Check.
 - 2) Minimum Tread Depth: when the tread depth is less that the minimum tread depth value you set, the tablet will prompt you to replace the tire immediately.
 - 3) Warning Tread Depth: when the tread depth is less than the value you set, the tablet will issue a warning.
2. Set whether to enable chassis inspection or not. This setting will affect whether the tablet will guide you to perform Chassis Inspection in the Vehicle Check procedure. If the Chassis Inspection is enabled, the tablet will guide you to perform Chassis Inspection; if disabled, the tablet will not guide you to perform Chassis Inspection. For how to perform Chassis Inspection, please refer to [Chassis Inspection](#).

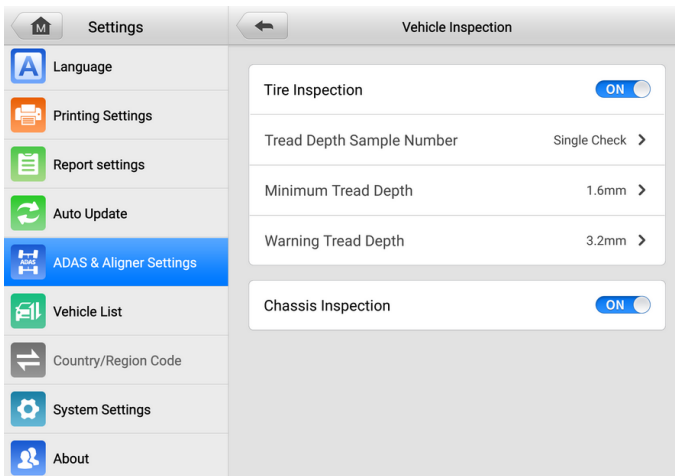

Figure 5-60 Vehicle Inspection Settings Screen

5.6.2 Measurement Preparation

This function enables/disables measurement preparation, and will affect whether the tablet will guide you to measure ride height. If the Measurement Preparation is turned on, the tablet will guide you to measure ride height; if turned off, the tablet will not guide you to measure ride height. For how to measure ride height, please refer to [Ride Height Measurement](#).

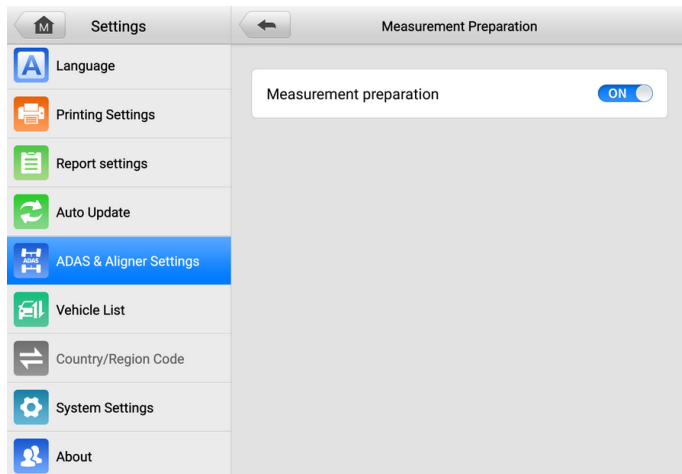

Figure 5-61 Measurement Preparation Setting Screen

5.6.3 Measurement Results

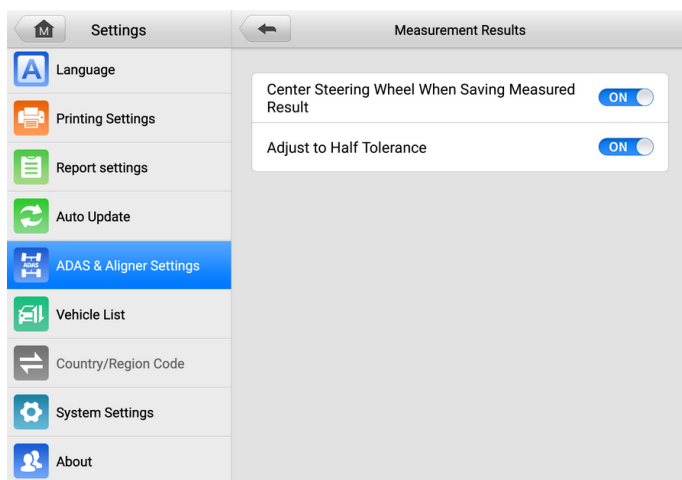

Figure 5-62 Measurement Results Setting Screen

This function enables you to:

1. Whether to center steering wheel when saving measured result.
 - Turn on the function
 - 1) If the wheels are not in straight ahead position, tap **Save Before Repair** in Measured Result screen, the guide for setting the wheels straight ahead will be displayed on the screen.



Figure 5-63 Save Before Repair Screen 1

- 2) When the wheels are in straight ahead position, the tablet will save the data automatically and display the following screen.

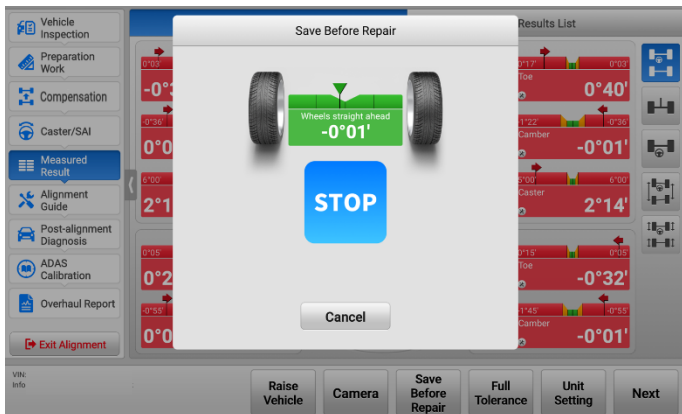

Figure 5-64 Save Before Repair Screen 2

- Turn off the function: the data will be saved directly after tapping **Save Before Repair** in Measured Result screen.

2. Whether to change to Half Tolerance mode.

- 1) If the Half Tolerance mode is enabled, the Measured Result will display in Half Tolerance mode, and the screen looks like the image below.



Figure 5-65 Measured Result (Half Tolerance) Screen

- 2) If the Half Tolerance mode is disabled, the Measured Result will display in Full Tolerance mode, and the screen looks like the image below.



Figure 5-66 Measured Result (Full Tolerance) Screen

5.6.4 Customized Specifications Management

The customized specifications are not available currently.

5.6.5 Restore Default Settings

This function enables you to restore the default settings of wheel alignment software.

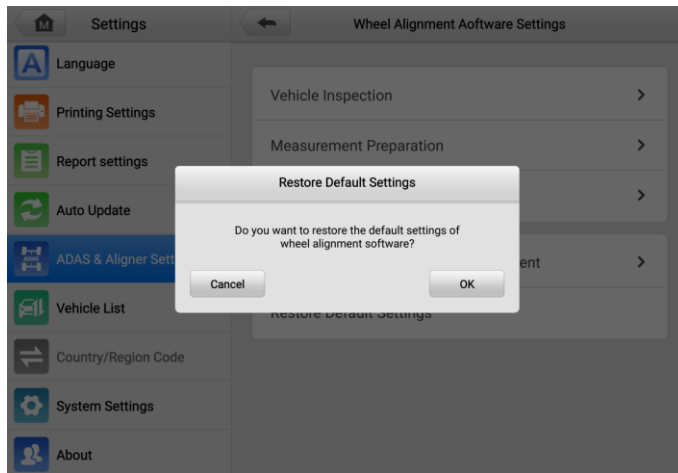

Figure 5-67 Restore Default Settings Screen

The default settings are as follows:

Table 5-1 Default Settings

Item	Default Setting
Angle Display Format	Degree & Minute
Toe Display Format	Degree & Minute
Ride Height Unit	mm
Tread Depth Unit	mm
Track Width & Wheelbase Unit	mm
Tire Pressure Unit	bar

Item	Default Setting
Weight Unit	kg
Clamp Type	Rim Clamp
Connect Tread Measuring Tool	Enable TBE Device Searching
Select Height Measuring Tool	Tape Measure
Benz Chassis Level Measuring Tool	No Tool
Beep Setting	Turn On
Accuracy Check Interval	Six Months
Target Cleaning Interval	Times: 540 Times Days: 90 Days
Vehicle Inspection	Turn On
Tread Depth Sample Number	Single Check
Minimum Tread Depth	1.6 mm
Warning Tread Depth	3.2 mm
Chassis Inspection	Turn On
Measurement Preparation	Turn On
Center Steering Wheel When Saving Measured Result	Turn On
Adjust to Half Tolerance	Turn On

6

ADAS Calibration Function

After connecting with IA900WA, MaxiSys ADAS diagnostic tablet allows you to perform ADAS calibration function by utilizing various sensors installed on the vehicle, including Adaptive Cruise Control (ACC), Blind Spot Detection (BSD), Rear View Camera (RVC), Lane Keep Assist (LKA), Around View Monitoring (AVM), Night Vision System (NVS), and so on.

This chapter describes the calibration procedures (take Audi A7 2011 vehicle as an example) of six different ADAS calibration functions, namely ACC calibration, camera system rear view calibration, HUD calibration, camera system rear view calibration, night vision camera calibration, and on-board camera calibration. On which situation that needs calibration, the required calibration tools, the calibration preparations, notes, and procedures are introduced in detail. As the calibration procedures may vary by vehicles, please follow the step-by-step instructions on the compatible diagnostic tablet to complete the calibration.

6.1 Preparatory Work

Before performing ADAS calibration function, you need to connect the IA900WA to MaxiSys Ultra tablet first, then configure the tablet's network and connect the tablet with vehicle by VCI device. You can refer to [MaxiSys Ultra Tablet](#).

After that, you can tap **Diagnostics** or **Wheel alignment** from the main screen, and follow the screen step by step to enter the ADAS calibration section. To enter ADAS calibration section, please refer to [Advanced Wheel Alignment](#).

6.2 Adaptive Cruise Control

The ACC (Adaptive Cruise Control) system enables the driver to maintain a calibrated distance from the vehicle ahead, according to the distance and speed of the selected vehicle, the vehicle can realize automatic deceleration and acceleration.

NOTE

- Here we take Audi A7 2011 vehicle as an example for illustration, the calibration procedures may vary by vehicles. Please follow the specific instructions on your tablet.
 - Ensure there is a minimum area of 1.2 m (3.94 ft) in front of the vehicle.
-

6.2.1 Select a Situation That Needs Calibration

- Repaired or replaced the Adaptive Cruise Control (ACC) radar sensor control unit.
- The ACC radar sensor deviation angle is out of normal range.
- Adjusted the position of the ACC radar sensor on the vehicle body.
- Repaired or replaced the bumper or radiator grill.
- Adjusted the chassis.

6.2.2 Required Calibration Tools

- ✓ Calibration Frame AUTEL-CSC9000;
- ✓ Reflector AUTEL-CSC0602/01;
- ✓ Mini Reflector AUTEL-CSC0602/07;
- ✓ Wheel Clamp (Rim Clamp) AUTEL-CSC0500/19/LR;
- ✓ Wheel Clamp (Rim Clamp) AUTEL-CSC0500/19/RR;
- ✓ Target AUTEL-CSC0500/16/LR;
- ✓ Target AUTEL-CSC0500/16/RR;
- ✓ Distance Measuring Target AUTEL-CSC0500/08;
- ✓ Hex Wrench AUTEL-CSC0602/06 or Other Tools for Radar Adjustment (not included).

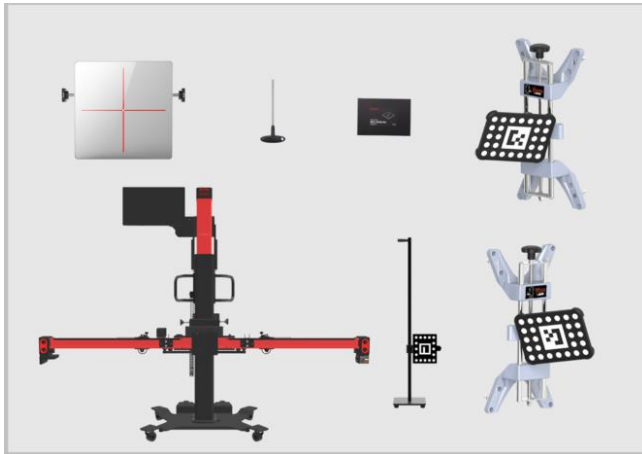

Figure 6-1 Required Calibration Tools

6.2.3 Calibration Preparations

NOTE

- Before calibration, check if the vehicle is equipped with Night Vision system;
 - If Night Vision system is equipped, use the MaxiSys ADAS diagnostic tablet to check if calibration is needed. If calibration is needed, follow the night vision system calibration instructions on the tablet to complete calibration;
 - If no night vision system is present or it does not need to be calibrated, perform ACC radar sensor calibration.
-

- Park the vehicle on a level surface. Center the steering wheel and keep the front wheels of the vehicle in a straight position (If necessary, perform the wheel alignment first). Ensure there is a minimum space of 3 m (118.11 in) in front of the vehicle;
 - Bring the vehicle to a complete stop, confirm the rear thrust angle is aligned and turn the ignition off;
 - Ensure the vehicle's coolant and engine oil are at recommended levels and the gas tank is full. The vehicle should not be carrying any additional load (such as passengers or cargo);
 - Attach the VCI to the vehicle and connect the diagnostic tool to the VCI (if the diagnostic tool and VCI are connected through diagnostic cable, guide the cable through window);
 - Close the vehicle doors and turn off all exterior lighting;
 - Adjust the tire pressure to the specified value;
 - If needed, connect the vehicle to a battery maintainer to prevent battery discharge;
 - For vehicles with air suspension, activate 'Jack Mode';
 - Generally, the ACC radar sensor is located on the grill under the vehicle emblem, or behind the vehicle emblem, or on either side of the bumper;
 - Remove the grill on the ACC radar sensor to check if the sensor is damaged or firmly attached. If it is damaged or not secure, repair or fix it;
 - Ensure the surface of the radar sensor is clean.
-

NOTE

- The actual location of the sensor varies by vehicle.
 - Tap **Video** to view a demonstration.
 - Tap **OK** to complete auxiliary tool placement.
 - Tap **Cancel** exit Adaptive Cruise Control (ACC) calibration.
-

6.2.4 Auxiliary Tool Positioning

➤ To position the sliding plate

1. Move the calibration frame to the level ground in front of the vehicle. If the pattern board has been installed onto the crossbar, remove it first.
2. Unfold both arms of the crossbar horizontally, and tighten the bolts (1) at the joints of the crossbar.
3. Hold the handles (2) on the sliding blocks, move the sliding blocks (3) on both sides to both ends and release the handle to fix the sliding blocks.
4. Hold the handle (4) on the sliding plate to move the sliding plate, so that the pointer on the sliding plate is aligned with the white mark line in position A, and then release the handle to fix the sliding plate.

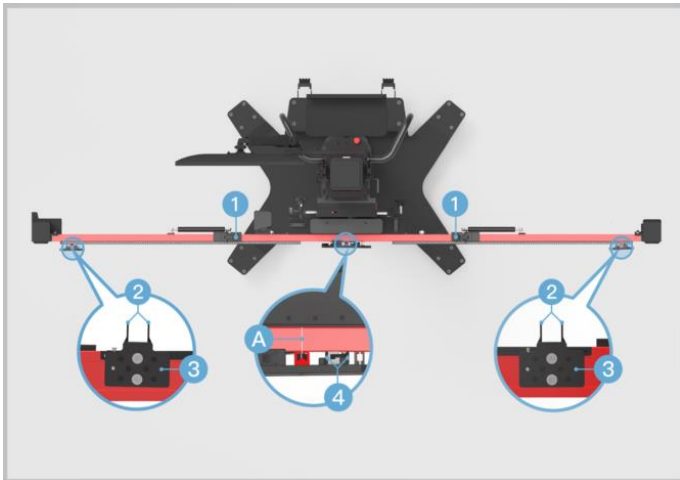

Figure 6-2 Position the Sliding Plate

➤ To align with marked lines and power on

1. Loosen the handle (1) and rotate the fine-tuning bolt (2) until the position A is aligned with the red mark line. Tighten the handle (1) to secure the crossbar.
2. Rotate the fine turning bolt (3) until the position B is aligned with the red mark line.
3. Rotate the fine-tuning bolt (4) until the position C is aligned with the white mark line. And rotate the fine-tuning bolt (5) until the position D is aligned with the white mark line.
4. Connect the power supply and then tun on the power switch (6).

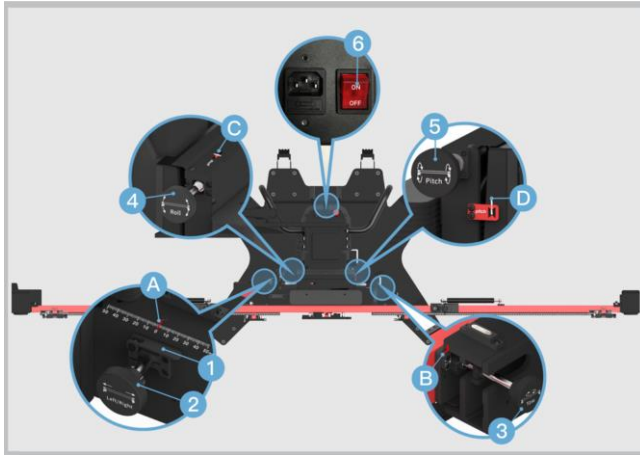

Figure 6-3 Align with Marked Lines

➤ **To center the laser at the front of the vehicle**

1. Place the calibration frame AUTEL-CSC9000 directly before the front center of the vehicle, and center the steering wheel.
2. Adjust the height of the crossbar by pressing **UP** and **DOWN** buttons on the back of the calibration frame, so that it is roughly at the same height as the center of the front wheel.
3. Hold the handle on the calibration frame and move the frame until the horizontal distances between the centers of front wheels and the back of the crossbar are roughly the same. Then turn on the laser (1) and the laser remains at the front center of the vehicle.

⚠ **NOTE**

Press the **EMERGENCY STOP** button to stop the lifting and lowering of the crossbar in emergency.

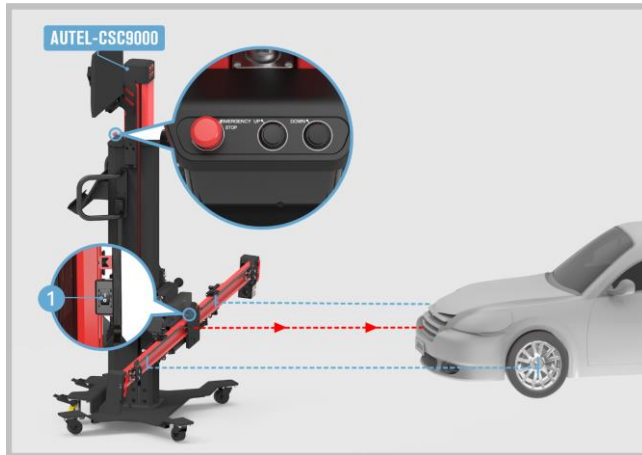

Figure 6-4 Center the Laser

➤ **To install the wheel clamps (rim clamps)**

1. Check the wheel clamp (rim clamp) AUTEL-CSC0500/19 and ensure its four pawls (2) are equal in length.
2. Attach the two wheel clamps (rim clamps) to the rear wheels respectively, and rotate the bolt (2) clockwise until the pawls (1) are tightly secured.

NOTE

Ensure the wheel clamps (rim clamps) are vertically installed on the rims, and the installation angle should be within -8° to 8° .

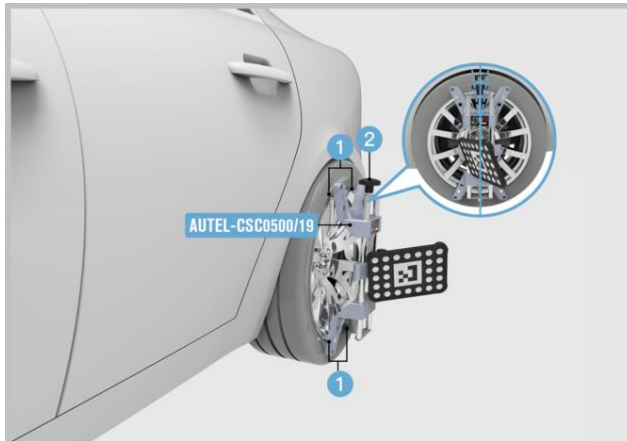

Figure 6-5 Install the Wheel Clamps (Rim Clamps)

➤ **To place and adjust the distance measuring target**

1. Place the distance measuring target AUTEL-CSC0500/08 in front of vehicle. Loosen the bolt (1) to adjust the height of the target so that it is roughly as the same height as the center of the license plate. Then tighten the bolt (1) to fix the target.
2. Move the distance measuring target to ensure the pointer (2) of the target touches the license plate and is aimed at the center of the license plate as precise as possible. Meanwhile, the white dotted side of the panel (3) faces the driving direction of the vehicle.

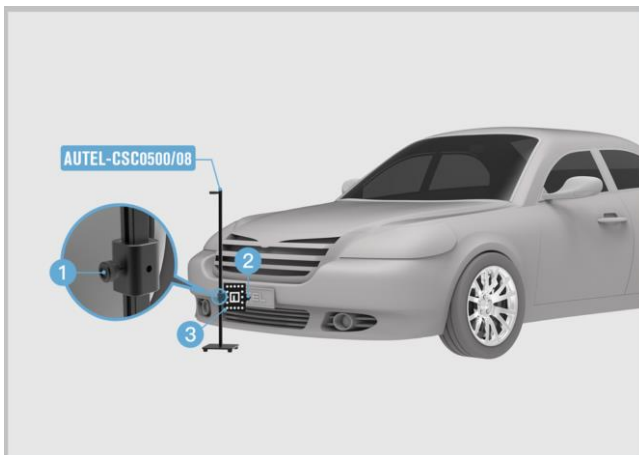

Figure 6-6 Adjust the Distance Measuring Target

NOTE

During the automatic adjustment, ensure there are no obstructions which may interface with the movement of the crossbar.

➤ **To adjust and fix the calibration frame**

NOTE

Once the position of distance measuring target has been obtained, a prompt of removing distance measuring target will display on the screen.

1. Positioning the ADAS calibration frame.

- Step 1 (Rough adjustment): hold the handle (A) on the calibration frame and move the calibration frame until the 'Distance' value is displayed in green and ensure the calibration frame and the vehicle are roughly aligned.
- Step 2 (Fine adjustment): rotate the fine-tuning bolt (D) until the 'Angle' value is displayed in green; loosen the handle (B) on the crossbar and rotate the fine-tuning bolt (C) according to the direction indicated by the arrow until the 'Offset' value is displayed in green, then tighten the handle (B) to secure the crossbar.
- Step 3 (Completion): the position adjustment of the ADAS calibration frame is completed.

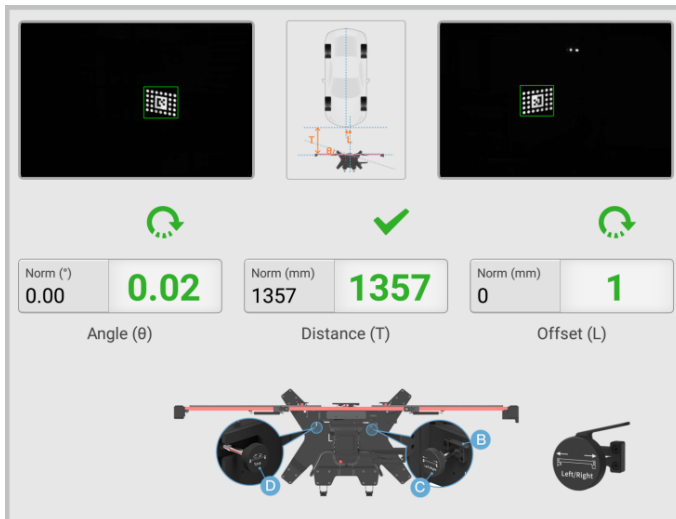

Figure 6-7 Adjust the Calibration Frame

2. After the placement of calibration frame, depress 2 brakes on the base to secure the calibration frame.

3. Turn off the sliding plate laser. Remove the wheel clamps (rim clamps) and targets.

➤ **To attach and adjust the reflector**

1. Fully attach the reflector AUTEL CSC0602/01 to the crossbar sliding plate.
2. Rotate the bolt (1) on the reflector so that the side labeled 2 is facing up.



Figure 6-8 Adjust the Reflector 1

3. Rotate the fine-tuning bolts (1) and (2) to ensure the bubble in the bubble level (3) of the reflector is centered.



Figure 6-9 Adjust the Reflector 2

NOTE

To make sure diagnosis is going on smoothly, please keep the diagnostic voltage higher than 12 V. If voltage is insufficient, please connect the device with battery charger.

➤ **To align the reflected laser with the origin laser**

1. Move the reflector AUTEL-CSC0602/01 left or right to aim the laser beam (2) at the mini reflector (3) on the radar sensor (on the right side of the vehicle's driving direction).
-

NOTE

- If the bubble in the bubble level deviates from the center during the adjustment, rotate the bolt on the base so that the bubble in the bubble level is centered.
 - The location of the mini reflector may vary by vehicle.
 - If there is no mini reflector on the sensor, attach the mini reflector AUTEL-CSC0602/07 on any flat place on the radar surface and aim the laser beam at this mini reflector.
-

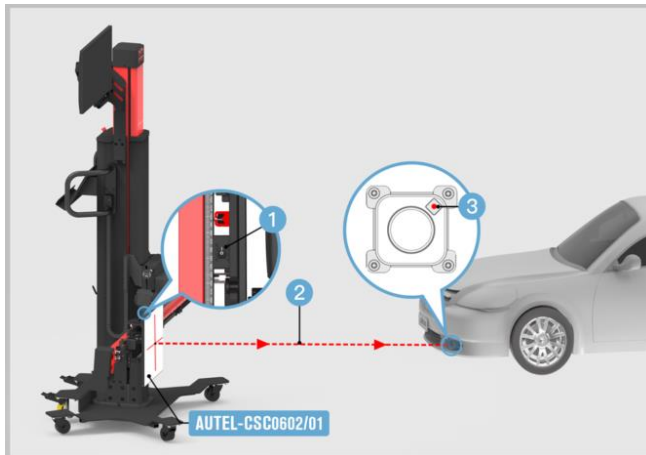

Figure 6-10 Align Laser with Mini Reflector

2. Use the hex wrench AUTEL-CSC0602/06 or other radar adjusters (not included) to adjust the sensor bolts (1) and (2) so that the reflected laser (3) aligns with the origin (4).

NOTE

The location of the adjusting bolt may vary by vehicle. Adjust the diagonal bolts until the reflected laser aligns with origin.

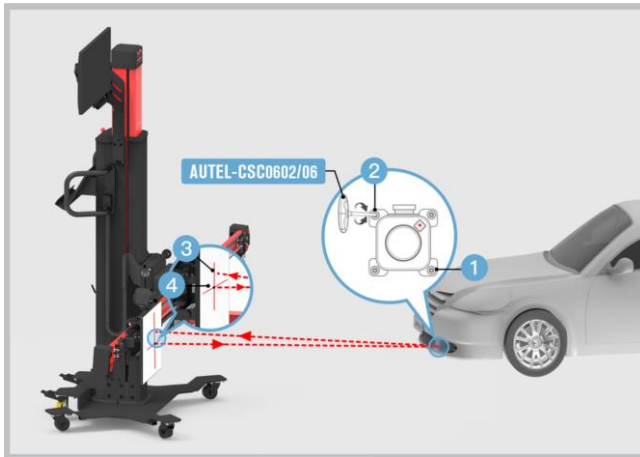

Figure 6-11 Align Reflector Laser with Origin Laser

➤ **To calibrate the left ACC radar sensor**

1. Turn on the sliding plate laser.
2. Adjust the height of the crossbar and move the reflector left or right to aim the laser beam at the center (1) of the radar sensor. Then turn off the sliding plate laser.

NOTE

If the bubble in the bubble level deviates from the center during the adjustment, rotate the bolt on the base so that the bubble in the bubble level is centered.

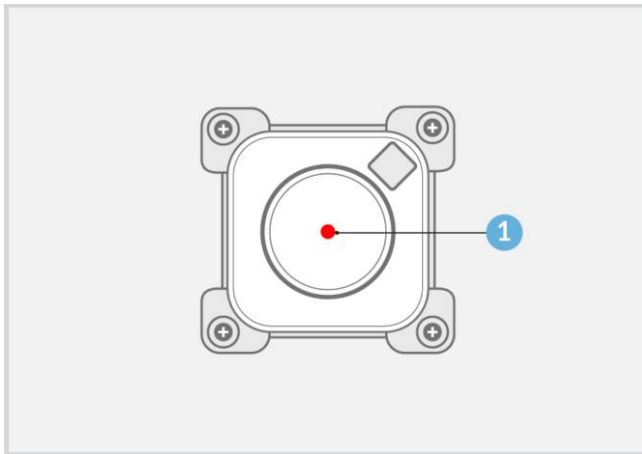

Figure 6-12 Center the Laser

3. Rotate the knob (A) on the reflector AUTEL-CSC0602/01 so that the side labeled 1 is facing up.

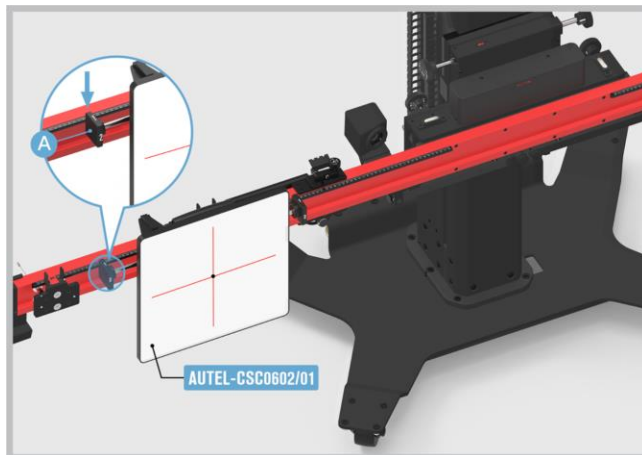

Figure 6-13 Adjust the Reflector 1

4. Rotate the knob (A) on the reflector AUTEL-CSC0602/01 so that the side labeled 2 is facing up.

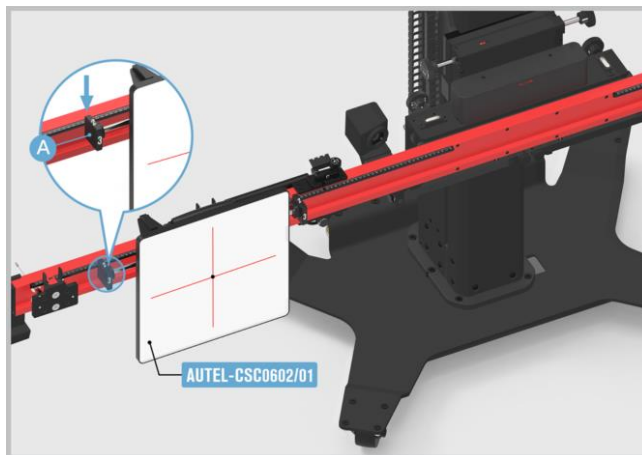

Figure 6-14 Adjust the Reflector 2

5. Rotate the knob (A) on the reflector AUTEL-CSC0602/01 so that the side labeled 3 is facing up.

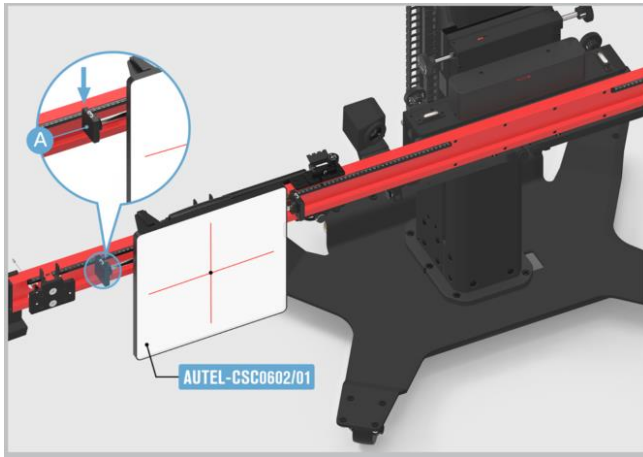

Figure 6-15 Adjust the Reflector 3

6. Wait until the screen displays that the distance regulation control module-J428 (Master) was successfully adjusted and the distance regulation control module 2-J850 (Slave) is adjusted. Then tap **OK** to continue.
7. Turn on the laser (1).
8. Adjust the height of the crossbar and move the reflector AUTEL-CSC0602/01 left or right to aim the laser beam (2) at the mini reflector (3) on the radar sensor (on the right side of the vehicle's driving direction).

NOTE

- If the bubble in the bubble level deviates from the center during the adjustment, rotate the bolt on the base so that the bubble in the bubble level is centered.
 - The location of the mini reflector may vary by vehicle.
 - If there is no mini reflector on the sensor, attach the mini reflector AUTEL-CSC0602/07 on any flat place on the radar surface and aim the laser beam at this mini reflector.
-

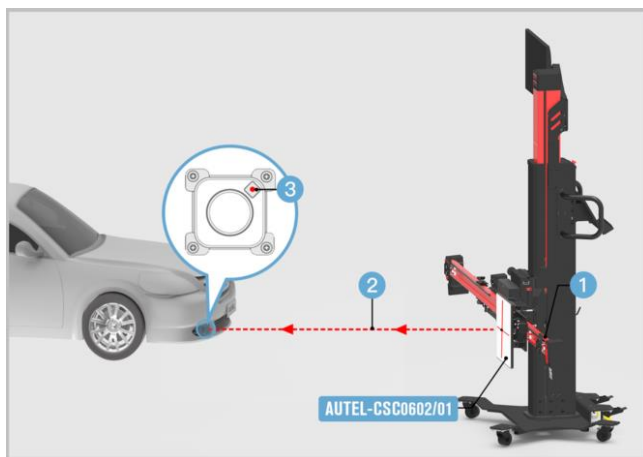

Figure 6-16 Align Laser with Mini Reflector

9. Use the hex wrench AUTEL-CSC0602/06 or other radar adjusters (not included) to adjust the sensor bolts (1) and (2) so that the reflected laser (3) aligns with the origin (4).

NOTE

The location of the adjusting bolt may vary by vehicle. Adjust the diagonal bolts until the reflected laser aligns with the origin.

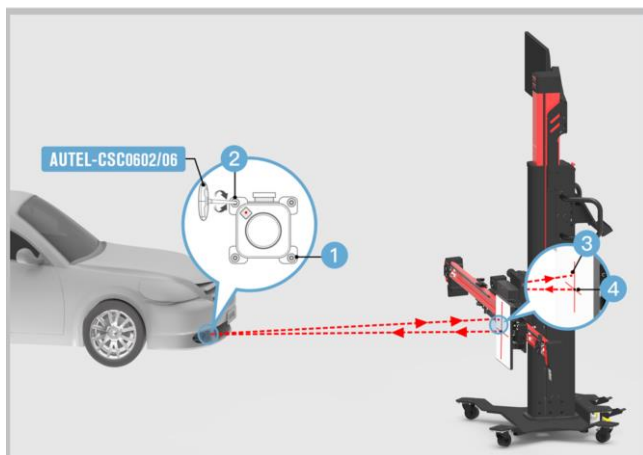

Figure 6-17 Align Reflected Laser with Origin Laser

➤ **To calibrate the right ACC radar sensor**

1. Adjust the height of the crossbar and move the reflector left or right to aim the laser beam at the center (1) of the radar sensor on the right side of the driving direction, and then turn off the sliding plate laser.

NOTE

If the bubble in the bubble level deviates from the center during the adjustment, rotate the bolt on the base so that the bubble in the bubble level is centered.

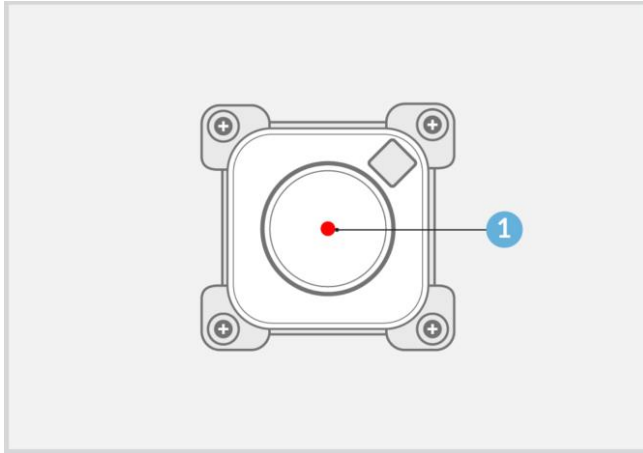

Figure 6-18 Center the Laser

2. Rotate the knob (A) on the reflector AUTEL-CSC0602/01 so that the side labeled 1 is facing up.

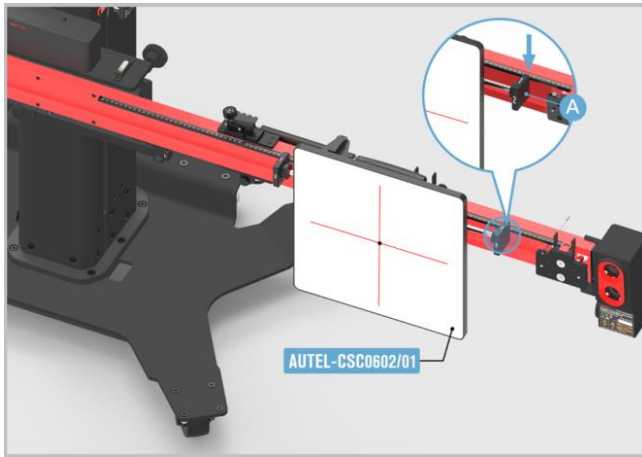

Figure 6-19 Adjust the Reflector 1

3. Rotate the knob (A) on the reflector AUTEL-CSC0602/01 so that the side labeled 2 is facing up.

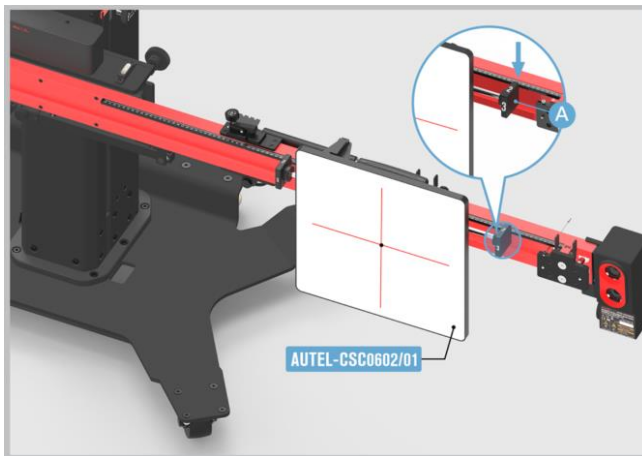

Figure 6-20 Adjust the Reflector 2

4. Rotate the knob (A) on the reflector AUTEL-CSC0602/01 so that the side labeled 3 is facing up.

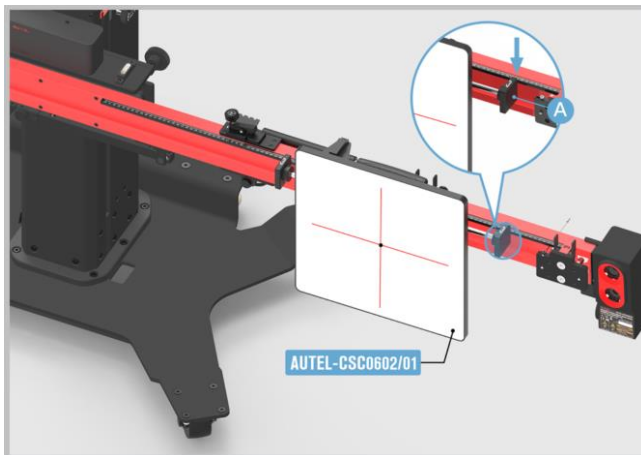

Figure 6-21 Adjust the Reflector 3

5. Wait until the screen displays that the distance regulation control module 2-J850 (Slave) was also successfully adjusted. The calibration is complete.

6.3 Lane Change Assistant

Since there is a visual blind spot in the rearview mirror of the vehicle, the vehicle in the blind spot cannot be seen before changing lanes. If there is an overtaking vehicle in the blind spot, a collision accident may occur when changing lanes. Blind spot detection system can sweep out the blind spot of the rearview mirror, so as to avoid accidents during lane changing.

NOTE

- Here we take Audi A7 2011 vehicle as an example for illustration, the calibration procedures may vary by vehicles. Please follow the specific instructions on your tablet.
- There is a minimum space of 2.4 m (7.87 ft) the rear wheel center to the rear.

6.3.1 Select a Situation That Needs Calibration

- Required or replaced the lane change assist control unit.
- Repaired or replaced the rear bumper hood/trunk.
- Adjusted the position of lane change assist control unit on the vehicle.

6.3.2 Select the Vehicle Parking Position

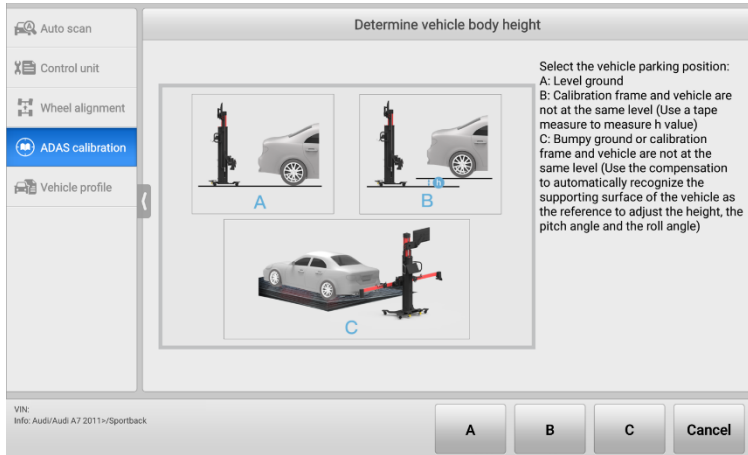

Figure 6-22 Select Vehicle Parking Position

- A: Level ground.
- B: Calibration frame and vehicle are not at the same level (use a tape measure to measure h value).

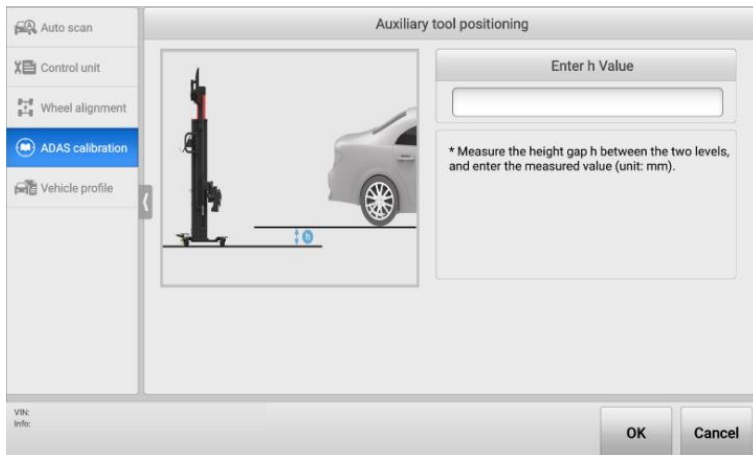

Figure 6-23 Measured Value h

- C: Bumpy ground or calibration frame and vehicle are not at the same level (use the compensation to automatically recognize the supporting surface of the vehicle as the reference to adjust the height, the pitch angle and the roll angle).

6.3.2.1 When Selecting A or B

1. Required Calibration Tools

- ✓ Calibration Frame AUTEL-CSC9000;
- ✓ Radar Calibration Box AUTEL-CSC0605/01;
- ✓ Wheel Clamp (Rim Clamp) AUTEL-CSC0500/19/LF;
- ✓ Wheel Clamp (Rim Clamp) AUTEL-CSC0500/19/RF;
- ✓ Target AUTEL-CSC0500/16/LF;
- ✓ Target AUTEL-CSC0500/16/RF;
- ✓ 24 V Power Adapter.



Figure 6-24 Required Calibration Tools (When Selecting A or B)

2. Calibration Preparations

- Park the vehicle on a level surface. Center the steering wheel, and keep the front wheels of the vehicle in a straight ahead position (If necessary, perform the wheel alignment first). Ensure there is a minimum space of 4 m (13.12 ft) * 4 m (13.12 ft) behind the vehicle (starting from the rear axle);
- For vehicles with air suspension, please set the chassis height as medium or automatic (shown on the instrument panel);
- Ensure the vehicle's coolant and engine oil are at recommended levels and the gas tank is full. The vehicle should not be carrying any additional load (such as passengers or cargo);

- Attach the VCI to the vehicle and connect the diagnostic tool to the VCI (If the diagnostic tool and VCI are connected through diagnostic cable, guide the cable through window);
 - Apply the parking brake and close all doors. No one should be inside the vehicle;
 - Adjust the tire pressure to the specified value;
 - If needed, remove the tinsel label on the bumper cover.
-

NOTE

- Do not open or close doors during calibration.
 - Tap **Video** to view a demonstration.
 - Tap **OK** to complete auxiliary tool placement.
 - Tap **Cancel** to exit Lane Change Assistant system calibration.
-

3. **Auxiliary Tool Positioning**

➤ **To position the sliding plate**

1. Move the calibration frame to the level ground behind the vehicle. If the pattern board has been installed onto the crossbar, remove it first.
2. Unfold the both arms of the crossbar horizontally, and tighten the bolts (1) at the joints of the crossbar.
3. Press and hold the handles (2) on the sliding blocks, move the sliding blocks (3) on both sides to both ends and release the handle to fix the sliding blocks.
4. Press and hold the handle (4) on the sliding plate to move the sliding plate, so that the pointer on the sliding plate is aligned with the white mark line in position A, and then release the handle to fix the sliding plate.

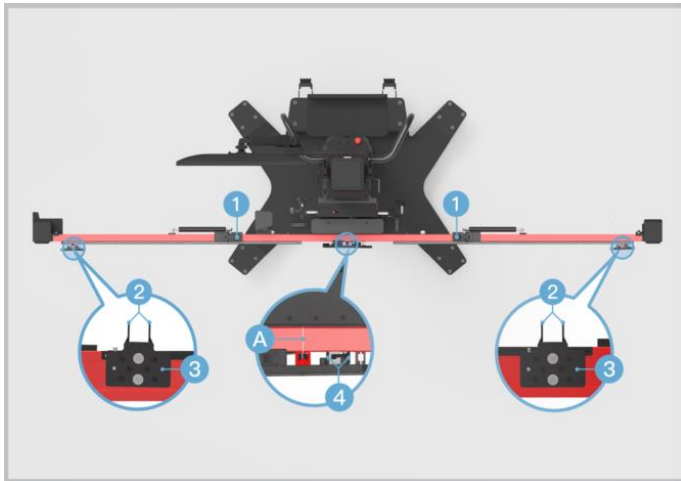

Figure 6-25 Position the Sliding Plate

➤ **To align with marked line and power on**

1. Loosen the handle (1) and rotate the fine-tuning bolt (2) until the position A is aligned with the red mark line. Tighten the handle (1) to secure the crossbar.
2. Rotate the fine turning bolt (3) until the position B is aligned with the red mark line.
3. Rotate the fine-tuning bolt (4) until the position C is aligned with the white mark line. And rotate the fine-tuning bolt (5) until the position D is aligned with the white mark line.
4. Connect the power supply and then turn on the power switch (6).

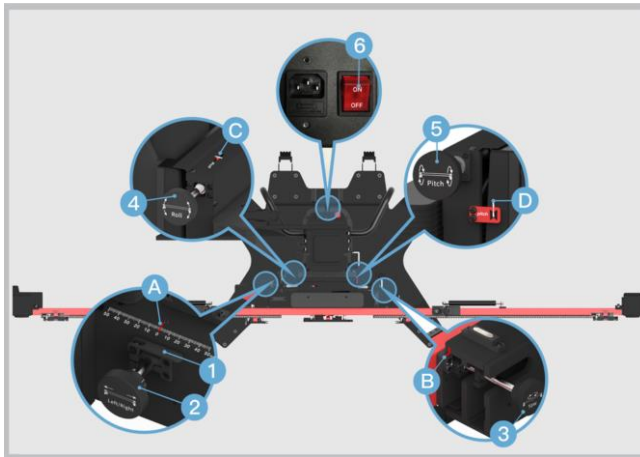

Figure 6-26 Align with Marked Lines

➤ **To center the laser at the rear of the vehicle**

1. Place the calibration frame AUTEL-CSC9000 directly behind the rear center of the vehicle.
2. Adjust the height of the crossbar by pressing **UP** and **DOWN** buttons on the back of the calibration frame, so that it is roughly at the same height as the center of the rear wheel.
3. Hold the handle on the calibration frame and move the frame until the horizontal distances between the centers of rear wheels and the back of the crossbar are roughly the same. Then turn on the laser (1) and the laser remains at the rear center of the vehicle.

🔗 **NOTE**

Press the **EMERGENCY STOP** button to stop the lifting and lowering of the crossbar in emergency.

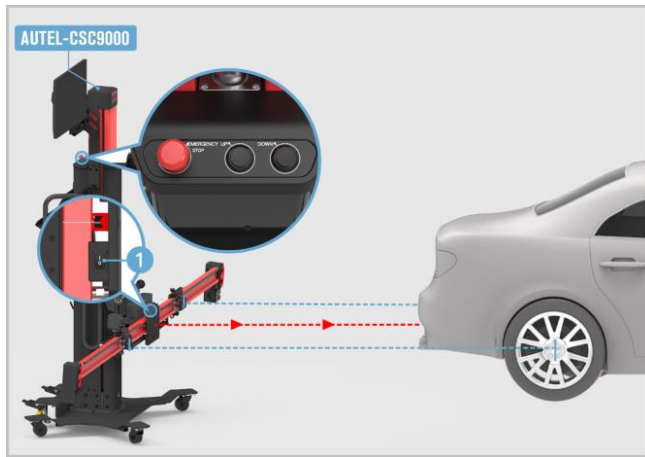

Figure 6-27 Center the Laser

➤ **To install the wheel clamps (rim clamps)**

1. Check the wheel clamp (rim clamp) AUTEL-CSC0500/19 and ensure its four pawls (2) are equal in length.
2. Attach the two wheel clamps (rim clamps) to the rear wheels respectively, and rotate the bolt (2) until the pawls (1) are tightly secured.

ⓘ **NOTE**

- The front wheel target AUTEL-CSC0500/16/LF should be installed on the right rear wheel, and the front wheel target AUTEL-CSC0500/16/RF should be installed on the left rear wheel;
 - Ensure the wheel clamps (rim clamps) are vertically installed on the rims, and the installation angle should be within -8° to 8° .
-

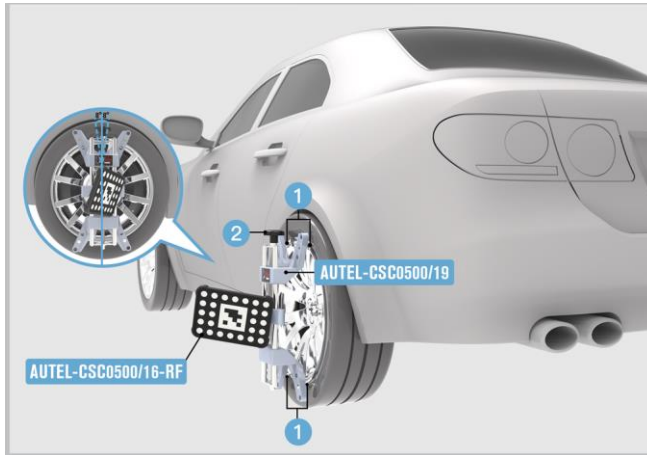

Figure 6-28 Install the Wheel Clamps (Rim Clamps)

NOTE

During the automatic adjustment, ensure there are no obstructions which may interface with the movement of the crossbar.

➤ **To adjust and fix the calibration frame**

1. Positioning the ADAS calibration frame.
 - Step 1 (Rough adjustment): hold the handle (A) on the calibration frame and move the calibration frame until the 'Distance' value is displayed in green and ensure the calibration frame and the vehicle are roughly aligned.
 - Step 2 (Fine adjustment): rotate the fine-tuning bolt (D) until the 'Angle' value is displayed in green; loosen the handle (B) on the crossbar and rotate the fine-tuning bolt (C) according to the direction indicated by the arrow until the 'Offset' value is displayed in green, then tighten the handle (B) to secure the crossbar.
 - Step 3 (Completion): the position adjustment of the ADAS calibration frame is completed.

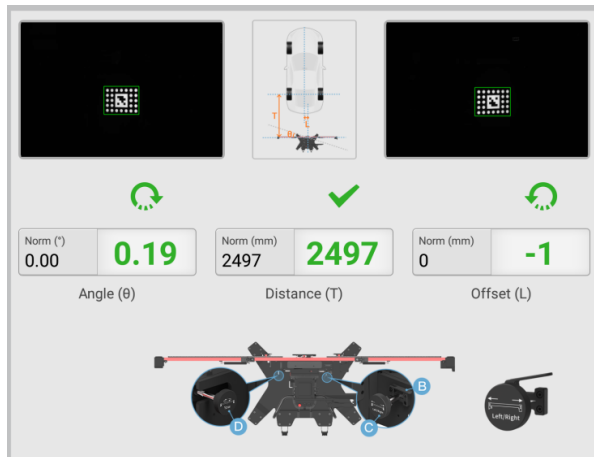

Figure 6-29 Position the Calibration Frame

2. After the placement of calibration frame, depress 2 brakes on the base to secure the calibration frame.
 3. Turn off the sliding plate laser. Remove the wheel clamps (rim clamps) and targets.
- **To center the bubble level of radar calibration box and power on**
1. Fully attach the radar calibration box AUTEL-CSC0605/01 onto the sliding plate.
 2. Rotate the fine-tuning bolts (1) and (2) so that the bubble in the bubble level (3) of radar calibration box is centered.

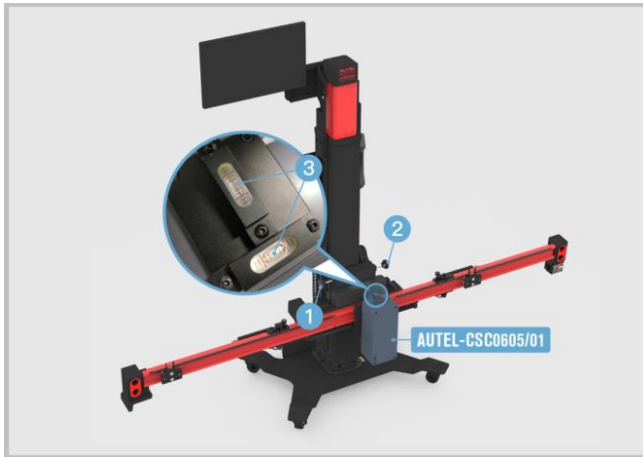

Figure 6-30 Center the Bubble Level of Radar Calibration Box

3. Plug the included power cord into the power port (1). Turn on the switch (Pos. 2) and the red LED (3) will light up. Do not go to the next step until approximately 10 s later when the green LED (4) lights up. There are two ways to connect the power supply:
 - ✧ Use the 24 V power adapter that can match the calibration frame.
 - ✧ Use the 24 V power cord equipped with the calibration frame.

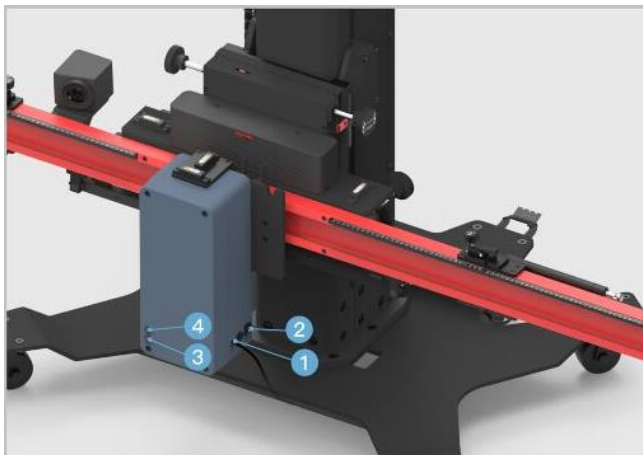

Figure 6-31 Connect Power

➤ **To adjust the standard height**

Adjust the crossbar height and wait for the crossbar to reach the standard height position:

1. Press **OK**, and the calibration frame will automatically adjust to the standard height and enter the next screen.
2. Press **Adjust Standard Height** to readjust the required height.

🔧 **NOTE**

During the automatic adjustment, ensure there are no obstructions which may interface with the movement of the crossbar.

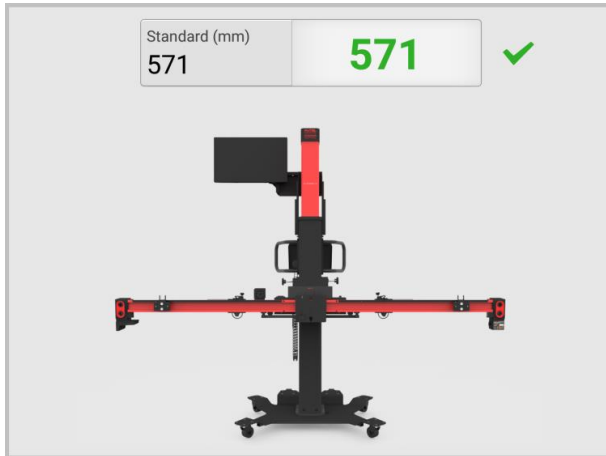

Figure 6-32 Adjust Standard Height

➤ **To calibrate the left control unit**

1. Move the radar calibration box AUTEL-CSC0605/01 to the left of the vehicle's driving direction, and aim the marked line (1) on the pointer (on the back of the crossbar sliding plate) at b=700 mm (27.56 in) on the crossbar ruler.

🔧 **NOTE**

If the bubble in the bubble level deviates from the center during the adjustment, rotate the bolt on the base so that the bubble in the bubble level is centered.

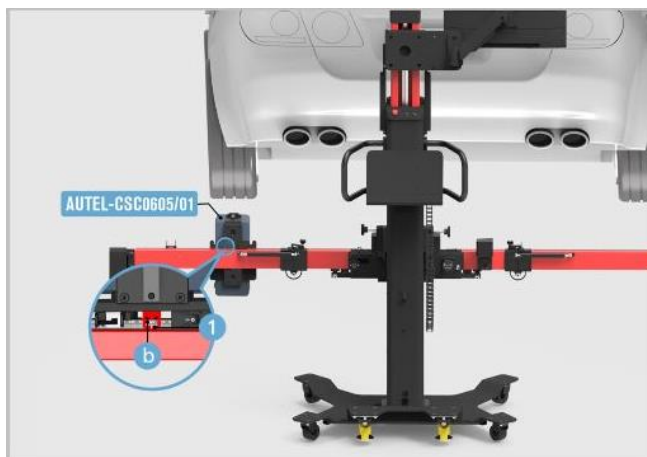

Figure 6-33 Move the Radar Calibration Box (Left)

2. Wait until the screen displays that the calibration in the Lane change assistant unit-J769 control unit was successful, and tap **OK** to enter the right control unit calibration.

➤ **To calibrate the right control unit**

1. Move the radar calibration box AUTEL-CSC0605/01 to the right of the vehicle's driving direction, and aim the marked line (1) on the pointer (on the back of the crossbar sliding plate) at $b=700$ mm (27.56 in) on the crossbar ruler.

ⓘ **NOTE**

If the bubble in the bubble level deviates from the center during the adjustment, rotate the bolt on the base so that the bubble in the bubble level is centered.

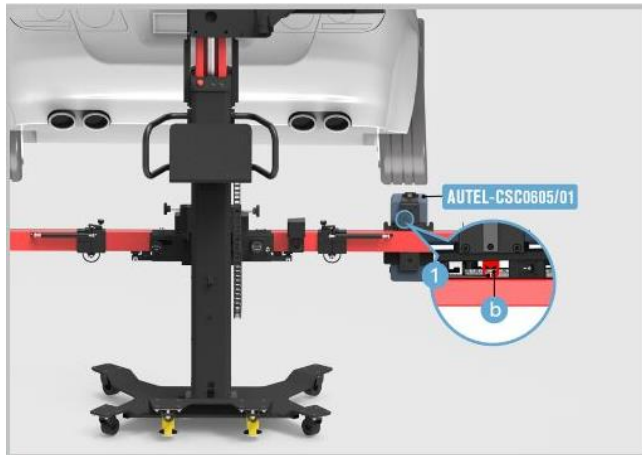

Figure 6-34 Move the Radar Calibration Box (Right)

2. Follow the on-screen instructions to operate step by step, and finally enter the screen displaying the calibration is successful.

6.3.2.2 When Selecting C

1. Required Calibration Tools

- ✓ Calibration Frame AUTEL-CSC9000;
- ✓ Radar Calibration Box AUTEL-CSC0605/01;
- ✓ Wheel Clamp (Rim Clamp) AUTEL-CSC0500/19/LF;
- ✓ Wheel Clamp (Rim Clamp) AUTEL-CSC0500/19/RF;
- ✓ Wheel Clamp (Rim Clamp) AUTEL-CSC0500/19/LR;
- ✓ Wheel Clamp (Rim Clamp) AUTEL-CSC0500/19/RR;
- ✓ Target AUTEL-CSC0500/16/LF;
- ✓ Target AUTEL-CSC0500/16/RF;
- ✓ Target AUTEL-CSC0500/16/LR;
- ✓ Target AUTEL-CSC0500/16/RR;
- ✓ 24 V Power Adapter;
- ✓ Steering Wheel Holder Stand Tool;
- ✓ Wheel Chock.

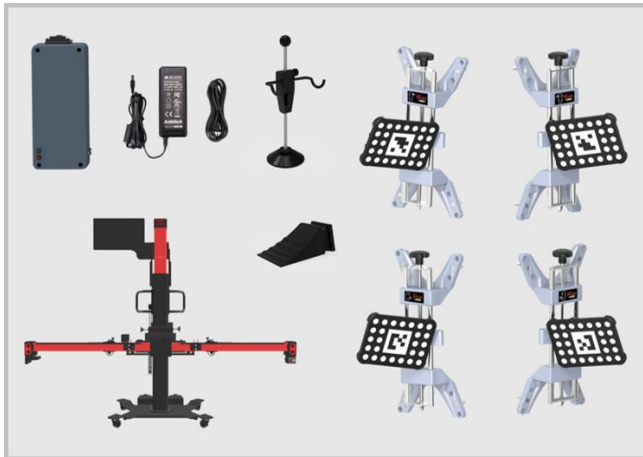

Figure 6-35 Required Calibration Tools (When Selecting C)

2. Calibration Preparations

- Park the vehicle on a level surface. Center the steering wheel, and keep the front wheels of the vehicle in a straight ahead position (If necessary, perform the wheel alignment first). Ensure there is a minimum space of 4 m (13.12 ft) * 4 m (13.12 ft) behind the vehicle (starting from the rear axle);
- For vehicles with air suspension, please set the chassis height as medium or automatic (shown on the instrument panel);
- Ensure the vehicle's coolant and engine oil are at recommended levels and the gas tank is full. The vehicle should not be carrying any additional load (such as passengers or cargo);
- Attach the VCI to the vehicle and connect the diagnostic tool to the VCI (If the diagnostic tool and VCI are connected through diagnostic cable, guide the cable through window);
- Apply the parking brake and close all doors. No one should be inside the vehicle;
- Adjust the tire pressure to the specified value;
- If needed, remove the tinsel label on the bumper cover.

NOTE

- Do not open or close doors during calibration.
 - Tap **Video** to view a demonstration.
 - Tap **OK** to complete auxiliary tool placement.
 - Tap **Cancel** to exit Blind Spot Detection (BSD) system calibration.
-

3. **Vehicle Preparation**

- Park the vehicle on a level surface. Keep the front wheels straight ahead and ensure there are enough space within 1.5 m or more at the rear of the vehicle;
- Place a wheel chock separately at the front and rear of the left front wheel or the right front wheel to prevent movement;
- Center the steering wheel and install the steering wheel holder stand tool. Release the parking brake and place the transmission in neutral;
- Keep the vehicle unladen. Ensure that the coolant and engine oil are at recommended levels and the fuel tank is full.
- Close all doors and turn off all external lighting;
- Adjust the tire pressure to the specified value;
- For vehicles equipped with air suspension, set the air suspension to the standard mode before performing the measurement (this adjustment process may vary on different vehicle models).

4. **Auxiliary Tool Positioning**

➤ **To position the sliding plate**

1. Move the calibration frame to the level ground behind the vehicle. If the pattern board has been installed onto the crossbar, remove it first.
2. Unfold the both arms of the crossbar horizontally, and tighten the bolts (1) at the joints of the crossbar.
3. Press and hold the handles (2) on the sliding blocks, move the sliding blocks (3) on both sides to both ends and release the handle to fix the sliding blocks.
4. Press and hold the handle (4) on the sliding plate to move the sliding plate, so that the pointer on the sliding plate is aligned with the white mark line in position A, and then release the handle to fix the sliding plate.

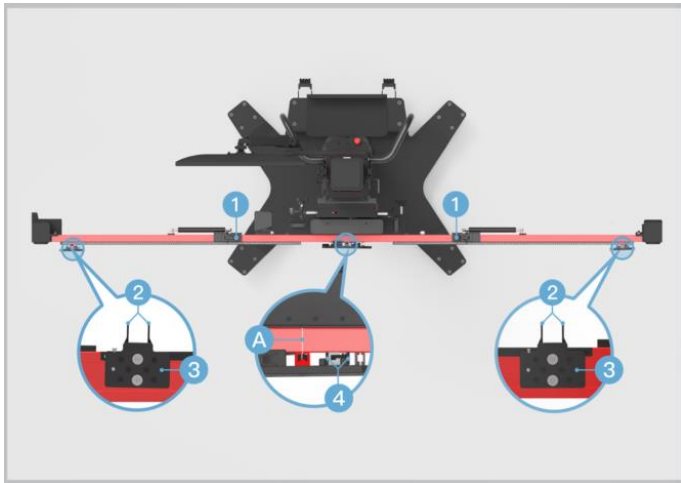

Figure 6-36 Position the Sliding Plate

➤ **To align with marked line and power on**

1. Loosen the handle (1) on the crossbar, and then rotate the fine-tuning bolt (2) until the position A is aligned with the red mark line. Tighten the handle (1) to secure the crossbar.
2. Rotate the fine turning bolt (3) until the position B is aligned with the red mark line.
3. Rotate the fine-tuning bolt (4) until the position C is aligned with the white mark line. And rotate the fine-tuning bolt (5) until the position D is aligned with the white mark line.
4. Connect the 220 V power, and then turn on the power switch (6).

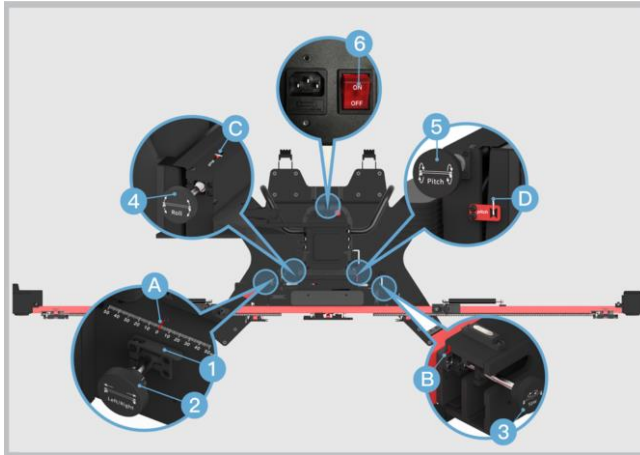

Figure 6-37 Align with Marked Lines

➤ **To center the laser at the rear of the vehicle**

1. Place the calibration frame AUTEL-CSC9000 directly behind the rear center of the vehicle.
2. Adjust the height of the crossbar by pressing **UP and DOWN** buttons on the back of the calibration frame, so that it is roughly at the same height as the center of the rear wheel.
3. Hold the handle on the calibration frame and move the frame until the horizontal distances between the centers of rear wheels and the back of the crossbar are roughly the same. Then turn on the sliding plate laser (1) and the laser remains at the rear center of the vehicle.

ⓘ **NOTE**

Press the **EMERGENCY STOP** button to stop the lifting and lowering of the crossbar in emergency.

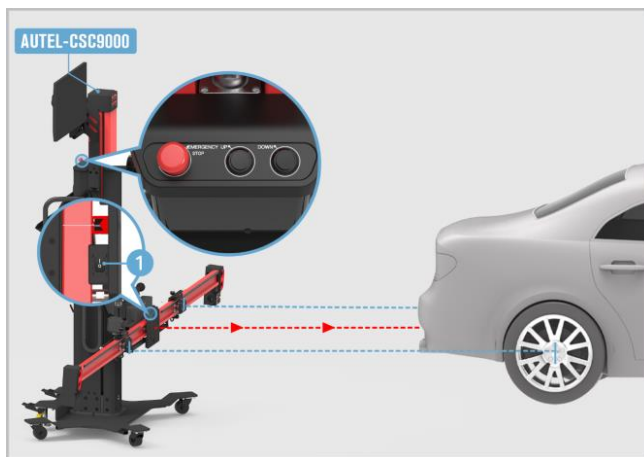

Figure 6-38 Center the Laser

➤ **To install the wheel clamps (rim clamps)**

1. Check the wheel clamp (rim clamp) AUTEL-CSC0500/19 and ensure its four pawls (1) are equal in length.
2. Install four wheel clamp (rim clamp) pawls to the rims, and tighten the bolt (2) until the pawls (1) are tightly secured.

NOTE

- Ensure that the installation holes of four wheel clamp (rim clamp) pawls are in the same order from inside to outside;
 - The front wheel target AUTEL-CSC0500/16/LF should be installed on the right rear wheel, and the front wheel target AUTEL-CSC0500/16/LR should be installed on the left rear wheel;
 - The rear wheel target AUTEL-CSC0500/16/RF should be installed on the right front wheel, and the rear wheel target AUTEL-CSC0500/16/RR should be installed on the left front wheel;
 - Ensure the wheel clamps (rim clamps) are vertically installed on the rims, and the installation angle should be within -8° to 8° .
-

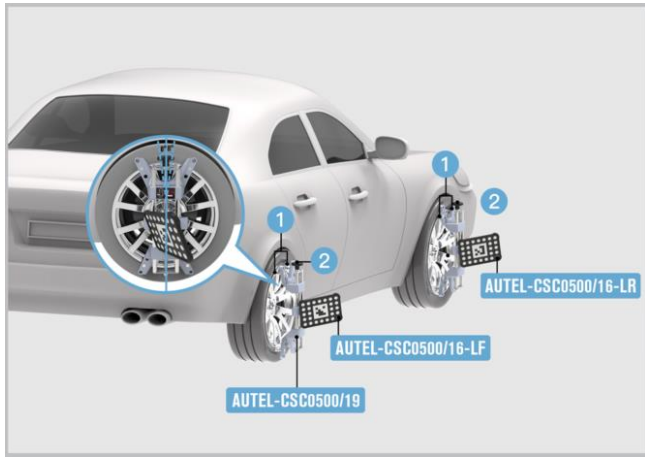

Figure 6-39 Install Wheel Clamps (Rim Clamps)

➤ **To perform wheel rolling compensation**

1. As shown in the screen guides, move the wheel chock backward for about 30 cm, and then push the vehicle in the direction indicated by the arrow.

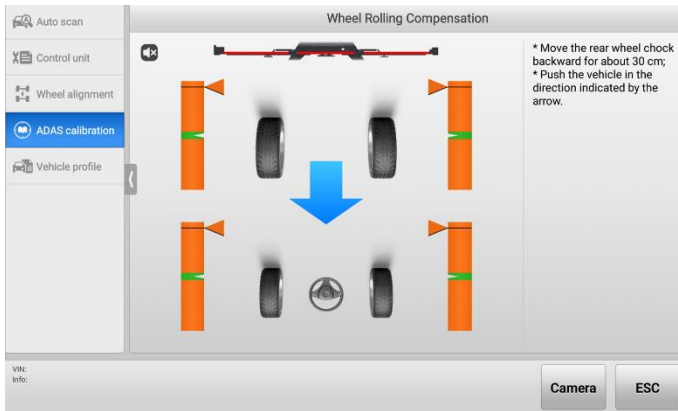

Figure 6-40 Wheel Rolling Compensation 1

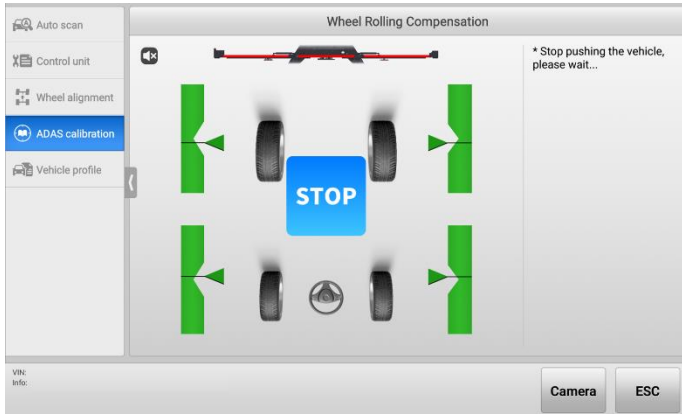

Figure 6-41 Wheel Rolling Compensation 2

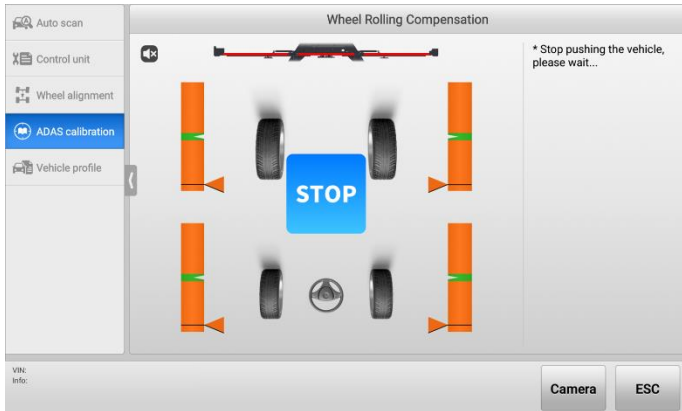

Figure 6-42 Wheel Rolling Compensation 3

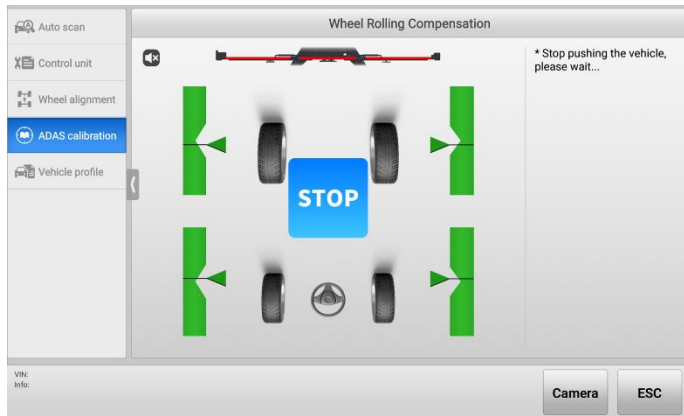

Figure 6-43 Wheel Rolling Compensation 4

2. If the rolling compensation is completed, the tablet will enter the next screen automatically.

NOTE

During the automatic adjustment, ensure there are no obstructions which may interface with the movement of the crossbar.

➤ **To adjust and fix the calibration frame**

1. Positioning the ADAS calibration frame.
 - Step 1 (Rough adjustment): hold the handle (A) on the calibration frame and move the calibration frame until the 'Distance' value is displayed in green and ensure the calibration frame and the vehicle are roughly aligned.
 - Step 2 (Fine adjustment): rotate the fine-tuning bolt (D) until the 'Angle' value is displayed in green; loosen the handle (B) on the crossbar and rotate the fine-tuning bolt (C) according to the direction indicated by the arrow until the 'Offset' value is displayed in green, then tighten the handle (B) to secure the crossbar.
 - Step 3 (Completion): the position adjustment of the ADAS calibration frame is completed.

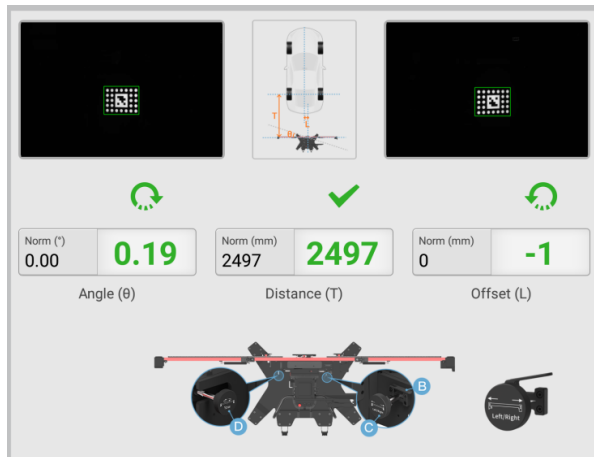

Figure 6-44 Position the Calibration Frame

2. After the placement of calibration frame, depress 2 brakes on the base to secure the calibration frame.
 3. Turn off the sliding plate laser. Remove the wheel clamps (rim clamps) and targets.
- **To center the bubble level of radar calibration box and power on**
1. Fully attach the radar calibration box AUTEL-CSC0605/01 onto the sliding plate.
 2. Rotate the fine-tuning bolts (1) and (2) so that the bubble in the bubble level (3) of radar calibration box is centered.

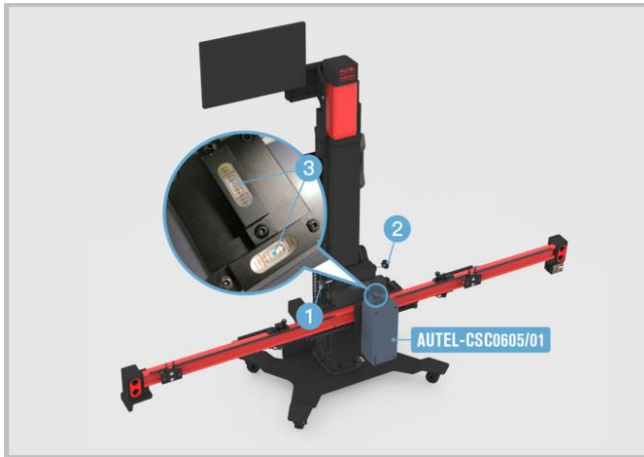

Figure 6-45 Center the Bubble Level of Radar Calibration Box

3. Plug the included power cord into the power port (1). Turn on the switch (Pos. 2) and the red LED (3) will light up. Do not go to the next step until approximately 10 s later when the green LED (4) lights up. There are two ways to connect the power supply:
 - ✧ Use the 24 V power adapter that can match the calibration frame.
 - ✧ Use the 24 V power cord equipped with the calibration frame.

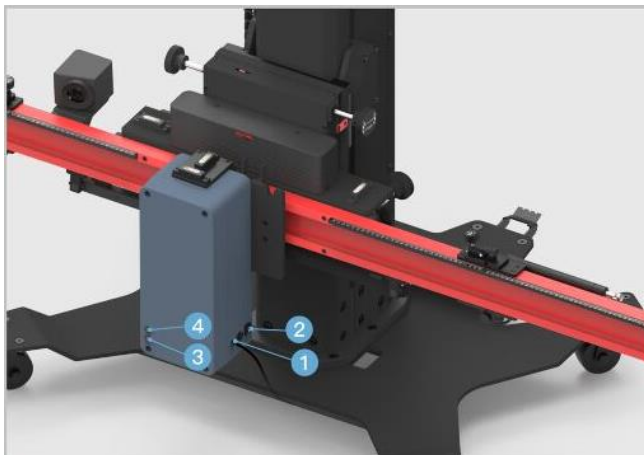

Figure 6-46 Connect Power

➤ **To adjust the standard height**

Adjust the crossbar height and wait for the crossbar to reach the standard height position:

1. Tap **OK**. The calibration frame will automatically adjust to the standard height and enter the next screen.
2. Tap **Adjust Standard Height** to readjust the required height.

 **NOTE**

During the automatic adjustment, ensure there are no obstructions which may interface with the movement of the crossbar.

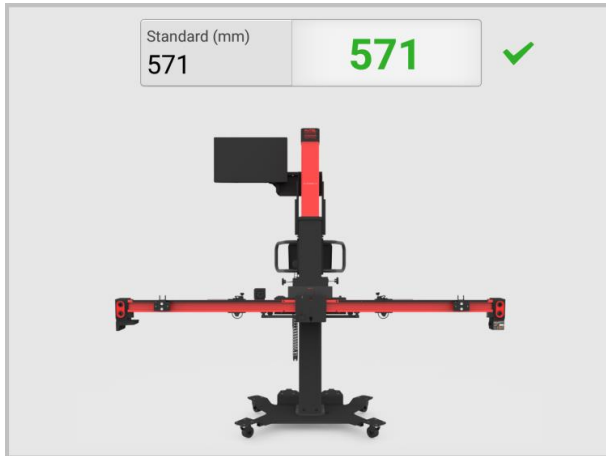

Figure 6-47 Adjust Standard Height

➤ **To calibrate the left control unit**

1. Move the radar calibration box AUTEL-CSC0605/01 to the left of the vehicle's driving direction, and aim the marked line (1) on the pointer (on the back of the crossbar sliding plate) at b=700 mm (27.56 in) on the crossbar ruler.

 **NOTE**

If the bubble in the bubble level deviates from the center during the adjustment, rotate the bolt on the base so that the bubble in the bubble level is centered.

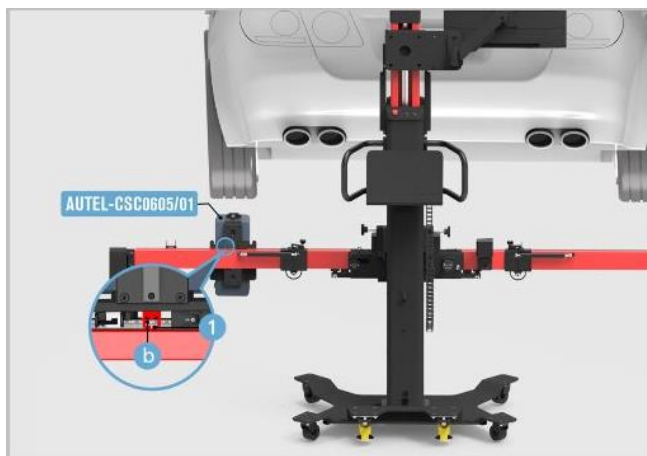

Figure 6-48 Move the Radar Calibration Box (Left)

2. Wait until the screen displays that the calibration in the Lane change assistant unit-J769 control unit was successful, and tap **OK** to enter the right control unit calibration.

➤ **To calibrate the right control unit**

1. Move the radar calibration box AUTEL-CSC0605/01 to the right of the vehicle's driving direction, and aim the marked line (1) on the pointer (on the back of the crossbar sliding plate) at $b=700$ mm (27.56 in) on the crossbar ruler.

ⓘ **NOTE**

If the bubble in the bubble level deviates from the center during the adjustment, rotate the bolt on the base so that the bubble in the bubble level is centered.



Figure 6-49 Move the Radar Calibration Box (Right)

2. Wait until the screen displays that the Lane change assistant control unit-J769 and Lane change assistant control unit 2-J770 were successfully calibrated. Then tap **OK** to complete the calibration.

6.4 Camera System Rear View

The panoramic camera system, having cameras for providing a secure 360° view, can transmit the images around to the cab in real time, so that the driver can accurately grasp the environmental conditions at close range.

NOTE

Here we take Audi A7 2011 vehicle as an example for illustration, the calibration procedures may vary by vehicles. Please follow the specific instructions on your tablet.

6.4.1 Select a Situation That Needs Calibration

- Replaced the panoramic camera.
- Replaced the panoramic camera system control unit.
- Repaired the components that are equipped with panoramic camera or affect camera installation.
- Adjusted the chassis.
- Overlapped areas of images shot by panoramic cameras are dislocated.
- Adjusted the vehicle body height.
- Adjusted the position of panoramic camera on vehicle body.

6.4.2 Required Calibration Tools

- ✓ Pattern AUTEL-CSC0806/01;
- ✓ Laser AUTEL-CSC0500/04;
- ✓ Target Board (x2) AUTEL-CSC0804/01;
- ✓ Target Board Holder (x2) AUTEL-CSC0804/02;
- ✓ Tape Measure.

6.4.3 Calibration Preparations

- Park the vehicle on a level surface. Center the steering wheel, and keep the front wheels of the vehicle in a straight ahead position (If necessary, perform the wheel alignment first). Ensure there is a room around the vehicle;
- Extend the exterior rear view mirrors on both side of the vehicle;
- Ensure all camera lenses are clean. If needed, clean lenses with damp cloth;
- Check the respective camera images on the central console display. Replace the camera if the image is affected due to camera damage; check and correct the respective camera position if the image is at an angle;
- Ensure the vehicle's coolant and engine oil are at recommended levels and the gas tank is full. The vehicle should not be carrying any additional load (such as passengers or cargo);
- Attach the VCI to the vehicle and connect the diagnostic tool to the VCI (If the diagnostic tool and VCI are connected through diagnostic cable, guide the cable through window);
- Apply the parking brake and close all doors, hood and trunk;
- Adjust the tire pressure to the recommended placard value;
- Set the ride setting to 'Comfort';
- Set the chassis height to 'Normal', and then set it to 'Jack Mode' by selecting 'Jack Mode' (the level adjustment function is turned off);
- If needed, connect the vehicle to a battery maintainer to prevent battery discharge;
- Turn on ignition;
- Ensure no one is inside the vehicle during calibration;
- To avoid recognition error, ensure there are no objects surrounding the calibration area;

- Ensure the calibration area is well lit.

NOTE

Do not open or close doors during calibration.

6.4.4 Auxiliary Tool Positioning

- **To mount the target board**

1. Assemble two sets of calibration tools. Place the target board holder AUTEL-CSC0804/02 on a level surface.
2. Mount the target board AUTEL-CSC0804/01 onto the hook (1) on the top of the target board holder.

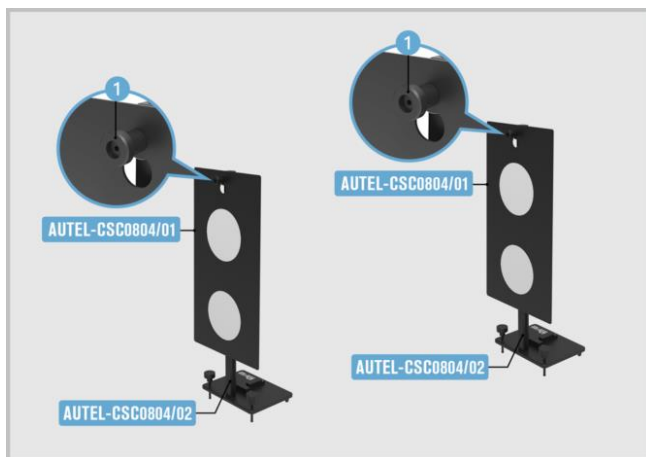

Figure 6-50 Mount the Target Board

NOTE

Ensure the ignition is on.

- **To calibrate the camera front**

1. Lay the pattern AUTEL-CSC0806/01 directly in front of the vehicle, measure the distance ($B=4.2$ m (13.80 ft)) between the center of the rear wheels and the marked line (1). Ensure the distances on both sides are the same.
2. Place the laser AUTEL-CSC0500/04 in the position displayed in the figure and turn on the laser. Align the marked line (2) on the back of the laser and laser beam (3) with the marked lines (4) and (5) on the pattern respectively.
3. Move the pattern AUTEL-CSC0806/01 left or right to aim the laser beam (3) at the center of the vehicle emblem. Turn off the laser and store it.

NOTE

- Ensure the pattern AUTEL-CSC0806/01 is placed correctly and its surface lies flat and reflects no light.
- Ensure the position of the laser does not change when moving the pattern.

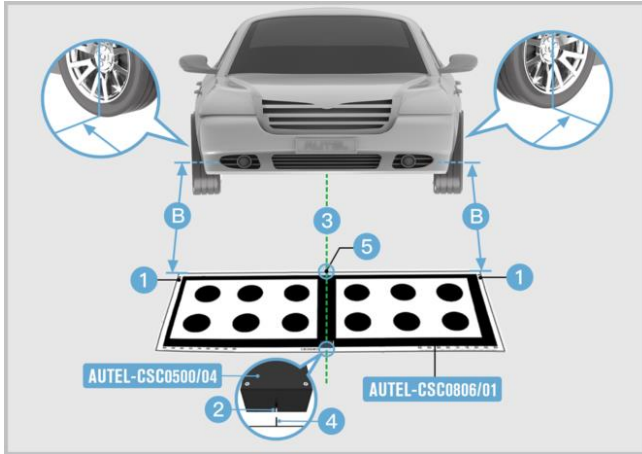

Figure 6-51 Calibrate Camera Front 1

4. Place the two assembled calibration toolsets in the position displayed in the figure. Ensure the side (1) with marked line on the base of the target board holder attaches with the edge of ruler (2) on the pattern.
5. Move the target board holder left or right to aim the marked line (3) at 775 on the ruler (2).
6. Rotate the bolts (4) and (5) so that the bubbles in the bubble levels (6) and (7) is centered.

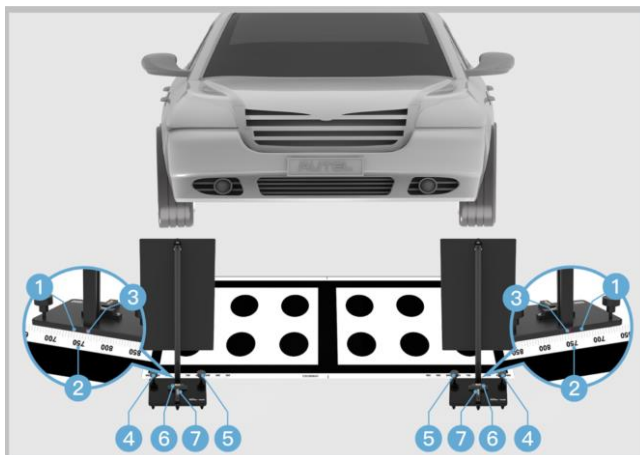

Figure 6-52 Calibrate Camera Front 2

➤ **To calibrate the camera rear**

1. Lay the pattern AUTEL-CSC0806/01 directly behind the vehicle, measure the distance between the center of the rear wheels ($B=1.47\text{ m} - 1.90\text{ m}$ (4.82 ft – 6.23 ft)) and the marked line (1). Ensure the distances on both sides are the same.
2. Place the laser AUTEL-CSC0500/04 in the position displayed in the figure and turn on the laser. Align the marked line (2) on the back of the laser and laser beam (3) with the marked lines (4) and (5) on the pattern respectively.
3. Move the pattern AUTEL-CSC0806/01 left or right to aim the laser beam (3) at the center of the vehicle emblem. Turn off the laser and store it.

NOTE

- Ensure the pattern AUTEL-CSC0806/01 is placed correctly and its surface lies flat and reflects no light;
- Ensure the position of the laser does not change when moving the pattern.

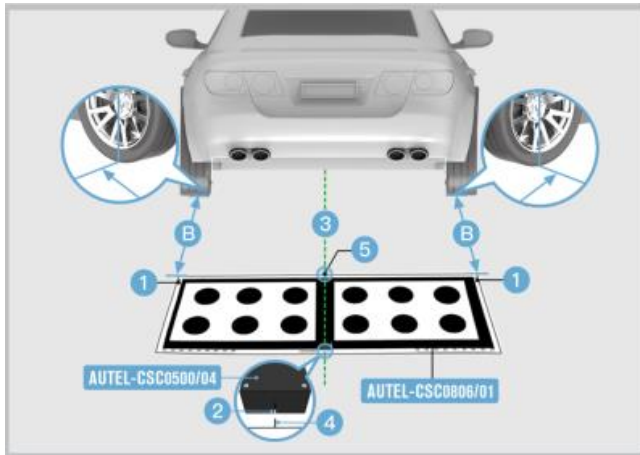

Figure 6-53 Calibrate Camera Rear 1

4. Place the two assembled calibration toolsets in the position displayed in the figure. Ensure the side (1) with marked line on the base of the target board holder attaches with the edge of the ruler (2) on the pattern.
5. Move the target board holder left or right to aim the marked line (3) at 775 on the ruler (2).
6. Rotate the bolts (4) and (5) so that the bubbles in the bubble levels (6) and (7) is centered.

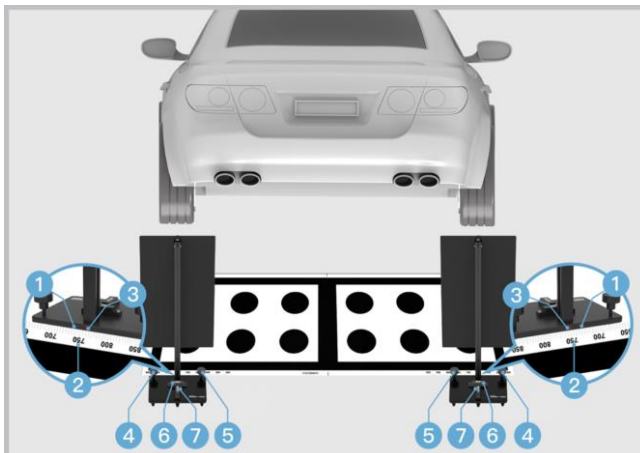

Figure 6-54 Calibrate Camera Rear 2

7. Measure the distance A between pattern marked line (1) and the center of the rear wheel and input it into the diagnostic tablet.

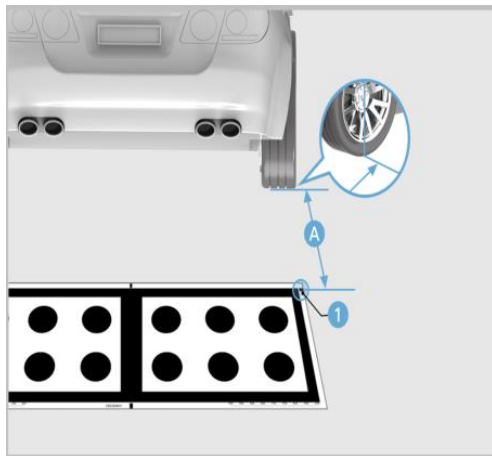

Figure 6-55 Calibrate Camera Rear 3

➤ **To calibrate the camera in left mirror**

1. Lay the pattern AUTEL-CSC0806/01 on the left side of the vehicle (subject to the driving direction of the vehicle). Ensure the black edge (1) aligns with the center of the front wheel.
2. Ensure edge (2) of the pattern parallels with the vehicle body, and the distance between the edge (2) and the front wheel (B) is $B=150\text{ mm (5.91 in) - 200 mm (7.87 in)}$.

NOTE

Ensure the pattern AUTEL-CSC0806/01 is placed correctly so that the long side without scale is next to the vehicle and the surface lies flat and reflects no light.

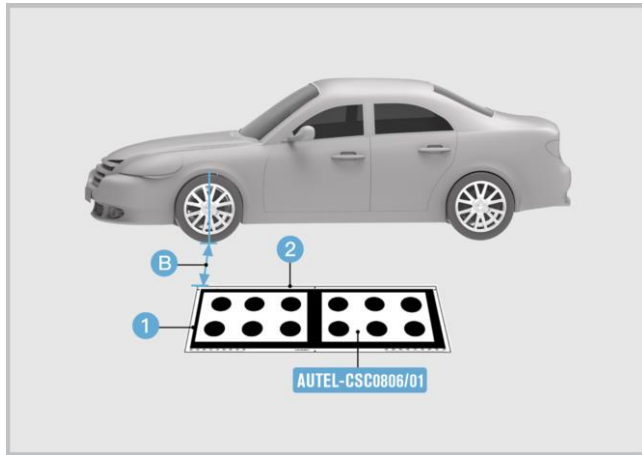

Figure 6-56 Calibrate Camera in Left Mirror 1

3. Place the two assembled calibration toolsets in the position displayed in the figure. Ensure the side (1) with a marked line on the base of the target board holder attaches with the edge of the ruler (2) on the pattern.
4. Move the target board holder left or right to aim the marked line (3) at 775 on the ruler (2).
5. Rotate the bolts (4) and (5) so that the bubbles in the bubble levels (6) and (7) is centered.

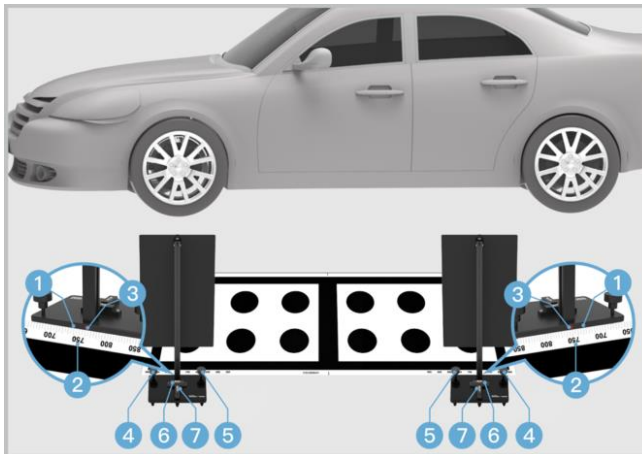

Figure 6-57 Calibrate Camera in Left Mirror 2

➤ **To calibrate the camera in right mirror**

1. Lay the pattern AUTEL-CSC0806/01 on the right side of the vehicle (subject to the driving direction of the vehicle). Ensure the back edge (1) aligns with the center of the front wheel.
2. Ensure edge (2) of the pattern parallels with the vehicle body, and the distance between the edge (2) and the front wheel (B) is $B=150\text{ mm (5.91 in) - }200\text{ mm (7.87 in)}$.

NOTE

Ensure the pattern AUTEL-CSC0806/01 is placed correctly so that the long side without scale is next to the vehicle and the surface lies flat and reflects no light.

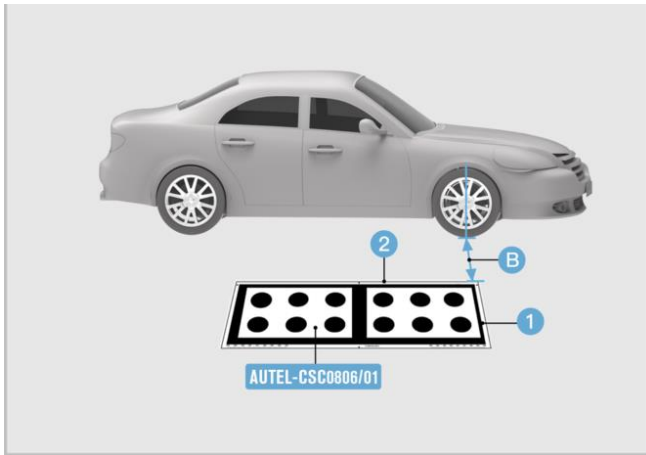

Figure 6-58 Calibrate Camera in Right Mirror 1

3. Place the two assembled calibration toolsets in the position displayed in the figure. Ensure the side (1) with a marked line on the base of the target board holder attaches with the edge of the ruler (2) on the pattern.
4. Move the target board holder left or right to aim the marked line (3) at 775 on the ruler (2).
5. Rotate the bolts (4) and (5) so that the bubbles in the bubble levels (6) and (7) is centered.

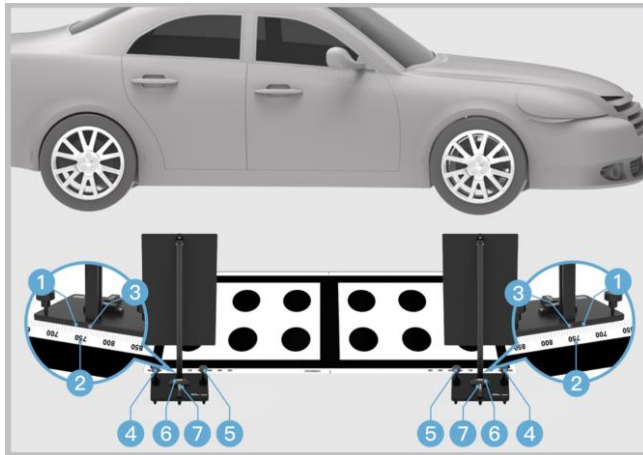

Figure 6-59 Calibrate Camera in Right Mirror 2

6.5 Head Up Display

Head up display is abbreviated as HUD. HUD is a transparent or miniature display for presenting vehicle dashboard data, such as speed and navigation, on the windshield in front of the driver, so that the driver can see them easily without looking down or turning his head, and can keep focused on the road ahead.

NOTE

Here we take Audi A7 2011 vehicle as an example for illustration, the calibration procedures may vary by vehicles. Please follow the specific instructions on your tablet.

6.5.1 Select a Situation That Needs Calibration

- Replaced Head UP Display (HUD) control module.
- Removed and installed windshield.
- No or incorrect basic setting/adaptation is stored in the DTC memory.

6.5.2 Required Calibration Tools

- ✓ Head-Up Display Calibration Board AUTEL-CSC0707/06.

6.5.3 Calibration Preparations

- Park the vehicle on a level surface;
- Apply the parking brake, the vehicle must not move during the calibration;

- Fold down the left and right sun visors, disengage them and move them to the side;
- Engage the Head Up Display (HUD) calibration board AUTEL-CSC0707/06 to the center support (1) and (2) of the sun visor.

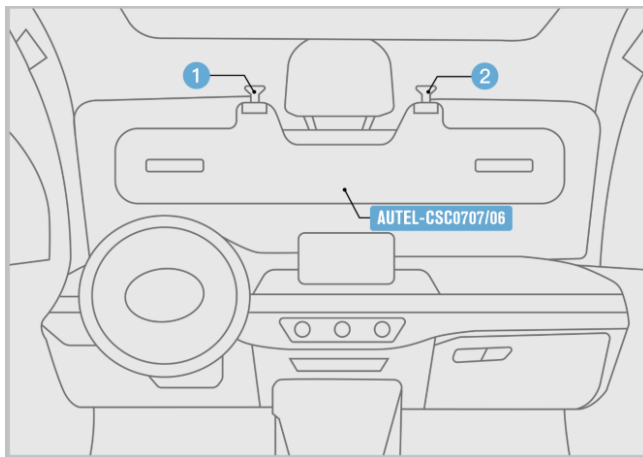



Figure 6-60 Place HUD Calibration Board

6.5.4 Start Calibration

Follow the illustration guide on the tablet, tap the  or  button to calibrate.

NOTE

The image below is for illustration only, the HUD image varies by vehicle, please refer to the actual.



Figure 6-61 HUD Image Correction

6.5.5 Head-up Display Image Correction

The head-up display images may be like the illustration below, like Trapezium, Cushion, Smile, Shear, Asymmetric shear horizontal, Asymmetric cushion horizontal, and Rotation. You can choose the most similar one to start calibration.

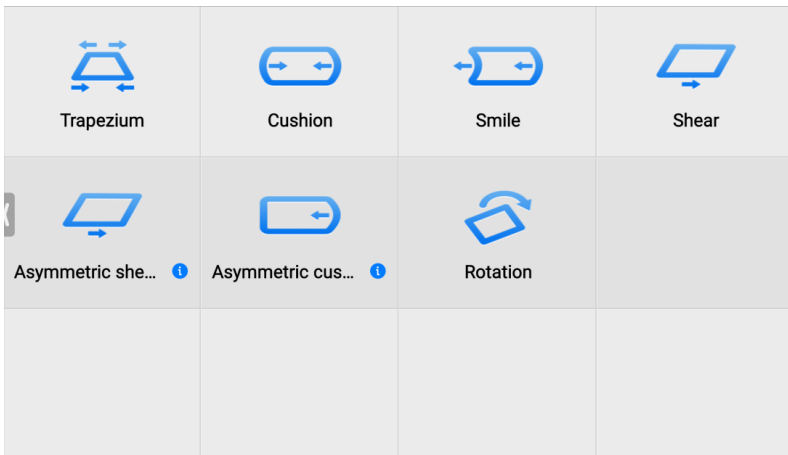

Figure 6-62 HUD Image Selection

6.6 Night Vision System

The night vision system with thermographic camera contributes to optimize the visibility during night driving, so that the drivers can gain more awareness on road condition, vehicle condition, and so on.

NOTE

- Here we take Audi A7 2011 vehicle as an example for illustration, the calibration procedures may vary by vehicles. Please follow the specific instructions on your tablet.
 - Ensure there is a minimum area of 1.2 m (3.94 ft) in front of the vehicle.
-

6.6.1 Select a Situation That Needs Calibration

- Repaired or replaced the Night Vision System (NVS) camera.
- Repaired or replaced the bumper or radiator grill.
- Adjusted the chassis.
- Changed the vehicle body height.
- Changed the position of NVS camera on the vehicle body.

6.6.2 Required Calibration Tools

- ✓ Calibration Frame AUTEL-CSC9000;
- ✓ NV Calibrator AUTEL-CSC0603/01;
- ✓ Wheel Clamp (Rim Clamp) AUTEL-CSC0500/19/LR;
- ✓ Wheel Clamp (Rim Clamp) AUTEL-CSC0500/19/RR;
- ✓ Target AUTEL-CSC0500/16/LR;
- ✓ Target AUTEL-CSC0500/16/RR;
- ✓ Distance Measuring Target AUTEL-CSC0500/08;
- ✓ 12 V Power Adapter.

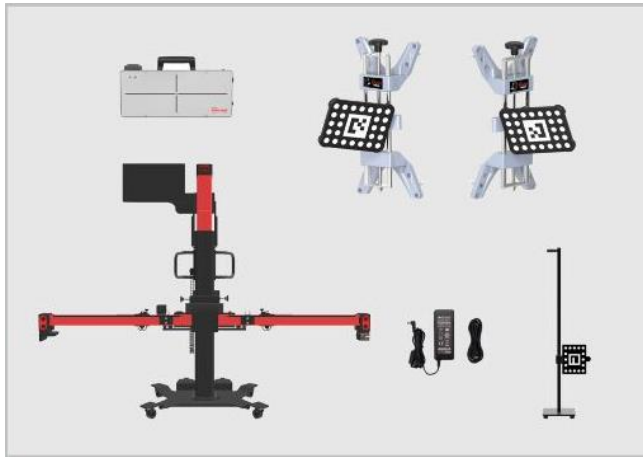

Figure 6-63 Required Calibration Tools

6.6.3 Calibration Preparations

- Center the steering wheel, and keep the front wheels of the vehicle in a straight ahead position (If necessary, perform the wheel alignment first);
- Ensure the vehicle's coolant and engine oil are at recommended levels and the gas tank is full. The vehicle should not be carrying any additional load (such as passengers or cargo);
- Attach the VCI to the vehicle and connect the diagnostic tool to the VCI (If the diagnostic tool and VCI are connected through diagnostic cable, guide the cable through window);
- Apply the parking brake, close all doors and turn off all external lighting;
- Adjust the tire pressure to the recommended value;
- Keep the vehicle in a cold state;
- If needed, connect the vehicle to a battery maintainer to prevent battery discharge.
- Check if the Night Vision System (NVS) camera is inside the holder and if the view is unobstructed. (The NVS camera is generally located near the grill or the front emblem of the vehicle)
- Check if the protective window of NVS camera is damaged. If yes, please replace it.

 **NOTE**

- Camera location may vary by vehicle.
- Tap **Video** to view a demonstration.
- Tap **OK** to complete auxiliary tool placement.
- Tap **Cancel** to exit Night Vision System (NVS) calibration.

6.6.4 Auxiliary Tool Positioning

➤ **To position the sliding plate**

1. Move the calibration frame to the level ground in front of the vehicle. If the pattern board has been installed onto the crossbar, remove it first.
2. Unfold both arms of the crossbar horizontally, and tighten the bolts (1) at the joints of the crossbar.
3. Hold the handles (2) on the sliding blocks, move the sliding blocks (3) on both sides to both ends and release the handle to fix the sliding blocks.
4. Hold the handle (4) on the sliding plate to move the sliding plate, so that the pointer on the sliding plate is aligned with the white mark line in position A, and then release the handle to fix the sliding plate.

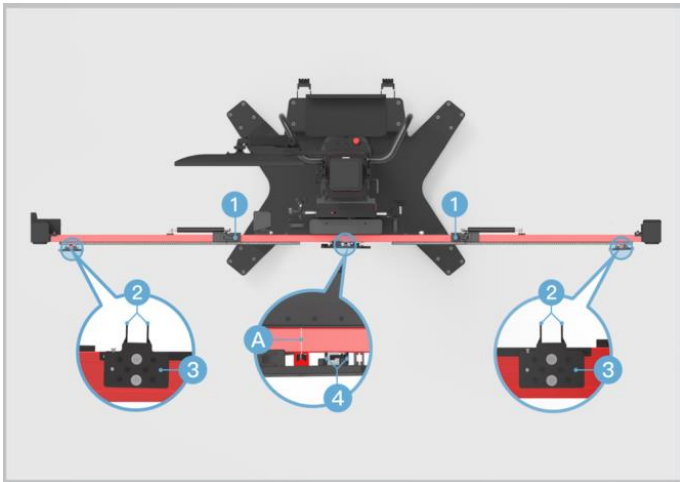

Figure 6-64 Position the Sliding Plate

➤ **To align with marked line and power on**

1. Loosen the handle (1) and rotate the fine-tuning bolt (2) until the position A is aligned with the red mark line. Tighten the handle (1) to secure the crossbar.

2. Rotate the fine turning bolt (3) until the position B is aligned with the red mark line.
3. Rotate the fine-tuning bolt (4) until the position C is aligned with the white mark line, and rotate the fine-tuning bolt (5) until the position D is aligned with the white mark line.
4. Connect the power supply and then turn on the power switch (6).

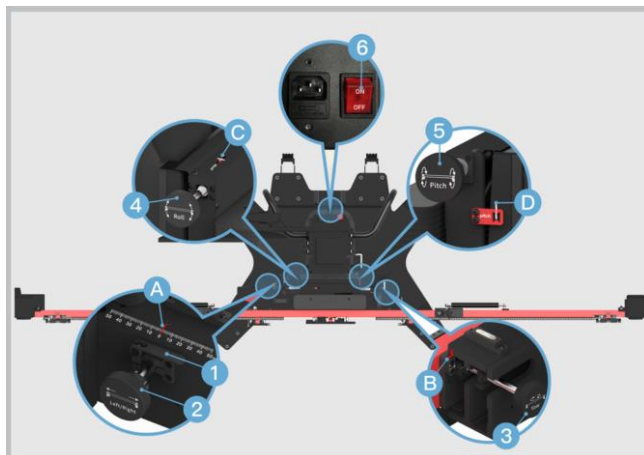

Figure 6-65 Align with Marked Lines

➤ **To center the laser at the front of the vehicle**

1. Place the calibration frame AUTEL-CSC9000 directly before the front center of the vehicle, and center the steering wheel.
2. Adjust the height of the crossbar by pressing **UP** and **DOWN** buttons on the back of the calibration frame, so that it is roughly at the same height as the center of the front wheel.
3. Hold the handle on the calibration frame and move the frame until the horizontal distances between the centers of front wheels and the back of the crossbar are roughly the same. Then turn on the laser (1) and the laser remains at the front center of the vehicle.

NOTE

Press the **EMERGENCY STOP** button to stop the lifting and lowering of the crossbar in emergency.

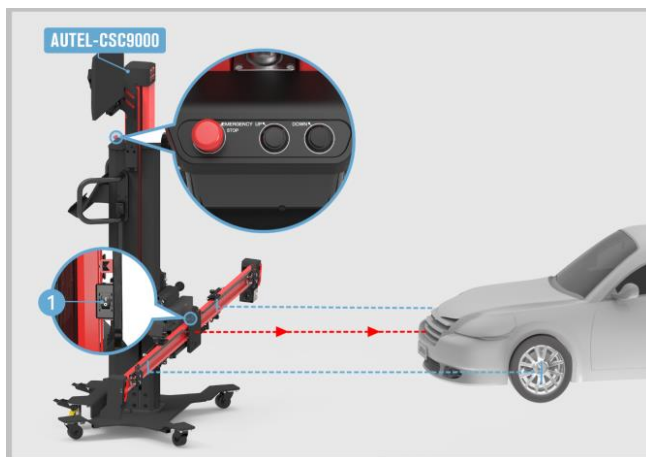

Figure 6-66 Center the Laser

➤ **To install the wheel clamps (rim clamps)**

1. Check the wheel clamp (rim clamp) AUTEL-CSC0500/19 and ensure its four pawls (2) are equal in length.
2. Attach the two wheel clamps (rim clamps) to the rear wheels respectively, and rotate the bolt (2) clockwise until the pawls (1) are tightly secured.

NOTE

Ensure the wheel clamps (rim clamps) are vertically installed on the rims, and the installation angle should be within -8° to 8° .

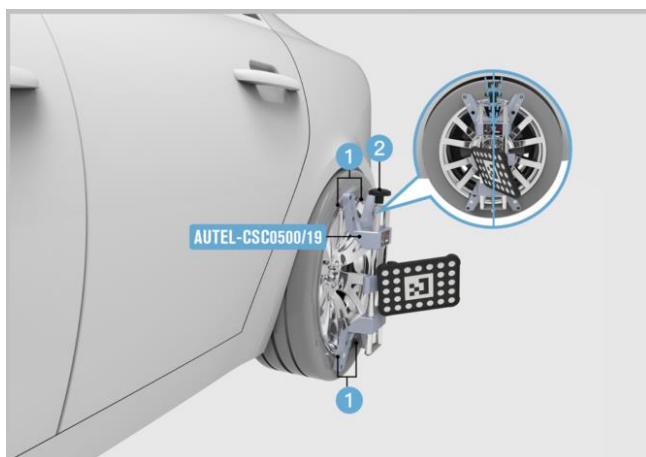

Figure 6-67 Install the Wheel Clamps (Rim Clamps)

➤ **To place and adjust the distance measuring target**

1. Place the distance measuring target AUTEL-CSC0500/08 in front of vehicle. Loosen the bolt (1) to adjust the height of the target so that it is roughly at the same height as the center of the license plate. Then tighten the bolt (1) to fix the target.
2. Move the distance measuring target to ensure the pointer (2) of the target touches the license plate and is aimed at the center of the license plate as precise as possible. Meanwhile, the white dotted side of the panel (3) faces the driving direction of the vehicle.

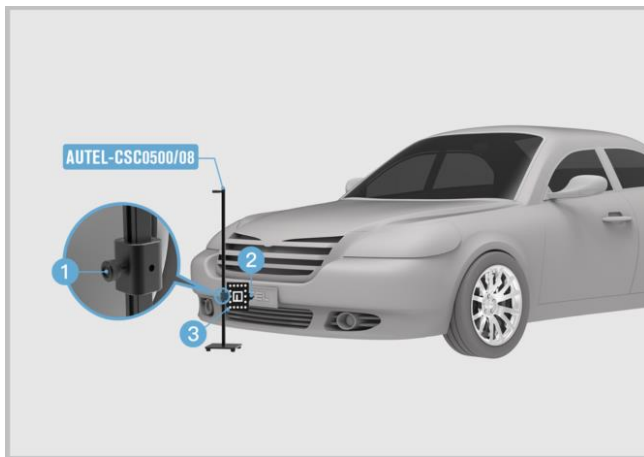

Figure 6-68 Adjust the Distance Measuring Target

🔧 **NOTE**

- During the automatic adjustment, ensure there are no obstructions which may interface with the movement of the crossbar.
- Once the position of distance measuring target has been obtained, a prompt of removing distance measuring target will appear on the screen.

➤ **To adjust and fix the calibration frame**

1. Positioning the ADAS calibration frame.
 - Step 1 (Rough adjustment): hold the handle (A) on the calibration frame and move the calibration frame until the 'Distance' value is displayed in green and ensure the calibration frame and the vehicle are roughly aligned;
 - Step 2 (Fine adjustment): rotate the fine-tuning bolt (D) until the 'Angle' value is displayed in green; loosen the handle (B) on the crossbar and rotate the fine-tuning bolt (C) according to the direction indicated by the

arrow until the 'Offset' value is displayed in green, then tighten the handle (B) to secure the crossbar;

- Step 3 (Completion): the position adjustment of the ADAS calibration frame is completed.

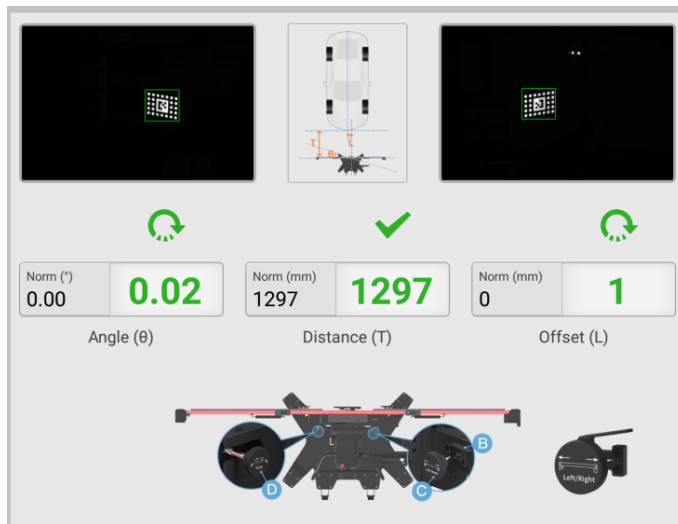

Figure 6-69 Adjust the Calibration Frame

2. After the placement of calibration frame, depress 2 brakes on the base to secure the calibration frame.
3. Turn off the sliding plate laser. Remove the wheel clamps (rim clamps) and targets.

➤ **To center the bubble level of NV calibrator**

1. Install the NV calibrator AUTEL-CSC0603/01 onto to the crossbar sliding plate.
2. Rotate the fine-tuning bolts (1) and (2) to ensure the bubble in the bubble level (3) of the NV calibrator is centered.



Figure 6-70 Center the Bubble Level of NV Calibrator

3. Plug the included power cord into the power port (1). Turn on the power switch (2) and the red LED (3) will light up. There are two ways to connect the power supply:
 - ✧ Use the 12 V power adapter that can match the calibration frame;
 - ✧ Use the 12 V power cord equipped with the calibration frame.

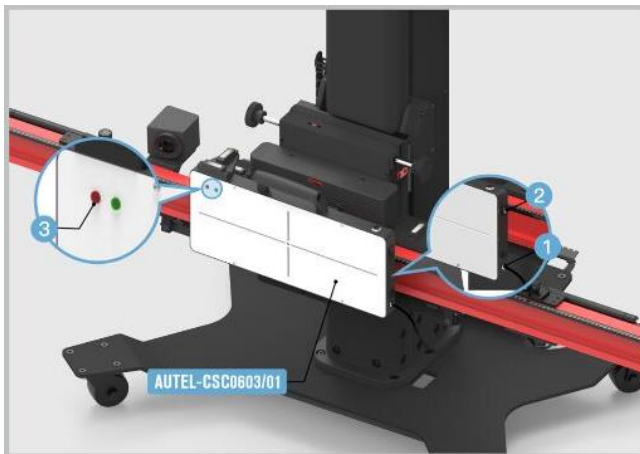

Figure 6-71 Connect Power

4. Turn on the laser (1).
5. Adjust the height of the crossbar and slide NV calibrator AUTEL-CSC0603/01 left or right to aim the laser beam (2) at the center of the NVS camera.

NOTE

If the bubble in the bubble level deviates from the center during the adjustment, rotate the bolt on the base so that the bubble in the bubble level is centered.

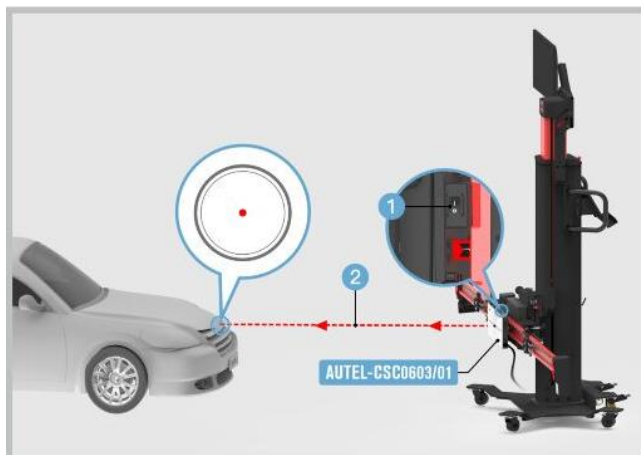

Figure 6-72 Center the Laser

6. Press the button (1) for 2 s until the buzzer beeps intermittently.
7. After about 20 s, the green LED (2) will light.

NOTE

- NV calibrator AUTEL-CSC0603/01 shuts off automatically after 30 mins. The green LED turns off and the buzzer beeps for 1 s. Press the button (1) for 2 s to restart.
 - To turn NV calibrator off, press and hold the button (1) for 2 s.
-

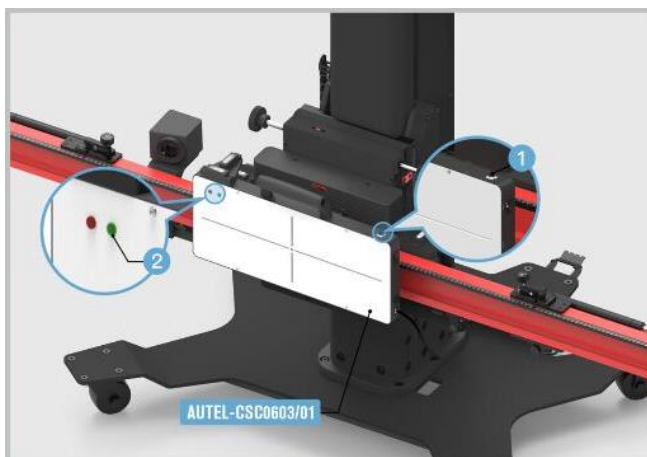

Figure 6-73 Activate NV Calibrator

NOTE

During adjustment the diagnostic tester automatically moves on if the roll angle setting is correct (for at least 1 second). Correct setting: -0.5° to 0.5° .

8. Continue the next procedures until the calibration is successful.

6.7 On-Board Camera

The on-board camera system is designed to warn the driver when the vehicle begins to move out of its lane on freeways and arterial roads. The system aims to minimize accidents caused by driver error, distraction and drowsiness.

NOTE

- Here we take Audi A7 2011 vehicle as an example for illustration, the calibration procedures may vary by vehicles. Please follow the specific instructions on your tablet.
 - Ensure there is a minimum area about 1.5 m (4.92 ft) between the center of the front wheel and the front of the vehicle.
-

6.7.1 Select a Situation That Needs Calibration

- Repaired or replaced the front video camera.
- Repaired or replaced the front windshield.
- Adjusted the chassis.
- Adjusted the vehicle body height.

- Relearned the vehicle height through vehicle height sensor.

6.7.2 Select the Vehicle Parking Position

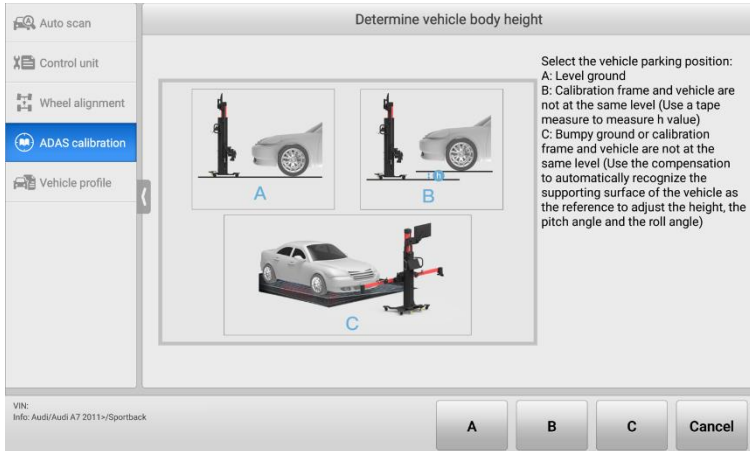

Figure 6-74 Select Vehicle Parking Position

- A: Level ground.
- B: Calibration frame and vehicle are not at the same level (use a tape measure to measure h value).

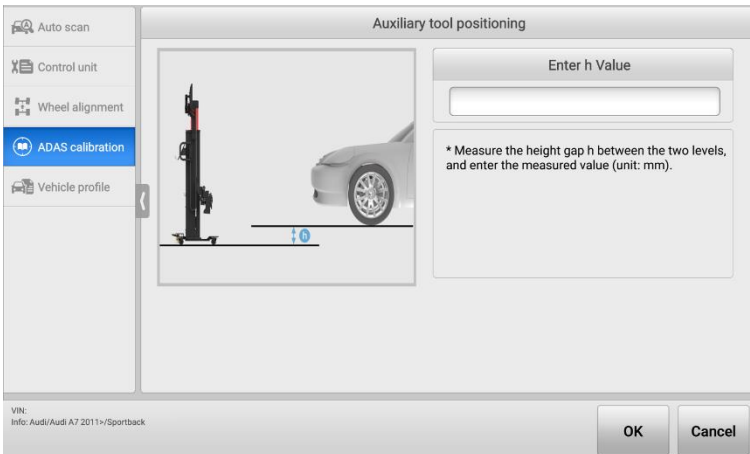

Figure 6-75 Measured Value h

- C: Bumpy ground or calibration frame and vehicle are not at the same level (use the compensation to automatically recognize the supporting surface of the vehicle as the reference to adjust the height, the pitch angle and the roll angle).

6.7.2.1 When Selecting A or B

1. Required Calibration Tools

- ✓ Calibration Frame AUTEL-CSC9000;
- ✓ Target Board AUTEL-CSC0601/01;
- ✓ Wheel Clamp (Rim Clamp) AUTEL-CSC0500/19/LR;
- ✓ Wheel Clamp (Rim Clamp) AUTEL-CSC0500/19/RR;
- ✓ Target AUTEL-CSC0500/16/LR;
- ✓ Target AUTEL-CSC0500/16/RR;
- ✓ Distance Measuring Target AUTEL-CSC0500/08.

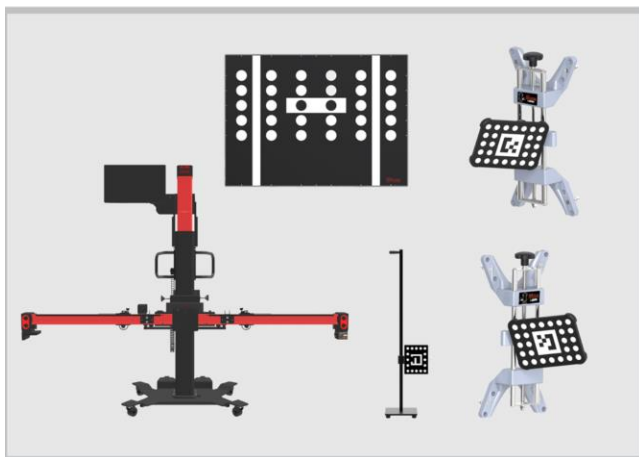

Figure 6-76 Required Calibration Tools (When Selecting A or B)

2. Calibration Preparations

- Park the vehicle on a level surface. Center the steering wheel, and keep the front wheels of the vehicle in a straight ahead position (If necessary, perform the wheel alignment first). Ensure there are enough space within 3 m (9.84 ft) or more in front of the vehicle;
- Bring the vehicle to a complete stop, confirm the rear thrust angle is aligned and turn the ignition off;

- Ensure the vehicle's coolant and engine oil are at recommended levels and the gas tank is full. The vehicle should not be carrying any additional load (such as passengers or cargo);
- Attach the VCI to the vehicle and connect the diagnostic tool to the VCI (If the diagnostic tool and VCI are connected through diagnostic cable, guide the cable through window);
- Close all doors and turn off all exterior lighting;
- Adjust the tire pressure to the specified value;
- If needed, connect the vehicle to a battery maintainer to prevent battery discharge;
- For vehicles with air suspension, activate the vehicle jack mode;
- Ensure the windshield and the camera lenses are clean, and there are no obstacles blocking the camera's view;
- Ensure the calibration area is well lit;
- Clean the dashboard, and free the dashboard from any foreign objects that can cause glare on the windshield.

 **NOTE**

- Ensure there is no reflection on the windshield (reflective objects can be covered with black cloth).
 - Tap **Video** to view a demonstration.
 - Tap **OK** to complete auxiliary tool placement.
 - Tap **Cancel** to exit the Front Camera calibration function.
-

3. **Auxiliary Tool Positioning**

➤ **To position the sliding plate**

1. Move the calibration frame to the level ground in front of the vehicle. If the pattern board has been installed onto the crossbar, remove it first.
2. Unfold the crossbar at both ends horizontally, and tighten the bolts (1) at the joints of the crossbar beams.
3. Hold the handles (2) on the sliding blocks, move the sliding blocks (3) on both sides to both ends and release the handle to fix the sliding blocks.
4. Hold the handle (4) on the sliding plate to move the sliding plate, so that the pointer on the sliding plate is aligned with the white mark line in position A, and then release the handle to fix the sliding plate.

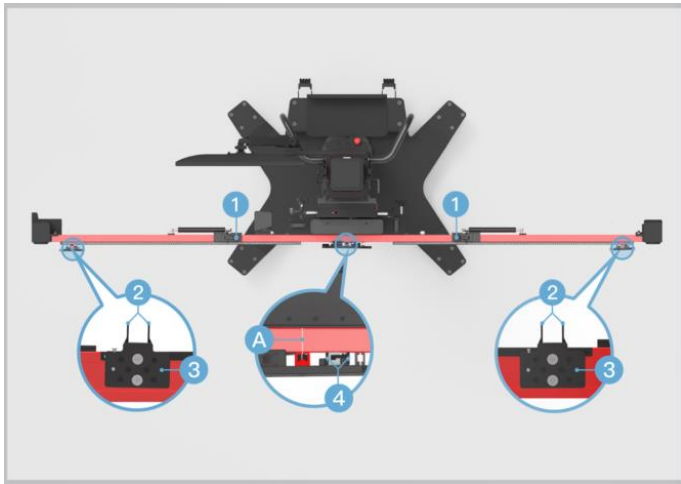

Figure 6-77 Position the Sliding Plate

➤ **To align with the marked lines and power on**

1. Loosen the handle (1) and rotate the fine-tuning bolt (2) until the position A is aligned with the red mark line. Tighten the handle (1) to secure the crossbar.
2. Rotate the fine turning bolt (3) until the position B is aligned with the red mark line.
3. Rotate the fine-tuning bolt (4) until the position C is aligned with the white mark line. And rotate the fine-tuning bolt (5) until the position D is aligned with the white mark line.
4. Connect the power supply and then tun on the power switch (6).

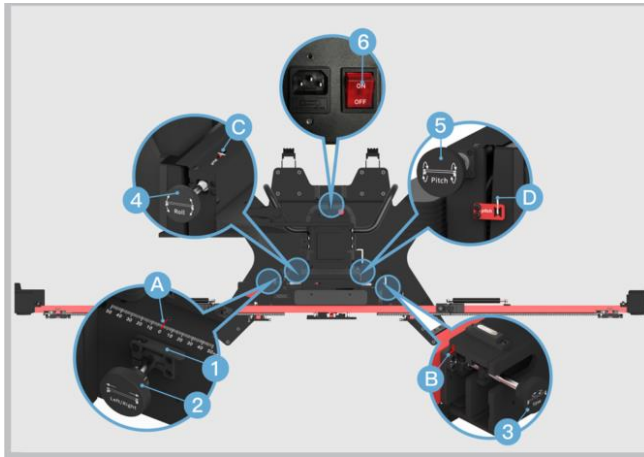

Figure 6-78 Align with Marked Lines

➤ **To center the laser at the front of the vehicle**

1. Place the calibration frame AUTEL-CSC9000 directly before the front center of the vehicle, and center the steering wheel.
2. Adjust the height of the crossbar by pressing **UP** and **DOWN** buttons on the back of the calibration frame, so that it is roughly at the same height as the center of the front wheel.
3. Hold the handle on the calibration frame and move the frame until the horizontal distances between the centers of front wheels and the back of the crossbar are roughly the same. Then turn on the laser (1) and the laser remains at the front center of the vehicle.

ⓘ **NOTE**

Press the **EMERGENCY STOP** button to stop the lifting and lowering of the crossbar in emergency.

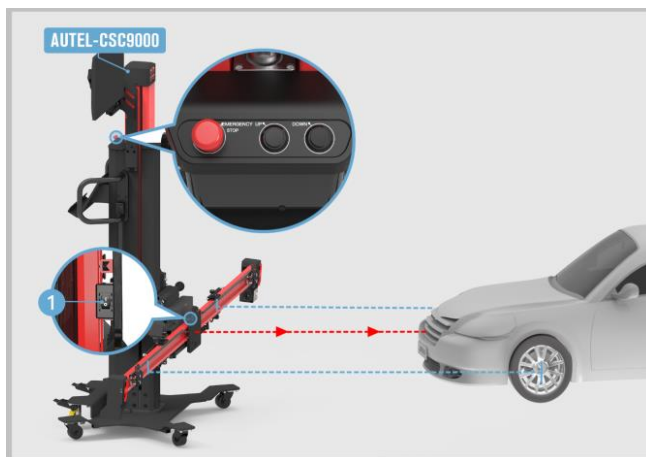

Figure 6-79 Center the Laser

➤ **To install the wheel clamps (rim clamps)**

1. Check the wheel clamp (rim clamp) AUTEL-CSC0500/19 and ensure its four pawls (2) are equal in length.
2. Attach the two wheel clamps (rim clamp) to the rear wheels respectively, and rotate the bolt (2) clockwise until the pawls (1) are tightly secured.

NOTE

Ensure the wheel clamps (rim clamps) are vertically installed on the rims, and the installation angle should be within -8° to 8° .

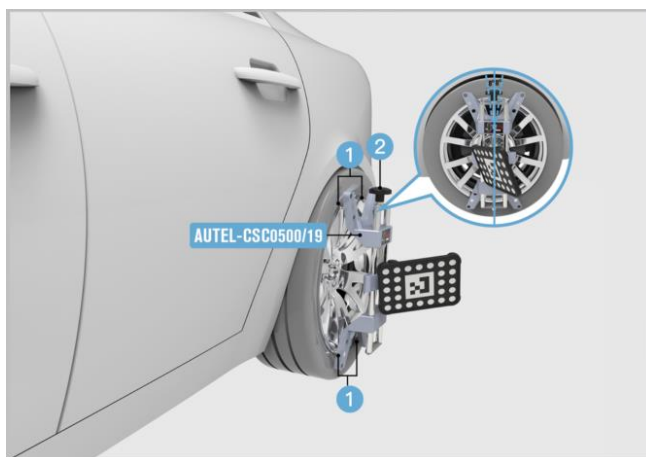

Figure 6-80 Install the Wheel Clamps (Rim Clamps)

➤ **To place the distance measuring target**

1. Place the distance measuring target AUTEL-CSC0500/08 in front of vehicle. Loosen the bolt (1) to adjust the height of the target so that it is roughly as the same height as the center of the license plate. Then tighten the bolt (1) to fix the target.
2. Move the distance measuring target to ensure the pointer (2) of the target touches the license plate and is aimed at the center of the license plate as precise as possible. Meanwhile, the white dotted side of the panel (3) faces the driving direction of the vehicle.

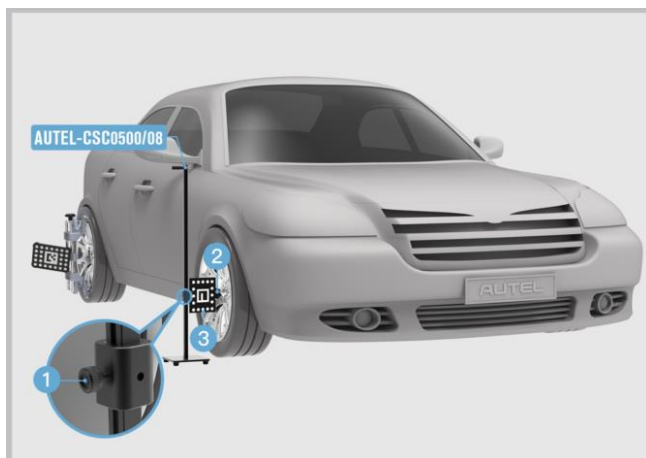

Figure 6-81 Adjust the Distance Measuring Target

NOTE

- During the automatic adjustment, ensure there are no obstructions which may interface with the movement of the crossbar.
- Once the position of the distance measuring target has been obtained, a prompt of removing distance measuring target will appear on the screen.

➤ **To adjust the calibration frame and pitch & roll angles**

1. Positioning the ADAS calibration frame.
 - Step 1 (Rough adjustment): hold the handle (A) on the calibration frame and move the calibration frame until the 'Distance' value is displayed in green and ensure the calibration frame and the vehicle are roughly aligned;
 - Step 2 (Fine adjustment): rotate the fine-tuning bolt (D) until the 'Angle' value is displayed in green; loosen the handle (B) on the crossbar and rotate the fine-tuning bolt (C) according to the direction indicated by the

arrow until the 'Offset' value is displayed in green, then tighten the handle (B) to secure the crossbar;

- Step 3 (Completion): the position adjustment of the ADAS calibration frame is completed.

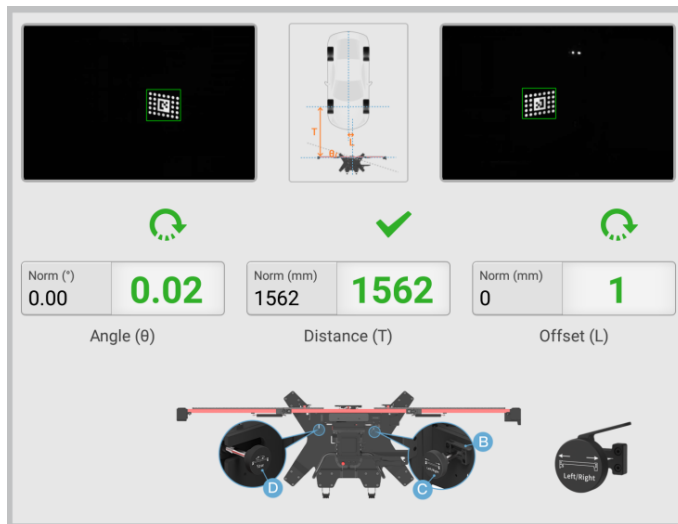

Figure 6-82 Adjust the Calibration Frame

2. After the placement of calibration frame, depress 2 brakes on the base to secure the calibration frame.
3. Turn off the sliding plate laser. Remove the wheel clamps (rim clamps) and targets.
4. When the pitch angle/roll angle of the calibration frame is abnormal, to guarantee the measurement accuracy, please rotate the fine-tuning bolts (A) and (B) respectively, so that the values of 'Pitch angle' and 'Roll angle' are displayed in green.

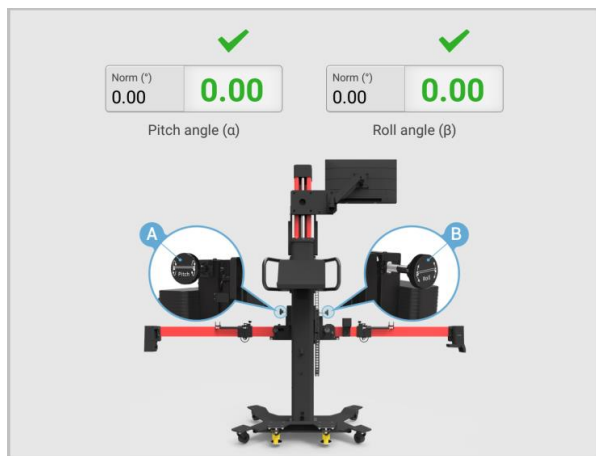

Figure 6-83 Adjust Pitch & Roll Angles

➤ **To attach and fix the target board**

1. Lower the target board holders (1) on both sides of the crossbar in calibration frame AUTEL-CSC9000, and then extend the target board holders to fix them.

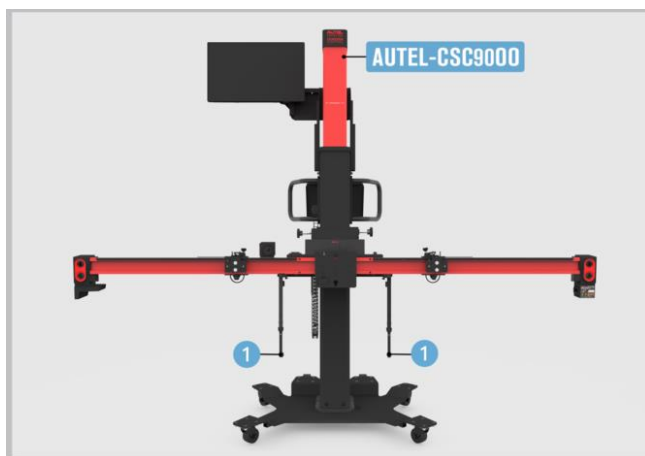

Figure 6-84 Extend Target Board Holder

2. Attach the target board AUTEL-CSC0601/01 to the calibration frame and fix the target board with two sliding blocks (1) on both sides of crossbar.

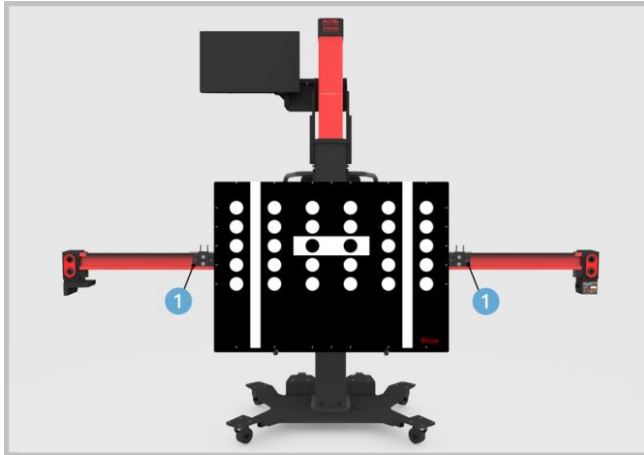

Figure 6-85 Fix the Target Board

➤ **To adjust the standard height**

Adjust the crossbeam height and wait for the crossbeam to reach the standard height position:

1. Tap **OK**, the calibration frame will automatically adjust to the standard height and enter the next screen.
2. Tap **Adjust Standard Height** to readjust the required height.

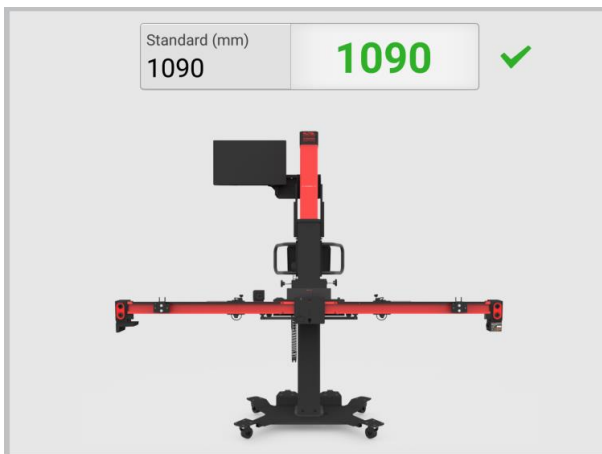

Figure 6-86 Adjust Standard Height

NOTE

During the automatic adjustment, ensure there are no obstructions which may interface with the movement of the crossbar.

➤ **To calibrate the front camera**

1. Choose wheel housing, and input the height of the Left Front wheel, the Right Front wheel, the Left Rear wheel and the Right Rear wheel. Tap **OK** after entering all the values. If the values are correct, tap **Yes** to proceed.

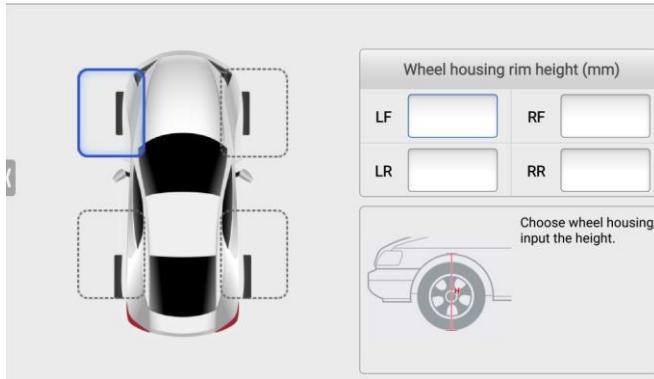

Figure 6-87 Input Wheel Housing Rim Height

2. Wait until the screen displays the 'Calibration successful, no malfunction', then tap **OK** to complete the calibration.

6.7.2.2 When Selecting C

1. **Required Calibration Tools**

- ✓ Calibration Frame AUTEL-CSC9000;
- ✓ Target Board AUTEL-CSC0601/01;
- ✓ Wheel Clamp (Rim Clamp) AUTEL-CSC0500/19/LF;
- ✓ Wheel Clamp (Rim Clamp) AUTEL-CSC0500/19/RF;
- ✓ Wheel Clamp (Rim Clamp) AUTEL-CSC0500/19/LR;
- ✓ Wheel Clamp (Rim Clamp) AUTEL-CSC0500/19/RR;
- ✓ Target AUTEL-CSC0500/16/LF;
- ✓ Target AUTEL-CSC0500/16/RF;
- ✓ Target AUTEL-CSC0500/16/LR;

- ✓ Target AUTEL-CSC0500/16/RR;
- ✓ Wheel Chock;
- ✓ Steering Wheel Holder Stand Tool.

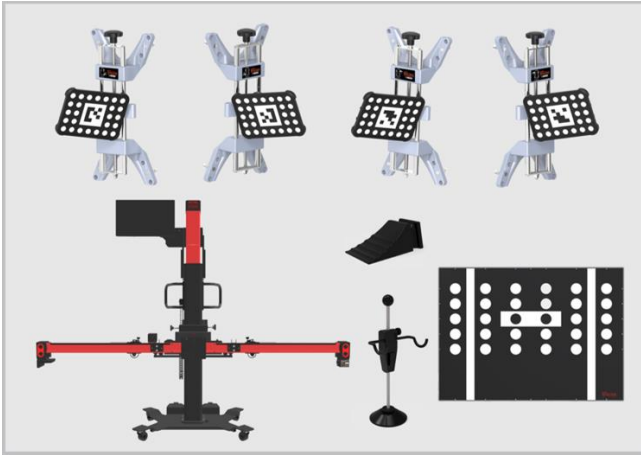



Figure 6-88 Required Calibration Tools

2. Calibration Preparations

- Park the vehicle on a level surface. Center the steering wheel, and keep the front wheels of the vehicle in a straight ahead position (If necessary, perform the wheel alignment first). Ensure there are enough space within 3 m (9.84 ft) or more in front of the vehicle;
- Bring the vehicle to a complete stop, confirm the rear thrust angle is aligned and turn the ignition off;
- Ensure the vehicle's coolant and engine oil are at recommended levels and the gas tank is full. The vehicle should not be carrying any additional load (such as passengers or cargo);
- Attach the VCI to the vehicle and connect the diagnostic tool to the VCI (If the diagnostic tool and VCI are connected through diagnostic cable, guide the cable through window);
- Close all doors and turn off all exterior lighting;
- Adjust the tire pressure to the specified value;
- If needed, connect the vehicle to a battery maintainer to prevent battery discharge;

- For vehicles with air suspension, activate the vehicle jack mode;
- Ensure the windshield and the camera lenses are clean, and there are no obstacles blocking the camera's view;
- Ensure the calibration area is well lit;
- Clean the dashboard, and free the dashboard from any foreign objects that can cause glare on the windshield.

 **NOTE**

- Ensure there is no reflection on the windshield (reflective objects can be covered with black cloth).
 - Tap **Video** to view a demonstration.
 - Tap **OK** to complete auxiliary tool placement.
 - Tap **Cancel** to exit the Front Camera calibration function.
-

3. **Vehicle Preparation**

- Park the vehicle on a level surface. Set the front wheels at the straight ahead position. Ensure a space of 1.5 m or more in front of the vehicle;
- Place the wheel chocks before and after the left rear or right rear wheel to prevent movement;
- Center the steering wheel and install the steering wheel holder stand tool. Release the parking brake and place the transmission in neutral;
- Keep the vehicle unladen. Ensure that the coolant and engine oil are at recommended levels and the fuel tank is full.
- Close all doors and turn off all external lighting;
- Adjust the tire pressure to the specified value;
- For vehicles equipped with air suspension, set the air suspension to the standard mode before performing the measurement (this adjustment process may vary on different vehicle models).

4. **Auxiliary Tool Positioning**

- **To position the sliding plate**
 1. Move the calibration frame to the level ground in front of the vehicle. If the pattern board has been installed onto the crossbar, remove it first.
 2. Unfold the crossbar at both ends horizontally, and tighten the bolts (1) at the joints of the crossbar beams.

3. Hold the handles (2) on the sliding blocks, move the sliding blocks (3) on both sides to both ends and release the handle to fix the sliding blocks.
4. Hold the handle (4) on the sliding plate to move the sliding plate, so that the pointer on the sliding plate is aligned with the white mark line in position A, and then release the handle to fix the sliding plate.

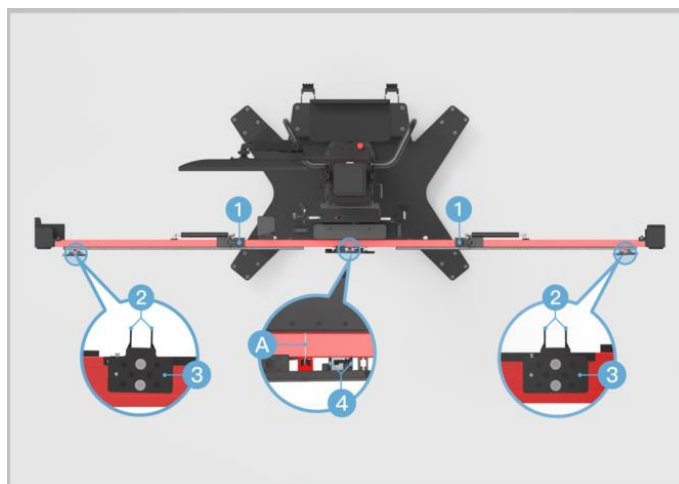

Figure 6-89 Position the Sliding Plate

➤ **To align with the marked lines and power on**

1. Loosen the handle (1) and rotate the fine-tuning bolt (2) until the position A is aligned with the red mark line. Tighten the handle (1) to secure the crossbar.
2. Rotate the fine turning bolt (3) until the position B is aligned with the red mark line.
3. Rotate the fine-tuning bolt (4) until the position C is aligned with the white mark line. And rotate the fine-tuning bolt (5) until the position D is aligned with the white mark line.
4. Connect the 220 V power, and then tun on the power switch (6).

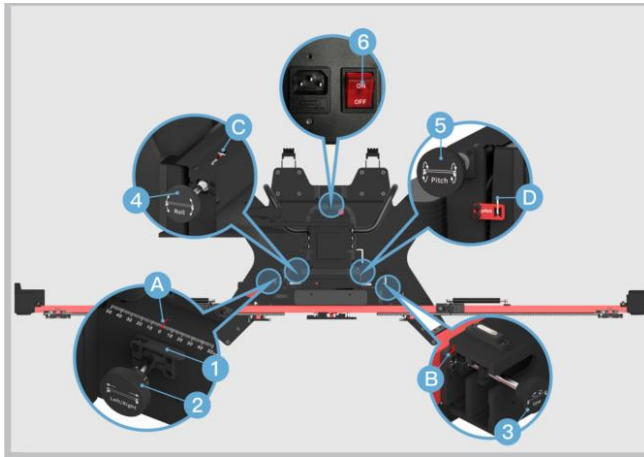

Figure 6-90 Align with Marked Lines

➤ **To center the laser at the front of the vehicle**

1. Place the calibration frame AUTEL-CSC9000 directly before the front center of the vehicle, and center the steering wheel.
2. Adjust the height of the crossbar by pressing **UP** and **DOWN** buttons on the back of the calibration frame, so that it is roughly at the same height as the center of the front wheel.
3. Hold the handle on the calibration frame and move the frame until the horizontal distances between the centers of front wheels and the back of the crossbar are roughly the same. Then turn on the laser (1) and the laser remains at the front center of the vehicle.

ⓘ **NOTE**

Press the **EMERGENCY STOP** button to stop the lifting and lowering of the crossbar in emergency.



Figure 6-91 Center the Laser

➤ **To install the wheel clamps (rim clamps)**

1. Check the wheel clamp (rim clamp) AUTEL-CSC0500/19 and ensure its four pawls (2) are equal in length.
2. Install four wheel clamp (rim clamp) pawls (1) to the rims and tighten the bolt (2) until the pawls (1) are tightly secured.

🔗 **NOTE**

- Ensure that the installation holes of four wheel clamp (rim clamp) pawls are in the same order from inside to outside.
 - Ensure the wheel clamps (rim clamps) are vertically installed on the rims, and the installation angle should be within -8° to 8° .
-

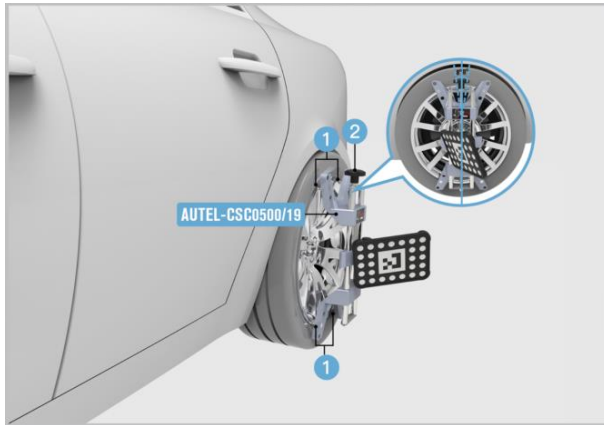

Figure 6-92 Install the Wheel Clamps (Rim Clamps)

➤ **To perform wheel rolling compensation**

1. According to the screen guides, move the wheel chock backward for about 30 cm, and then push the vehicle in the direction indicated by the arrow.

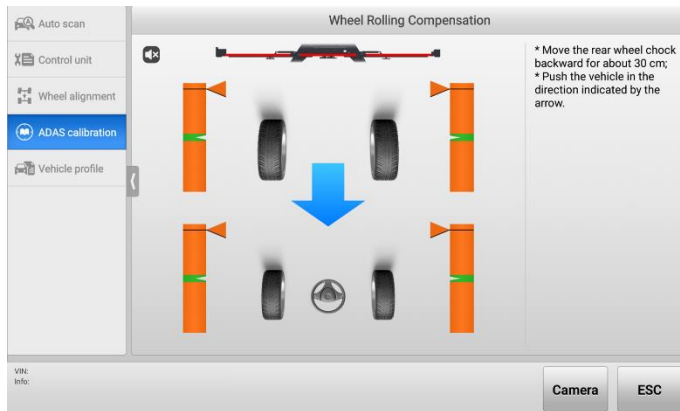

Figure 6-93 Wheel Rolling Compensation 1

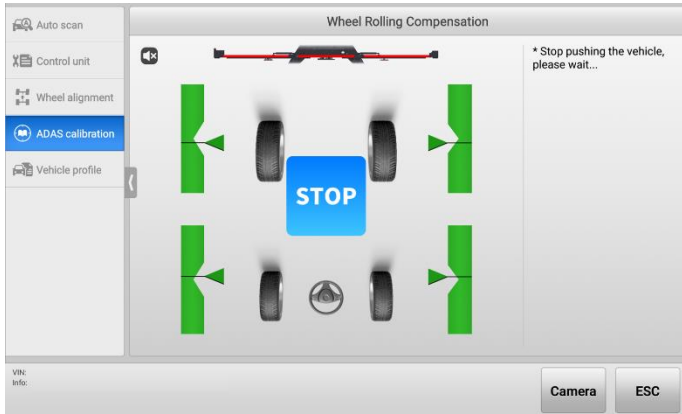

Figure 6-94 Wheel Rolling Compensation 2

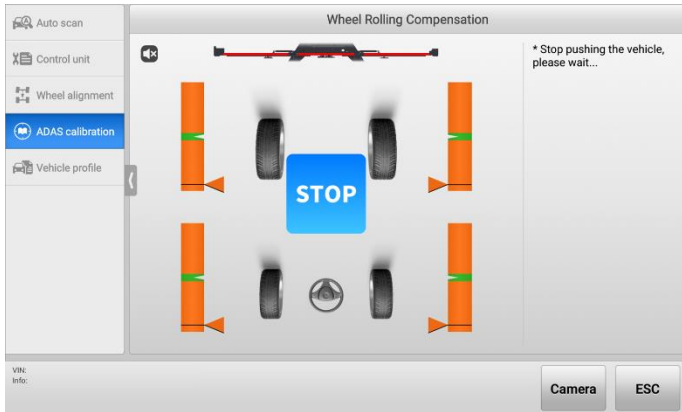

Figure 6-95 Wheel Rolling Compensation 3

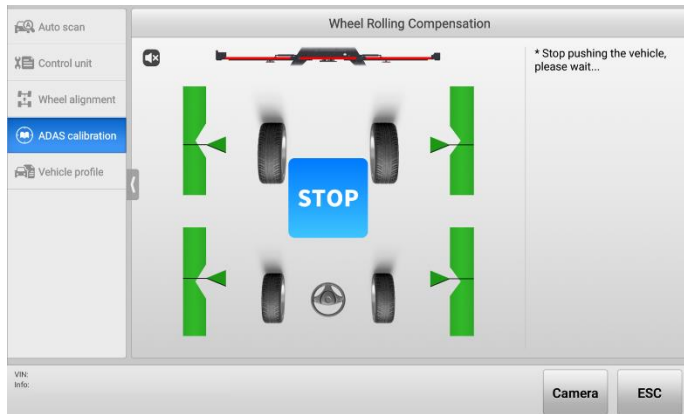

Figure 6-96 Wheel Rolling Compensation 4

2. If the rolling compensation is completed, the tablet will enter the next screen automatically.

NOTE

During the automatic adjustment, ensure there are no obstructions which may interface with the movement of the crossbar.

➤ **To adjust and fix the calibration frame and pitch & roll angles**

1. Positioning the ADAS calibration frame.
 - Step 1 (Rough adjustment): hold the handle (A) on the calibration frame and move the calibration frame until the 'Distance' value is displayed in green and ensure the calibration frame and the vehicle are roughly aligned.
 - Step 2 (Fine adjustment): rotate the fine-tuning bolt (D) until the 'Angle' value is displayed in green; loosen the handle (B) on the crossbar and rotate the fine-tuning bolt (C) according to the direction indicated by the arrow until the 'Offset' value is displayed in green, then tighten the handle (B) to secure the crossbar.
 - Step 3 (Completion): the position adjustment of the ADAS calibration frame is completed.

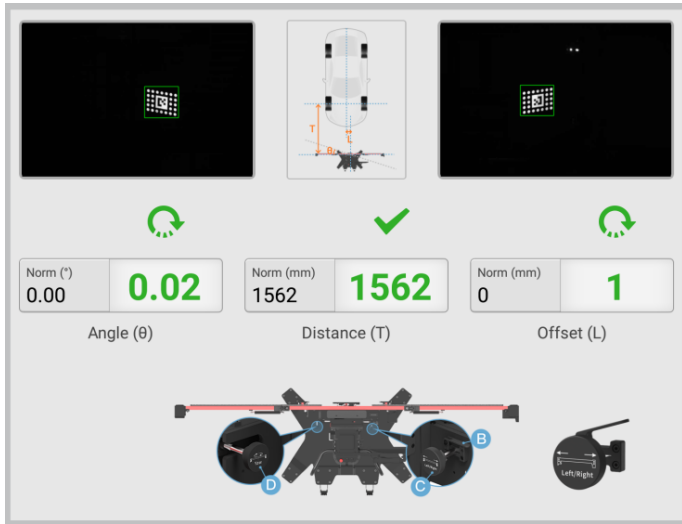

Figure 6-97 Position the Calibration Frame

2. After the placement of calibration frame, depress 2 brakes on the base to secure the calibration frame.
3. Turn off the sliding plate laser. Remove the wheel clamps (rim clamps) and targets.
4. When the pitch angle/roll angle of the calibration frame is abnormal, to guarantee the measurement accuracy, please rotate the fine-tuning bolts (A) and (B) respectively, so that the values of 'Pitch angle' and 'Roll angle' are displayed in green.

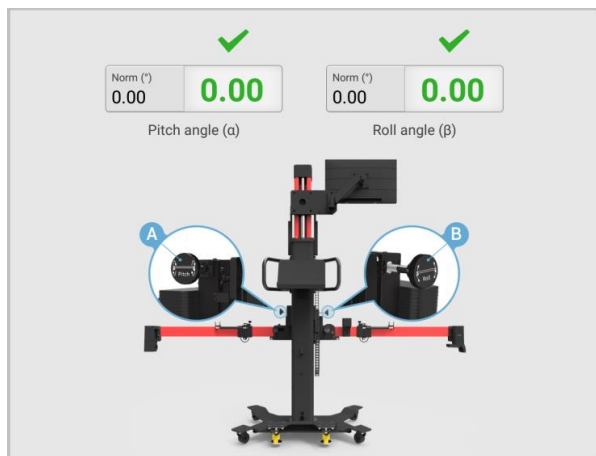

Figure 6-98 Adjust Pitch & Roll Angles

➤ **To attach and fix the target board**

1. Lower the target board holders (1) on both sides of the crossbar in calibration frame AUTEL-CSC9000, and then extend the target board holders to fix them.

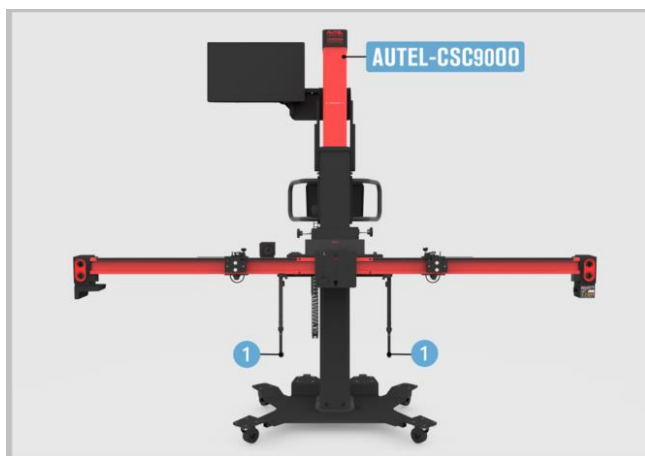

Figure 6-99 Extend Target Board Holder

2. Attach the target board AUTEL-CSC0601/01 to the calibration frame and fix the target board with two sliding blocks (1) on both sides of crossbar.

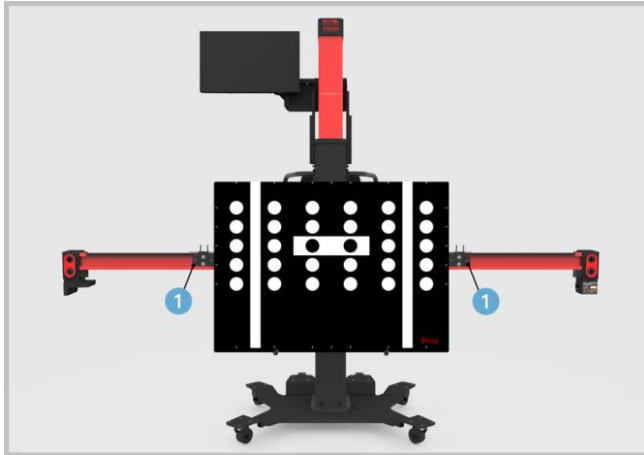

Figure 6-100 Fix the Target Board

➤ **To adjust the standard height**

1. Adjust the crossbar height and wait for the crossbar to reach the standard height position:
2. Tap **OK**, the calibration frame will automatically adjust to the standard height and enter the next screen.
3. Tap **Adjust Standard Height** to readjust the required height.

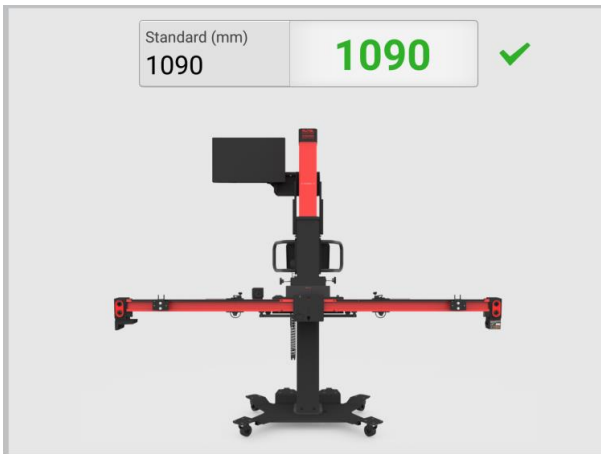

Figure 6-101 Adjust Standard Height

NOTE

During the automatic adjustment, ensure there are no obstructions which may interface with the movement of the crossbar.

➤ **To calibrate the front camera**

1. Choose wheel housing, and input the height of the Left Front wheel, the Right Front wheel, the Left Rear wheel and the Right Rear wheel. Tap **OK** after entering all the values. If the values are correct, tap **Yes** to proceed.

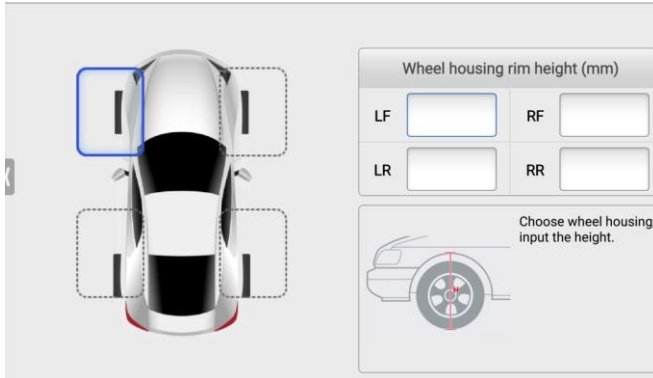

Figure 6-102 Input Wheel Housing Rim Height

2. Wait until the screen displays the 'Calibration successful, no malfunction', then tap **OK** to complete the calibration.

7 Maintenance and Service

7.1 Maintenance Instructions

7.1.1 Calibration Frame Maintenance

7.1.1.1 Camera Maintenance

Keep hands and tools away from the camera lens area.

DO NOT attempt to clean the camera lens with standard window cleaner and a cloth, or by blowing on them with shop air. If cleaning ever becomes necessary, it should be done with special optical cleaning fluid and/or canned air.

7.1.1.2 Footbrake Adjustment

When you feel that the footbrake is jacked up or not tight after you step on, you can adjust the height of the footbrake if necessary.

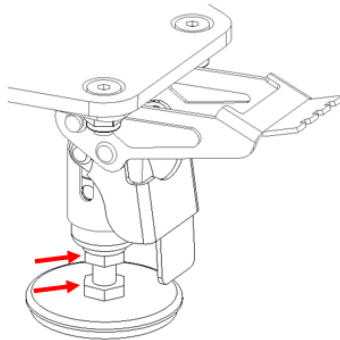

Adjustment method: use 2 monkey wrenches to snap into the two nuts on the bottom of the footbrake and loosen the upper nut in a clockwise direction, then rotate the foot cup to adjust to a suitable height. After that, rotate the upper nut in an anticlockwise direction to tighten the footbrake.

7.1.1.3 Guide Rail Maintenance

In order to make the calibration frame lift and fall smoothly, please add grease to the two guide rails every six months.

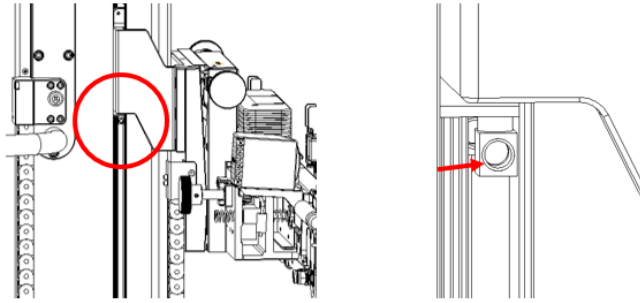

Maintenance method: locate the 2 oil filling ports (as the picture shows) from the gaps on both sides of the calibration frame and use a grease gun to fill them.

7.1.1.4 Chain Maintenance

To make the calibration frame lift and fall smoothly, apply anti-rust oil to both chains every six months.

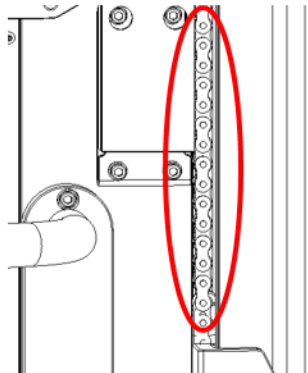

Maintenance method: locate the chain through the gaps on both sides of the calibration frame, and apply anti-rust oil along the surface of the chain.

7.1.2 Target Maintenance

DO NOT use hard objects to strike or scratch the surface of the target, which may cause the target to be unidentifiable. Notice a dirt build-up, oil or grease can also cause target identification problems.

In the target pattern display screen, the following red icon appears on the target pattern, which means the target may need cleaning.



Red icon: Target not found.

When cleaning the target, it is not recommended to use shop towels or rags as the fibers retain grease, which will be deposited back on the surface of the target in a thin film as wiping continues.

Use a mild cleaning solution and soft paper towels to wipe off the surface of targets.

DO NOT hose down or submerge the targets in water, or spray cleaner directly on the target. This could damage the optical components. When cleaning, wipe the entire target completely.

7.2 Service Procedures

This section introduces information for troubleshooting, technical support, repair service, and application for replacement or optional parts.

7.2.1 Self-inspection

1. After stepping on the footbrake, there is a jack up or the brake is not tight.
 - Check if the ground is level, if not, move to a level place;
 - If it cannot be moved indeed, refer to [Brake Pedal Depressor](#) to reinstall it.
2. The lifting mechanism of the calibration frame does not work.
 - Check if the power cord is well connected;
 - Check if the power switch of the calibration frame is on;
 - Check if the EMERGENCY STOP button is on;
 - Check if the arms of the crossbar are unfolded and locked;
 - Check if you have waited more than 5 seconds for the system turning on;
 - Check if the calibration frame reaches the lower limit position/upper limit position;
 - Check if the laser beam can reach the ground normally.
3. The lifting mechanism of the calibration frame is difficult to lift or fall.
 - Check whether the mounted ADAS tools, pattern boards, or other tools, are obstructing the lifting mechanism;
 - Check if charging cords or other cords are tangled.
 - Check if the rod for attaching pattern boards is fully expanded.
 - Check if the monitor is installed askew;
 - Check whether there are obstacles around the calibration frame.

4. The crossbar arms are unable or difficult to fold.
 - Check if the inner red column of the calibration frame is aligned with the warning sign;
 - Check whether the mounted ADAS tools, pattern boards, or other tools, are removed;
 - Check that the sliding plate slides away from the folding mechanism;
 - Check whether there are obstacles around the calibration frame.
5. The crossbar arms are unable or difficult to unfold.
 - Check if the inner red column of the calibration frame is aligned with the warning sign;
 - Check if the knob on the folding mechanism is rotated to its limit;
 - Check that the sliding plate slides away from the folding mechanism;
 - Check whether there are obstacles around the calibration frame.
6. The fine-tuning mechanism is hard to adjust.
 - Check that the lock block handle of the knob for adjusting crossbar position (left/right) is released;
 - Check whether all knobs are rotated to their limit.

7.2.2 After-sales Services

7.2.2.1 On-site Maintenance

1. The lifting mechanism of the calibration frame still does not work after self-inspection.
 - Enter factory mode by after-sales service personnel to check the status of each sensor and motor brake;
 - Remove the back cover to check whether the cables are loose, broken, etc.
2. The lifting mechanism of the calibration frame is still difficult to lift or fall after self-inspection.
 - Check whether the structure of the calibration frame is deformed by after-sales service personnel on site;
 - Enter the factory mode, check the status of each sensor and motor brake;
 - Remove the back cover to check whether the cables are loose, broken, etc.
3. The calibration frame lifts and falls with obvious abnormal noise and stuck.

- Enter factory mode by after-sales service personnel to check the status of each sensor and motor brake;
 - Remove the back cover to check whether the cables are loose, broken, etc.
4. When the calibration frame is powered on, it cannot stand still at any height or descend by itself.
 - Enter the factory mode by after-sales service personnel to check the state of the motor brake;
 - Remove the back cover to check whether the cables are loose, broken, etc.
 5. The key parts of the calibration frame are slightly loose.
 - On-site inspection by after-sales service personnel to determine whether it is normal, or whether it needs to be repaired or replaced.
 6. Other problems users cannot repair through self-inspection.

7.2.2.2 Return to Branch

1. The question still remains unsolved after after-sales service personnel on-site inspection.
 - The branch staff will contact the R&D department of the headquarters to check the calibration frame structure, hardware and software, etc., and provide solutions collaboratively.

7.2.2.3 Return to Headquarters

1. The question still remains unsettled after after-sales service personnel on-site inspection.
 - The R&D personnel of the headquarters will check the calibration frame structure, hardware and software, etc.
2. When the calibration frame is powered off, it cannot stand still at any height and will descend by itself.
 - The R&D personnel of the headquarters will check all parts of the calibration frame structure to troubleshoot.
3. Serious loosening or breakage of key components of the calibration frame.
 - The R&D personnel of the headquarters will check all parts of the calibration frame structure to troubleshoot.

7.2.3 Parts Replacement

- ◇ The parts users can replace by themselves
 1. Casters
 2. Footbrake
 3. The front cover of outer column
 4. The front cover of inner column
 5. External cords such as power cord, charging cord, the cords of monitor, etc.
 6. Large sliding plate
 7. Small sliding plate
 8. Pattern board holder
 9. The hooks of folding mechanism
 10. Chain
 11. Monitor mount
 12. Monitor
 13. The top cover of inner column
- ◇ The parts need to be replaced by after-sales service personnel
 1. Base
 2. Back cover
 3. Inside cords
 4. Internal hardware
 5. 12 V/24 V charging port
 6. Handle or handle holder
 7. Control buttons panel
 8. Chain
 9. Hinge of folding mechanism
 10. Spring of folding mechanism
 11. Camera (recalibration needed)

- ◇ The parts need to be returned to branch for replacement
 1. Electric pushrod or motor
 2. Column system
 3. Fine-tuning mechanism
 4. Crossbar
 5. Master control
 6. Crossbar lifting board
 7. Guide rail for inner column

7.2.4 Technical Support

If you have any questions or problems with the operation of the product, please contact us (see the following contact info) or your local distributor.

Autel China Headquarters

- **Phone:** +86 (0755) 8614-7779 (Monday-Friday, 9AM-6PM Beijing Time)
- **Email:** support@autel.com
- **Address:** Floor 2, Caihong Keji Building, 36 Hi-tech North Six Road, Songpingshan Community, Xili Sub-district, Nanshan District, Shenzhen City, China
- **Web:** www.autel.com

Autel North America

- **Phone:** 1-855-288-3587 (Monday-Friday, 9AM-6PM Eastern Time)
- **Email:** ussupport@autel.com
- **Address:** 36 Harbor Park Drive, Port Washington, New York, USA 11050
- **Web:** www.autel.com/us

Autel Europe

- **Phone:** +49(0)89 540299608 (Monday-Friday, 9AM-6PM Berlin Time)
- **Email:** support.eu@autel.com
- **Address:** Landsberger Str. 408, 81241 München, Germany
- **Web:** www.autel.eu

Autel APAC

Japan:

- **Phone:** +81-045-548-6282
- **Email:** support.jp@autel.com
- **Address:** 6th Floor, Ari-nadoribiru 3-7-7, Shinyokohama, Kohoku-ku, Yokohama-shi, Kanagawa-ken, 222-0033 Japan
- **Web:** www.autel.com/jp

Australia:

- **Email:** ausupport@autel.com
- **Address:** Unit 5, 25 Veronica Street, Capalaba

Autel IMEA

- **Phone:** +971 585 002709 (in UAE)
- **Email:** imea-support@autel.com
- **Address:** 906-17, Preatoni Tower (Cluster L), Jumeirah Lakes Tower, DMCC, Dubai, UAE
- **Web:** www.autel.com

Autel Latin America

Mexico:

- **Phone:** +52 33 1001 7880 (Spanish in Mexico)
- **Email:** latsupport@autel.com
- **Address:** Avenida Americas 1905, 6B, Colonia Aldrete, Guadalajara, Jalisco, Mexico

Brazil:

- **Email:** brsupport@autel.com
- **Address:** Avenida José de Souza Campos n° 900, sala 32 Nova Campinas Campinas – SP, Brazil
- **Web:** www.autel.com/br

7.2.5 Repair Service

If it becomes necessary to return your device for repair, please download the repair service form from www.autel.com, and fill it in. The following information must be included:

- Contact name
- Return address
- Telephone number
- Product name
- Complete description of the problem
- Proof-of-purchase for warranty repairs
- Preferred method of payment for non-warranty repairs

NOTE

For non-warranty repairs, payment can be made with Visa, Master Card, or with approved credit terms.

Send the device to your local agent, or to the below address:

Floor 2, Caihong Keji Building, 36 Hi-tech North Six Road, Songpingshan Community, Xili Sub-district, Nanshan District, Shenzhen City, China

7.2.6 Other Services

You can purchase the optional accessories directly from Autel's authorized tool suppliers, and/or your local distributor or agent.

Your purchase order should include the following information:

- Contact information
- Product or part name
- Item description
- Purchase quantity

8 Compliance Information

FCC Compliance

FCC ID: WQ8-IA900WA2021

This equipment has been tested and found to comply with the limits for a Class B digital device, pursuant to Part 15 of the FCC Rules. These limits are designed to provide reasonable protection against harmful interference in a residential installation. This equipment generates uses and can radiate radio frequency energy and, if not installed and used in accordance with the instructions, may cause harmful interference to radio communications. However, there is no guarantee that interference will not occur in a particular installation. If this equipment does cause harmful interference to radio or television reception, which can be determined by turning the equipment off and on, the user is encouraged to try to correct the interference by one or more of the following measures:

- Reorient or relocate the receiving antenna.
- Increase the separation between the equipment and receiver.
- Consult the dealer or an experienced radio/TV technician for help.

This device complies with Part 15 of the FCC rules. Operation is subject to the following two conditions:

1. This device may not cause harmful interference, and
2. This device must accept any interference received, including interference that may cause undesired operation.

Le présent appareil est conforme aux CNR d'Industrie Canada applicables aux appareils radio exempts de licence. L'exploitation est autorisée aux deux conditions suivantes:

1. l'appareil n' doit pas produire de brouillage, et
2. l'utilisateur de l'appareil doit accepter tout brouillage radioélectrique subi, même si le brouillage est susceptible d'en compromettre le fonctionnement.

WARNING

Changes or modifications not expressly approved by the party responsible for compliance could void the user's authority to operate the equipment.

 **NOTE**

This equipment has been tested and found to comply with the limits for a Class B digital device, pursuant to Part 15 of the FCC Rules. These limits are designed to provide reasonable protection against harmful interference in a residential installation.

This equipment generates uses and can radiate radio frequency energy and, if not installed and used in accordance with the instructions, may cause harmful interference to radio communications. However, there is no guarantee that interference will not occur in a particular installation. If this equipment does cause harmful interference to radio or television reception, which can be determined by turning the equipment off and on, the user is encouraged to try to correct the interference by one or more of the following measures:

- Reorient or relocate the receiving antenna.
- Increase the separation between the equipment and receiver.
- Connect the equipment into an outlet on a circuit different from that to which the receiver is connected.
- Consult the dealer or an experienced radio/TV technician for help.

FCC Radiation Exposure Statement

This equipment complies with FCC radiation exposure limits set forth for an uncontrolled environment. This equipment should be installed and operated with minimum distance 20cm between the radiator & your body.

CE Compliance

RED Directive 2014/53/EU

RoHS Compliance

This device is declared to be in compliance with the European RoHS Directive 2011/65/EU.

9 Warranty

9.1 Limited One Year Warranty

Autel Intelligent Technology Corp., Ltd. (the Company) warrants to the original retail purchaser of this device, that should this product or any part thereof during normal consumer usage and conditions, be proven defective in material or workmanship that results in product failure within one year period from the date of purchase, such defect(s) will be repaired, or replaced (with new or rebuilt parts) with Proof of Purchase, at the Company's option, without charge for parts or labor directly related to the defect(s).

NOTE

If the warranty period is inconsistent with local laws and regulations, please comply with the relevant local laws and regulations.

The Company shall not be liable for any incidental or consequential damages arising from the use, misuse, or mounting of the device. Some states do not allow limitation on how long an implied warranty lasts, so the above limitations may not apply to you.

This warranty does not apply to:

- a) Products subjected to abnormal use or conditions, accident, mishandling, neglect, unauthorized alteration, misuse, improper installation or repair or improper storage;
- b) Products whose mechanical serial number or electronic serial number has been removed, altered or defaced;
- c) Damage from exposure to excessive temperatures or extreme environmental conditions;
- d) Damage resulting from connection to, or use of any accessory or other product not approved or authorized by the Company;
- e) Defects in appearance, cosmetic, decorative or structural items such as framing and non-operative parts.
- f) Products damaged from external causes such as fire, dirt, sand, battery leakage, blown fuse, theft or improper usage of any electrical source.

IMPORTANT

All contents of the product may be deleted during the process of repair. You should create a back-up copy of any contents of your product before delivering the product for warranty service.

AUTEL[®]

Autel Intelligent Technology Corp., Ltd.

www.autel.com